



Prospect of Hadronic-Molecule / Cluster with Strangeness

- via the detailed study of the kaonic nucleus -

- 21 / 08 / 2024 -

M. Iwasaki / RIKEN

$\bar{K}N$ interaction study via Kaonic atom

Succeeded in Kaonic Hydrogen x-ray Measurement

Kp experiment at KEK in 1997:

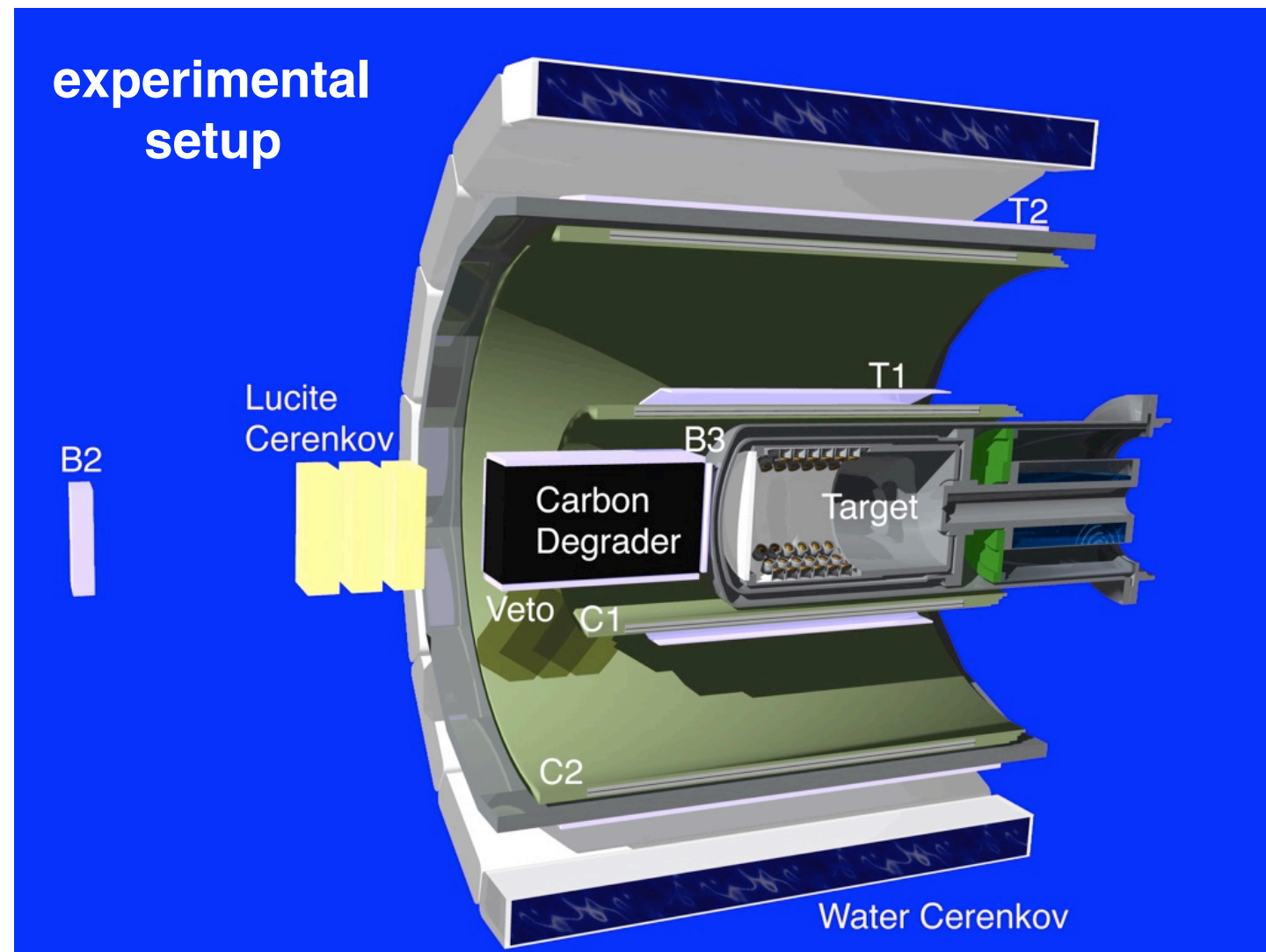
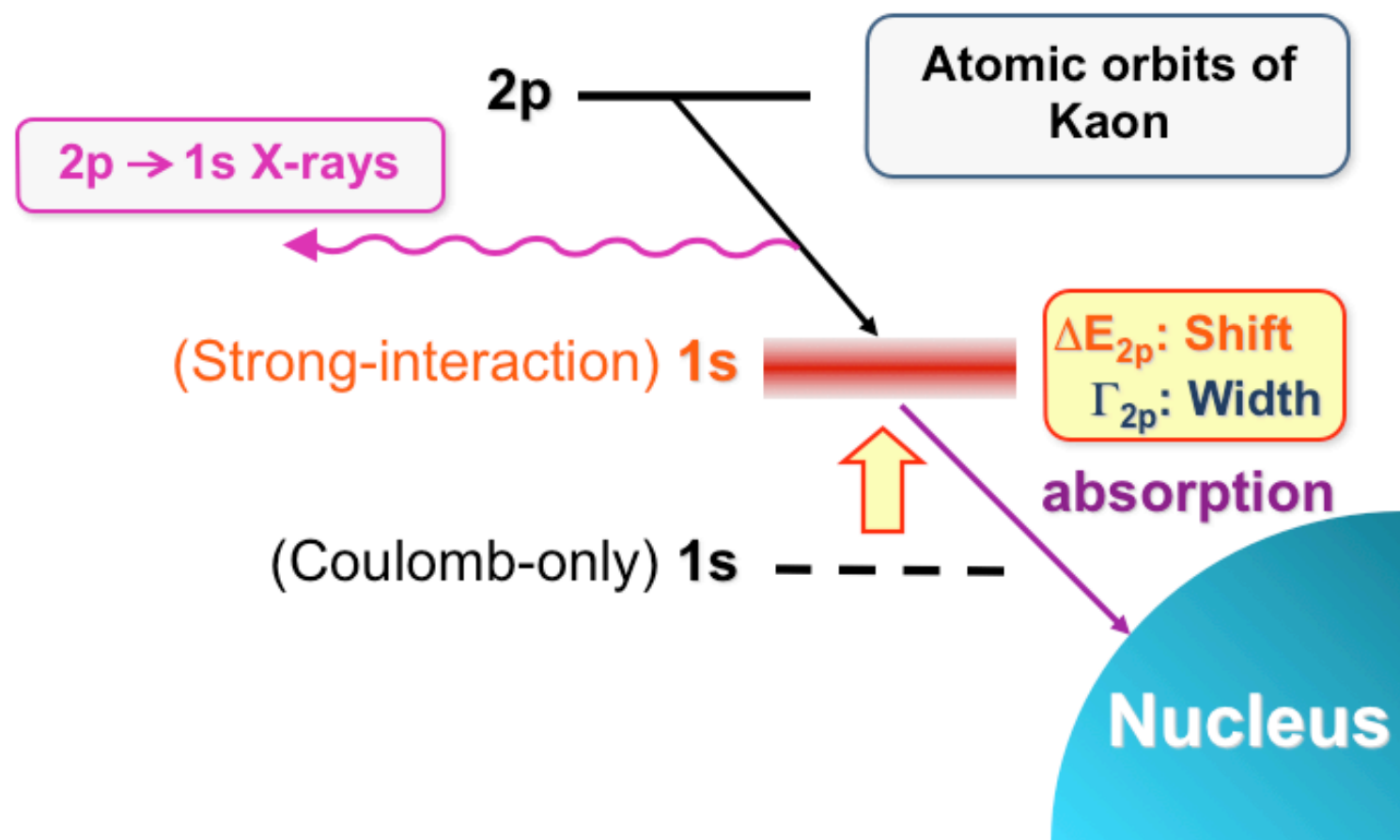

The European Physical Journal C

Volume 15 · Number 1-4 · 2000

THE $\Lambda(1405)$

Revised March 1998 by R.H. Dalitz, Oxford University

.....
 From the measurement of $2p - 1s$ x rays from kaonic-hydrogen, the energy-level shift ΔE and width Γ of its $1s$ state can give us two further constraints on the $(\bar{\Sigma}\pi, NK)$ system, at an energy roughly midway between those from the low-energy hydrogen bubble chamber studies and those from $qR(\Sigma\pi)$ observations below pK^- threshold. **IWASAKI 97** have reported the first convincing observation of this x ray, with a good initial estimate:

$$\Delta E - i\Gamma/2 = (-323 \pm 63 \pm 11) - i(204 \pm 104 \pm 50) \text{ eV. (2)}$$

the errors here encompass about half of the predictions made following various analyses and/or models for the in-flight K^-p and sub-threshold $qR(\Sigma\pi)$ data. Better measurements will be needed to discriminate between the analyses and predictions., perhaps from the **DAΦNE** storage ring at Frascati, information vital for our quantitative understanding of the $(\Sigma\pi, NK)$ system in this region.

KpX: obtained X-ray spectrum

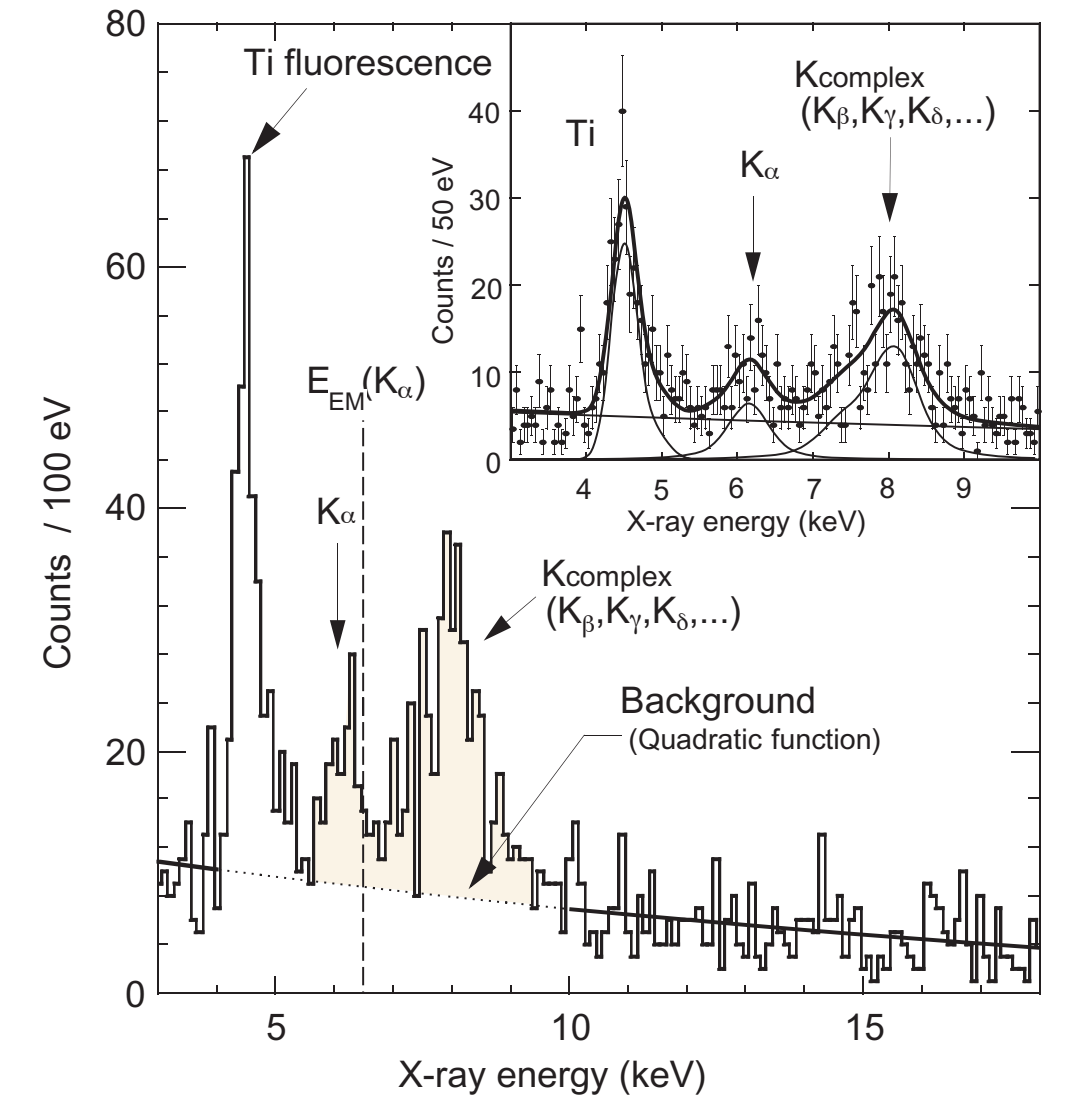

repulsive shift

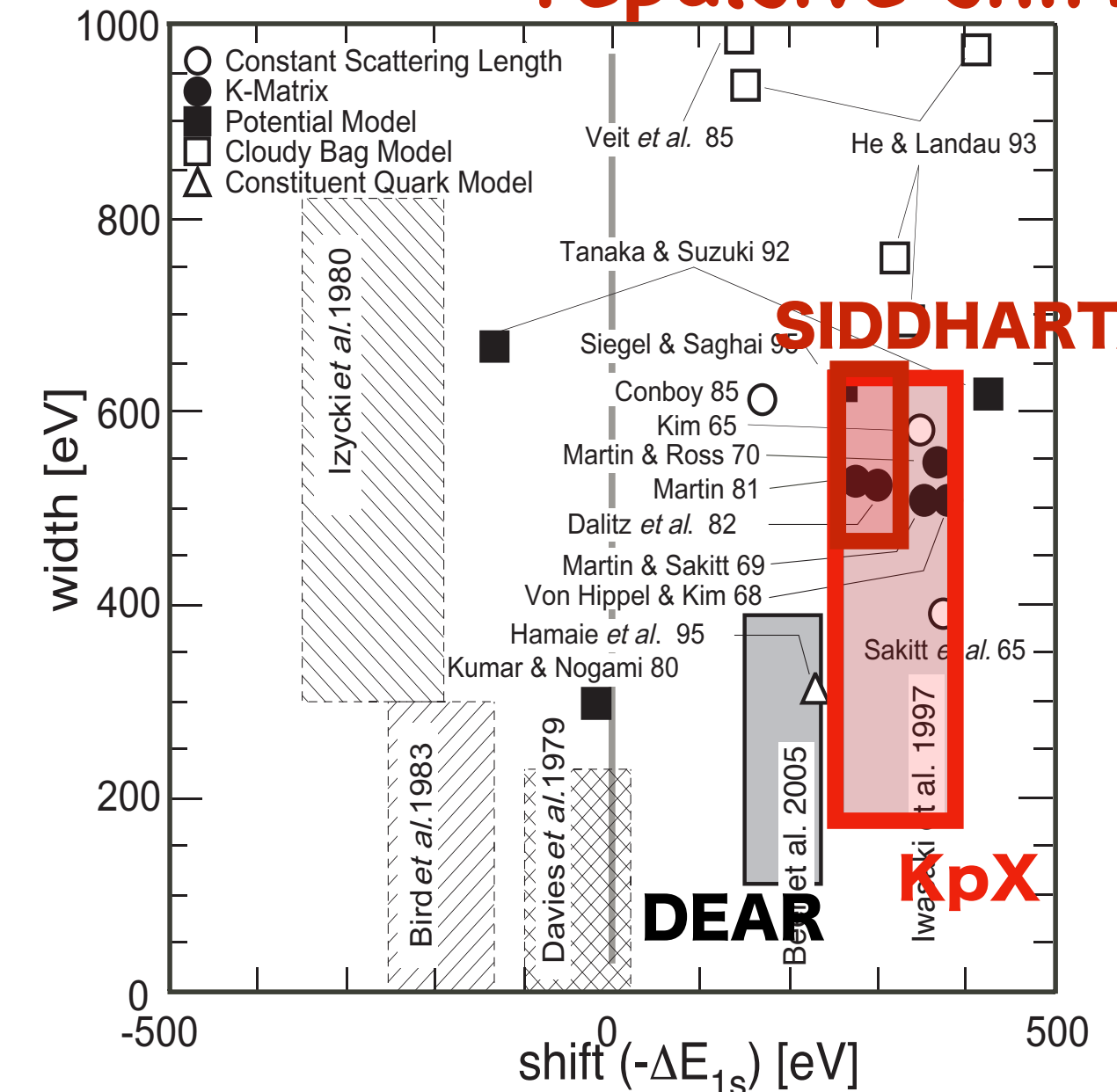

What's next in physics?

Observed Shift was **REPULSIVE!**

Is $\bar{K}N$ interaction repulsive?

Let's study how atomic level shifts depending on $\bar{K}N$ interaction.

Coulomb + $\bar{K}N$ interaction

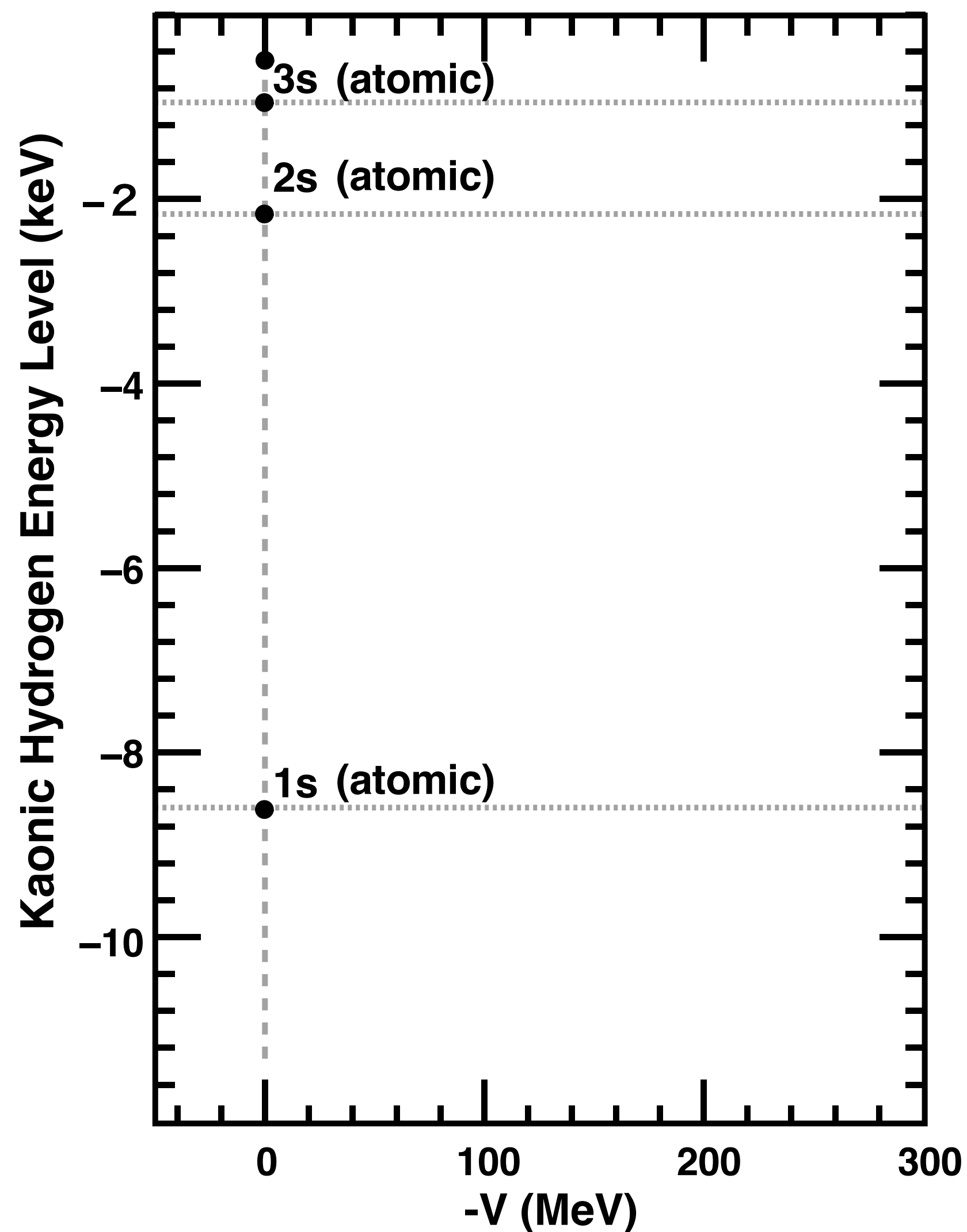

Without $\bar{K}N$ interaction
($V_{\bar{K}N} = 0, W_{\bar{K}N} = 0$), Coulomb potential
forms K^-p atomic levels.

Observed Shift was **REPULSIVE!**

Is $\bar{K}N$ interaction repulsive?

Let's study how atomic level shifts depending on $\bar{K}N$ interaction.

Coulomb + $\bar{K}N$ interaction

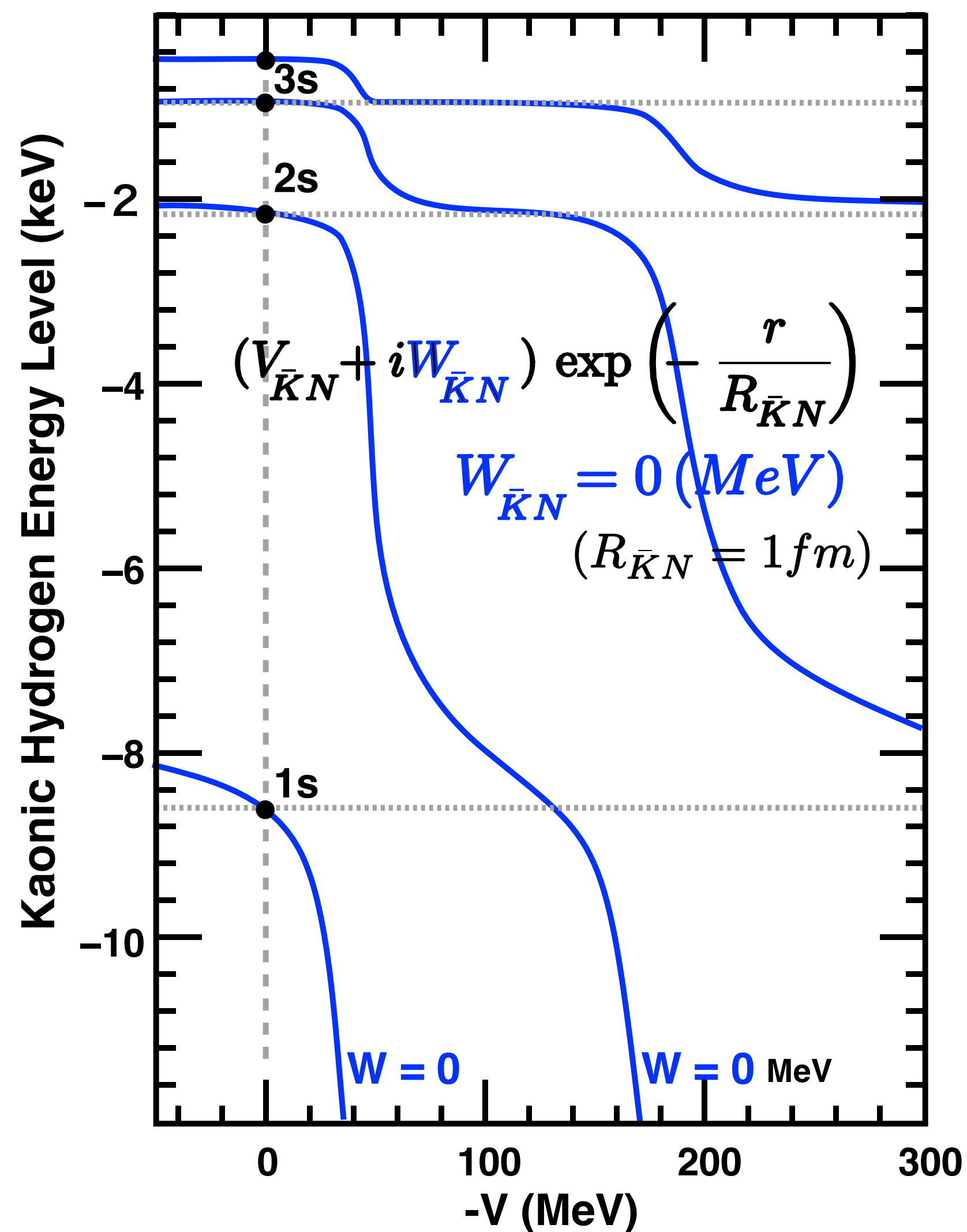

Without $\bar{K}N$ interaction

($V_{\bar{K}N} = 0, W_{\bar{K}N} = 0$), Coulomb potential forms K^-p atomic levels.

Each atomic level shifts downward as a function of $-V_{\bar{K}N}$ (at $W_{\bar{K}N} = 0$) in a step-like function, and atomic $1s$ change its nature to be a nuclear ground state.

Observed Shift was **REPULSIVE!**

Is $\bar{K}N$ interaction repulsive?

Let's study how atomic level shifts depending on $\bar{K}N$ interaction.

Coulomb + $\bar{K}N$ interaction

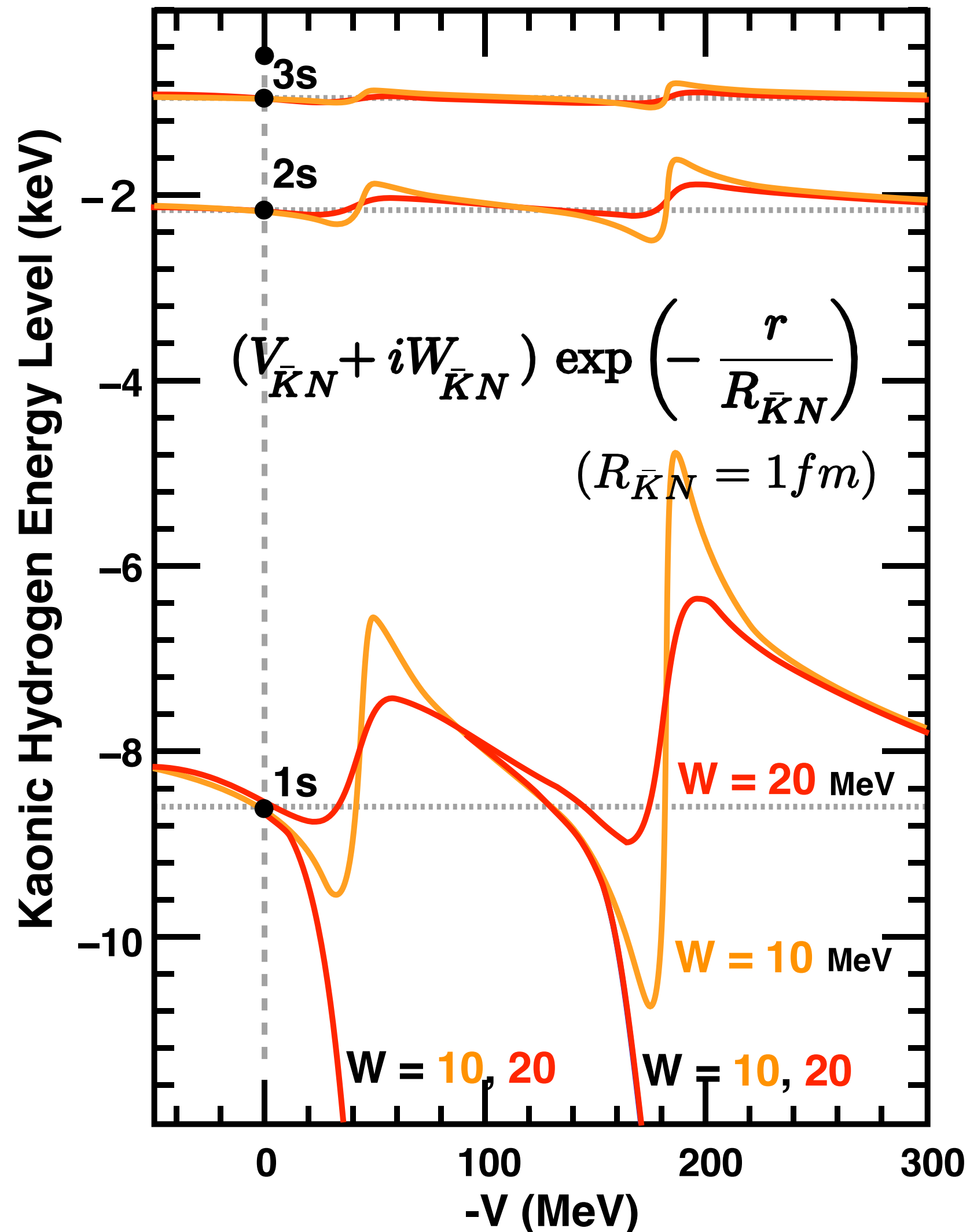

Without $\bar{K}N$ interaction

($V_{\bar{K}N} = 0, W_{\bar{K}N} = 0$), Coulomb potential forms K^-p atomic levels.

Each atomic level shifts downward as a function of $-V_{\bar{K}N}$ (at $W_{\bar{K}N} = 0$) in a step-like function, and atomic $1s$ change its nature to be a nuclear ground state.

When switching on the absorption part $W_{\bar{K}N}$, a level crossing happens and connects to another level.

As a result, a wiggling pattern appears in energy levels (red lines), and the nuclear bound state is branched and separated from the atomic ground state.

Observed Shift was **REPULSIVE!**

Is $\bar{K}N$ interaction repulsive?

Coulomb + $\bar{K}N$ interaction

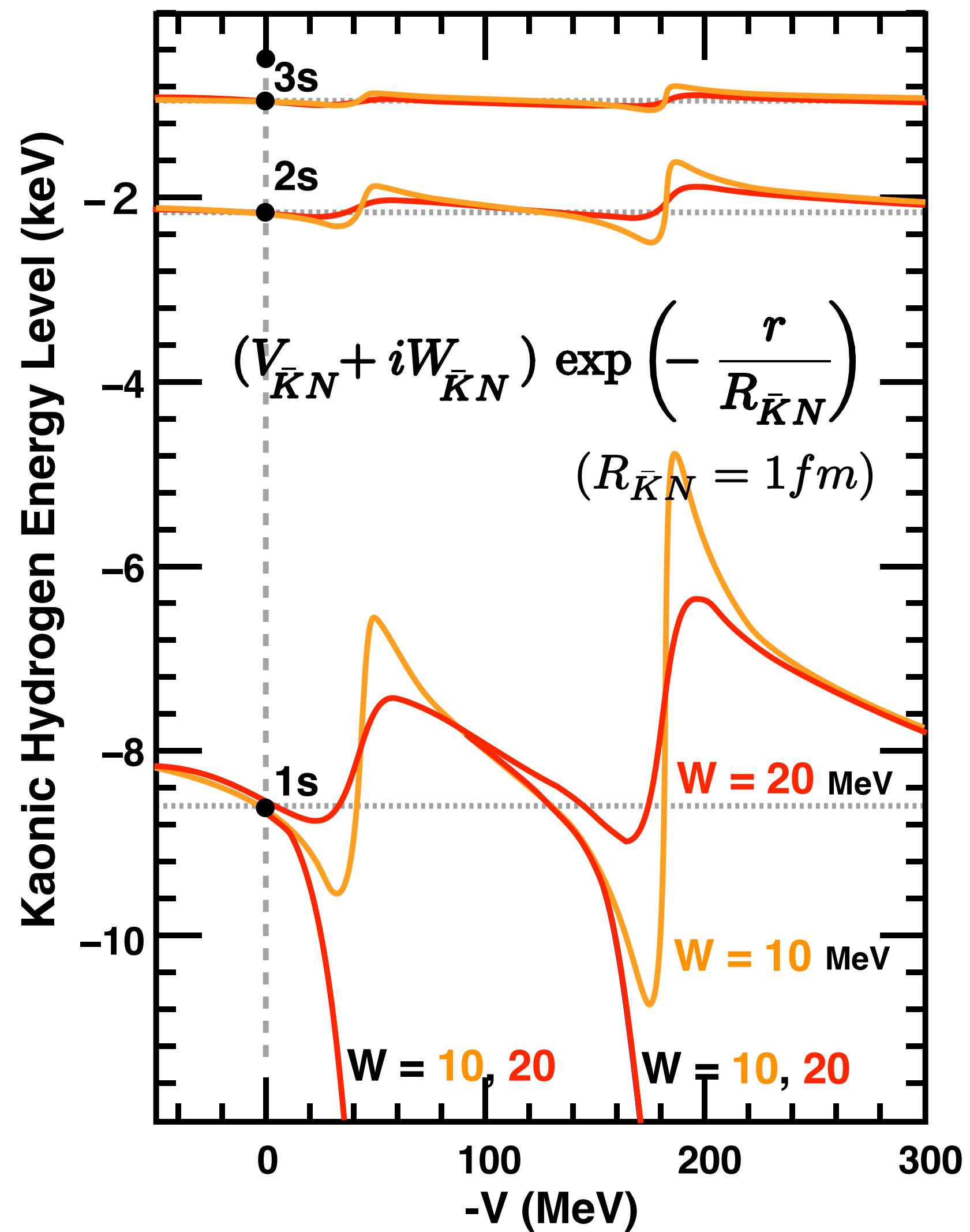

Observed Shift was **REPULSIVE!**

Is $\bar{K}N$ interaction repulsive?

Coulomb + $\bar{K}N$ interaction

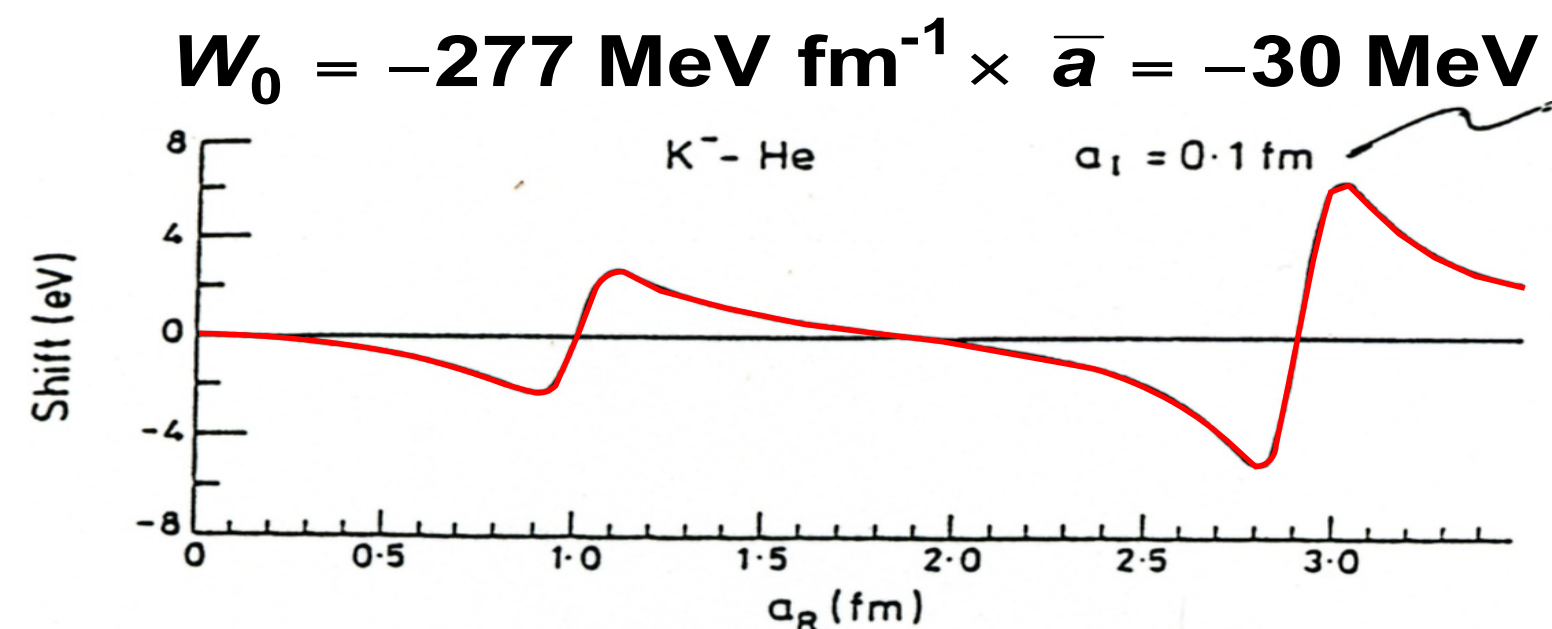
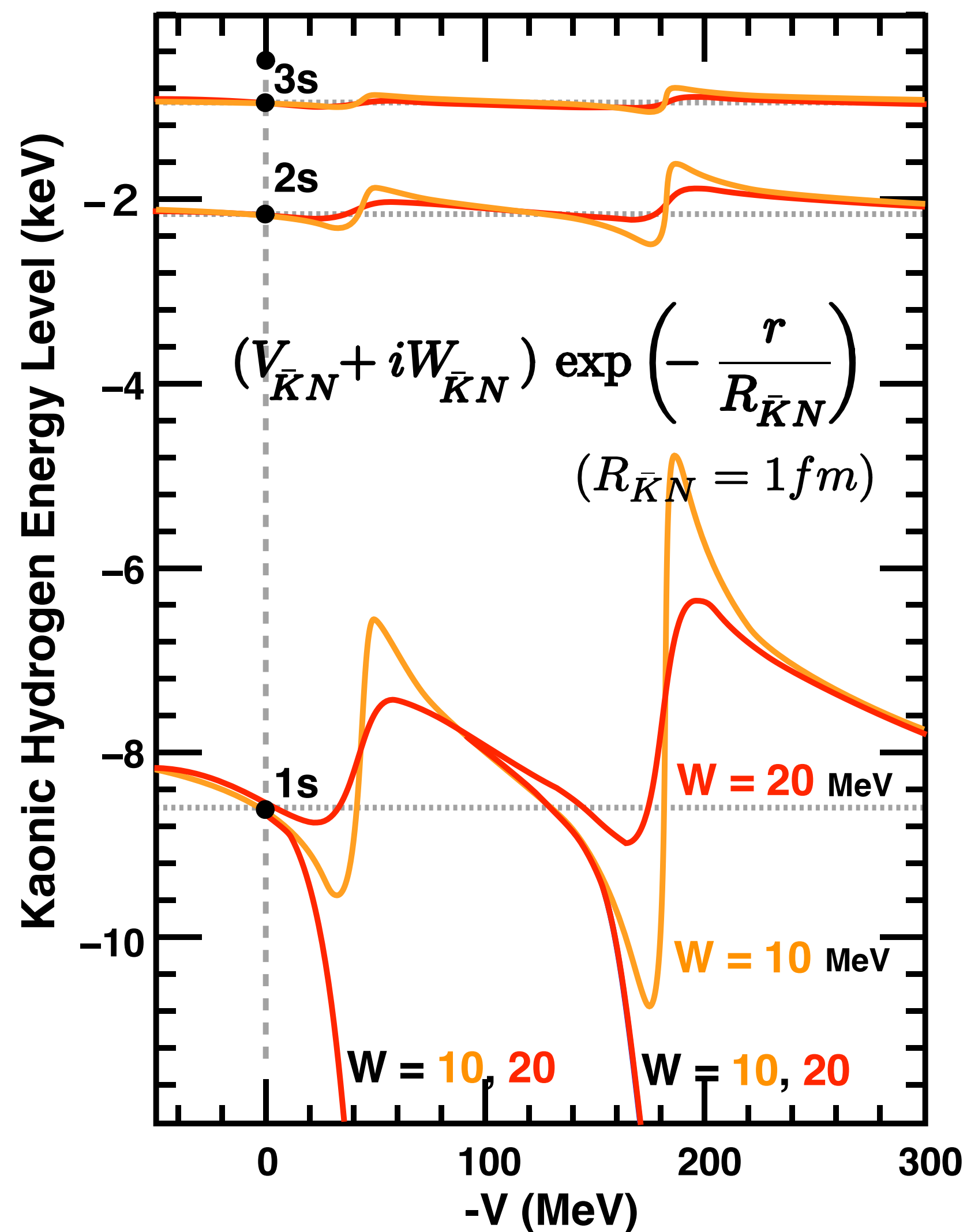

Theoretical calculations for realistic $\bar{K}N$ interaction

R. Seki, Phys. Rev. C5 (1972) 1196

S. Baird et al., Nucl. Phys. A392 (1983) 297

C.J. Batty, Nucl. Phys. A508 (1990) 89c

Observed Shift was **REPULSIVE!**

Is $\bar{K}N$ interaction repulsive?

Coulomb + $\bar{K}N$ interaction

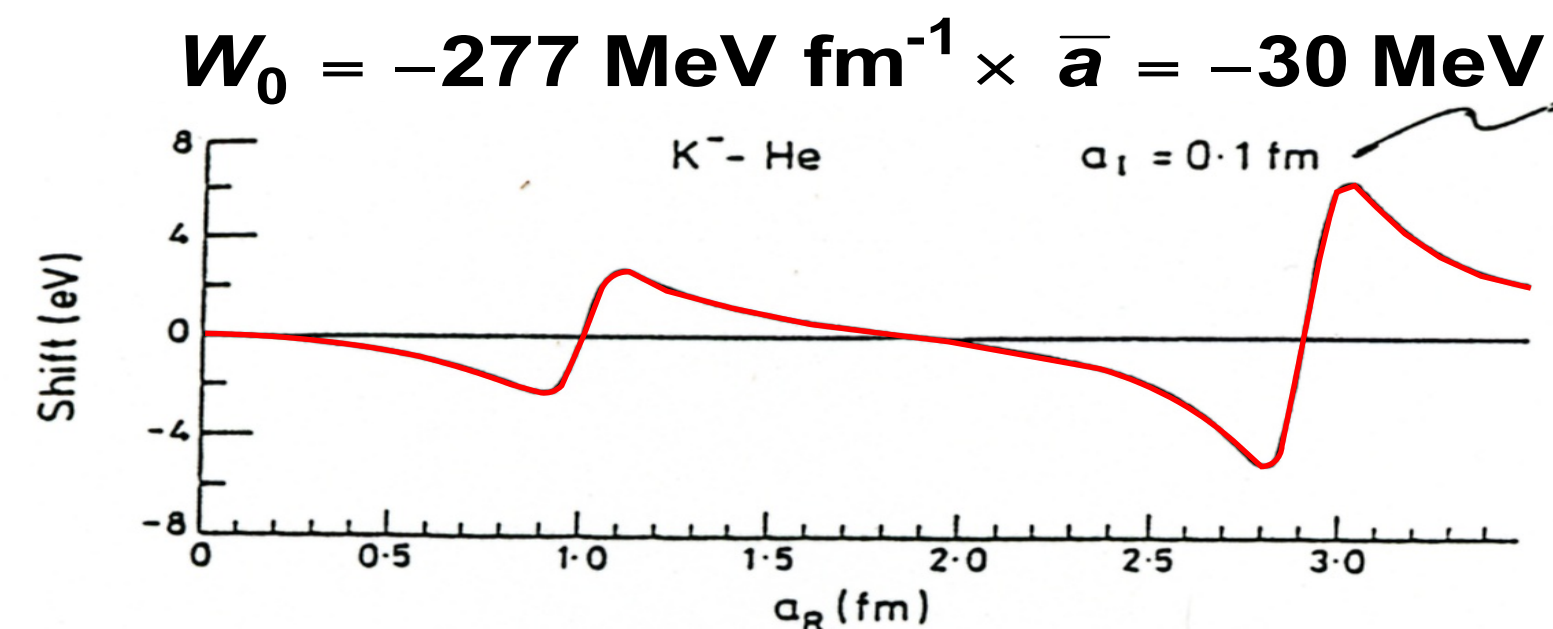
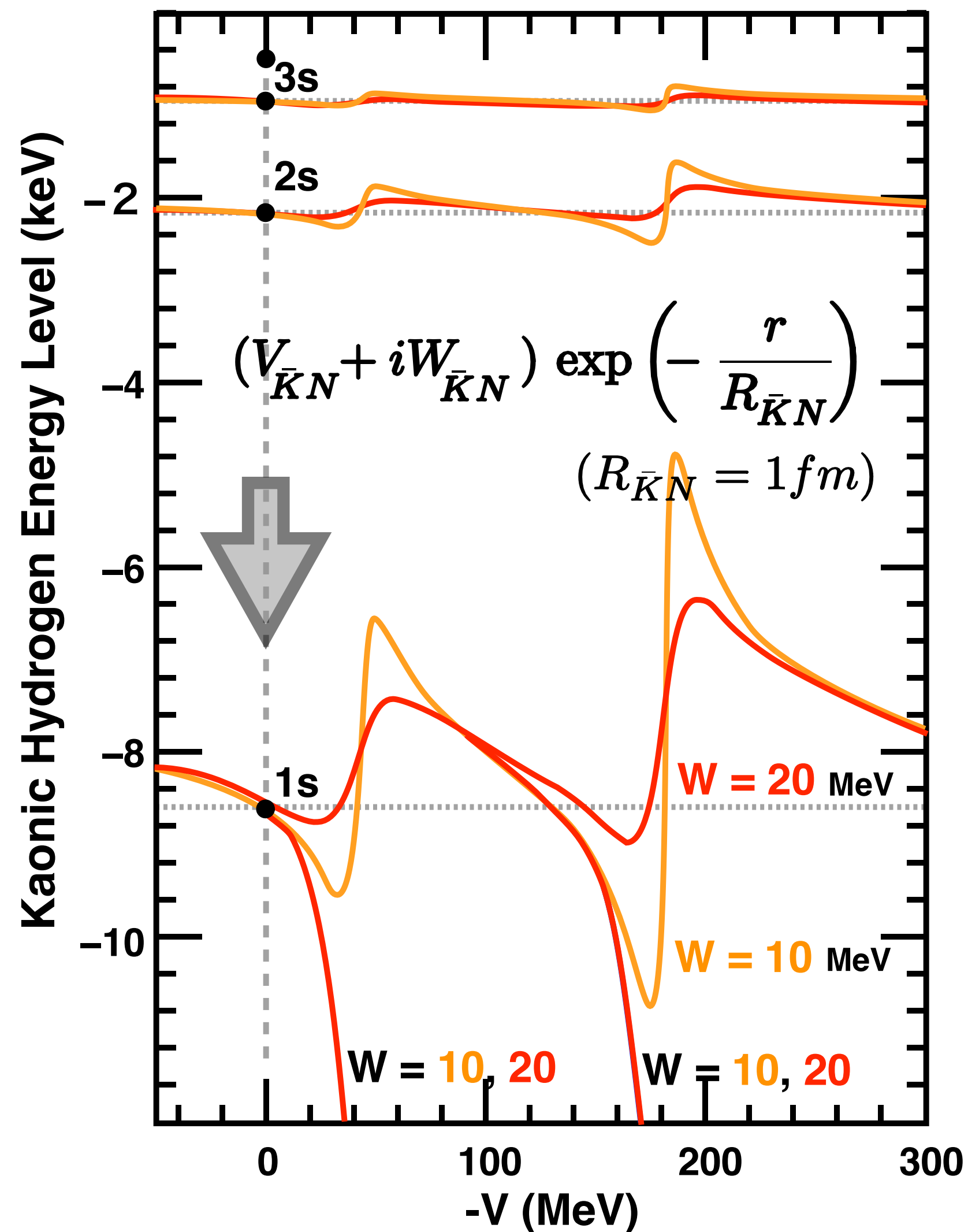

Theoretical calculations for realistic $\bar{K}N$ interaction

R. Seki, Phys. Rev. C **5** (1972) 1196

S. Baird et al., Nucl. Phys. A **392** (1983) 297

C.J. Batty, Nucl. Phys. A **508** (1990) 89c

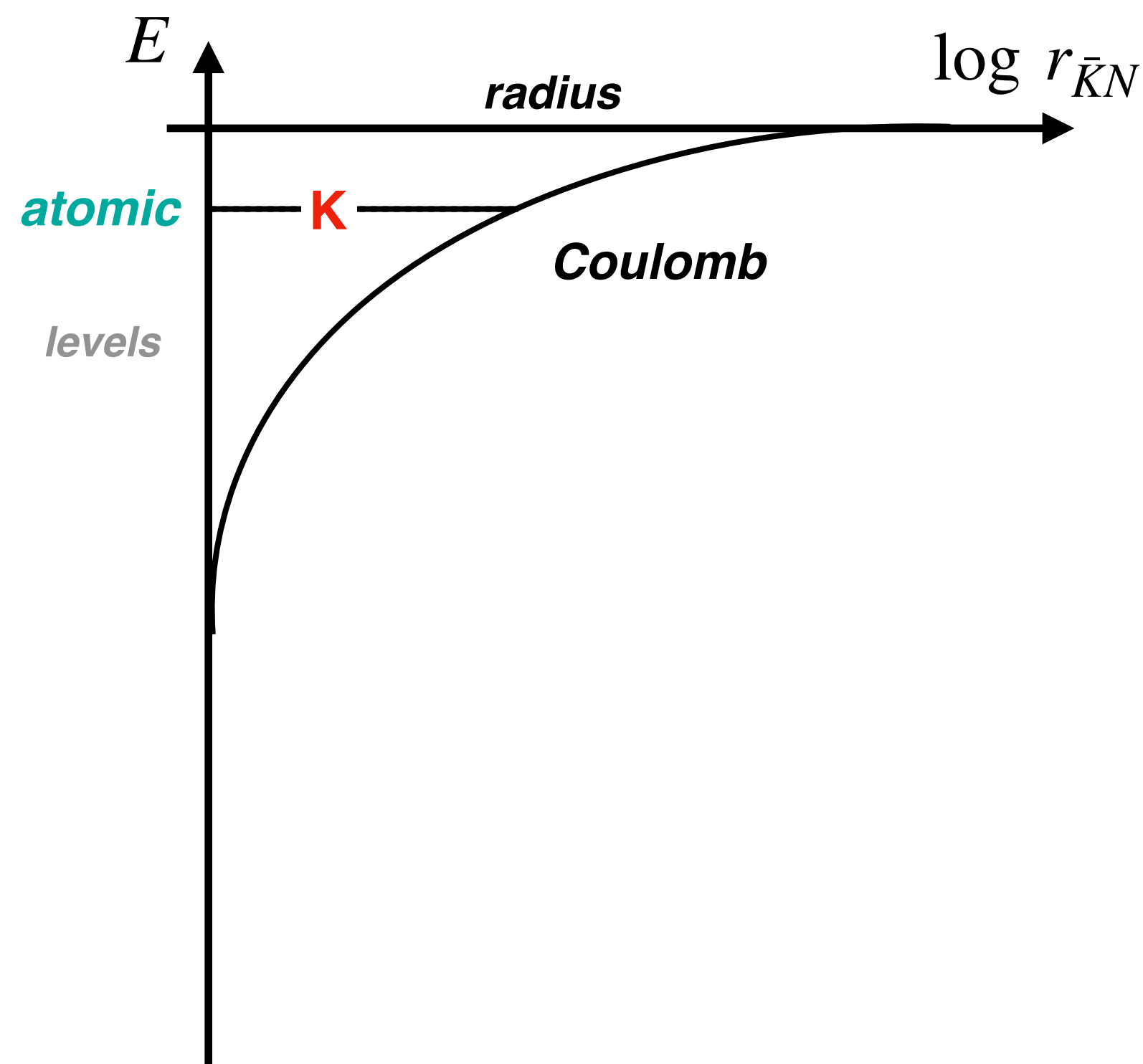

Illustrative Animation

Observed Shift was **REPULSIVE!**

Is $\bar{K}N$ interaction repulsive?

Coulomb + $\bar{K}N$ interaction

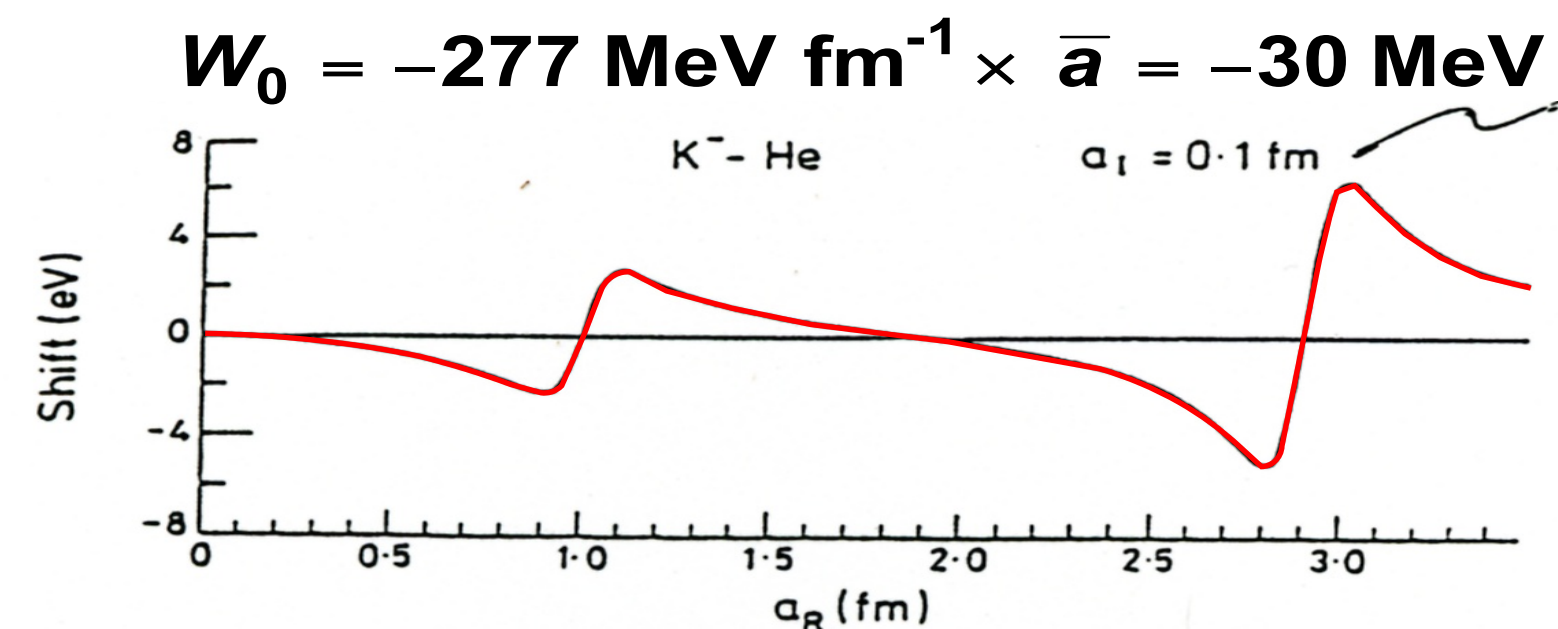
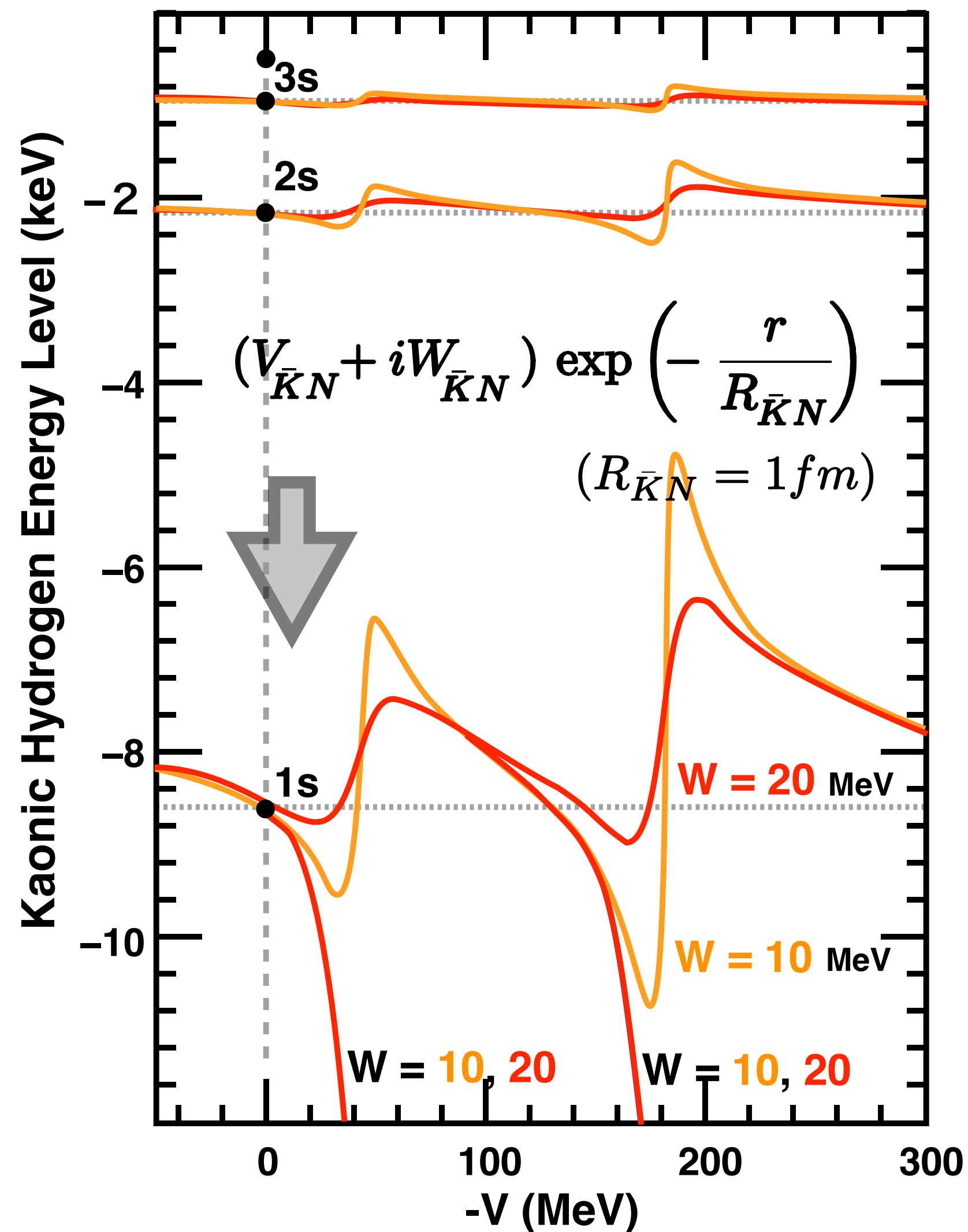

Theoretical calculations for realistic $\bar{K}N$ interaction

R. Seki, Phys. Rev. C5 (1972) 1196

S. Baird et al., Nucl. Phys. A392 (1983) 297

C.J. Batty, Nucl. Phys. A508 (1990) 89c

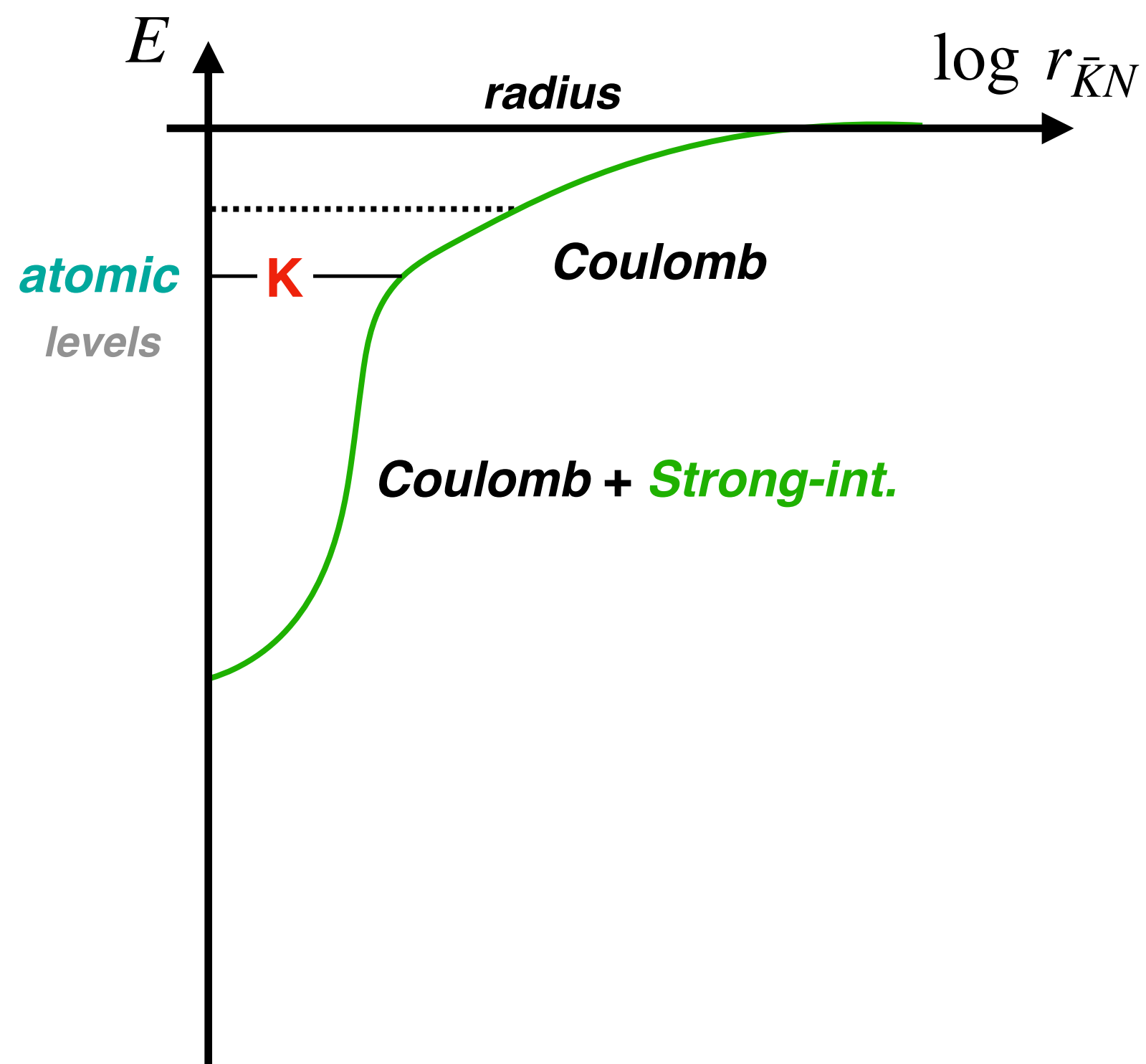

Illustrative Animation

Observed Shift was **REPULSIVE!**

Is $\bar{K}N$ interaction repulsive?

Coulomb + $\bar{K}N$ interaction

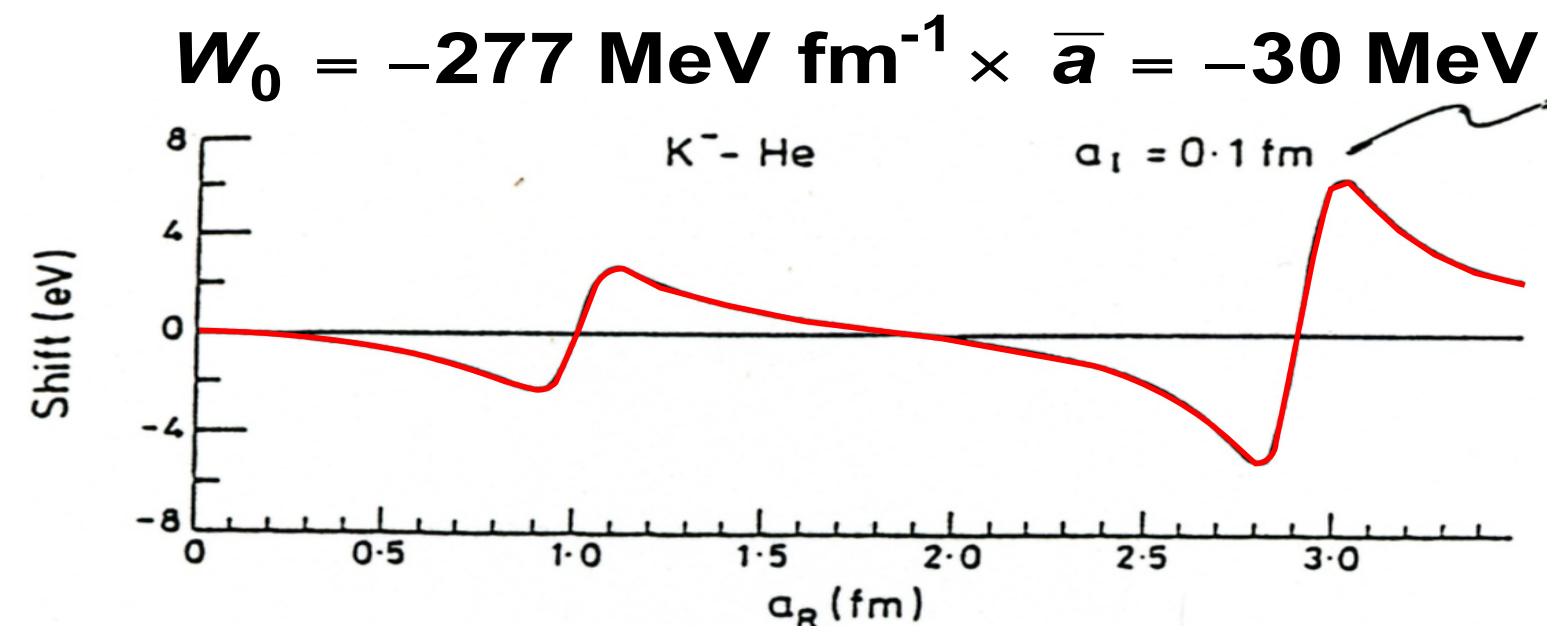
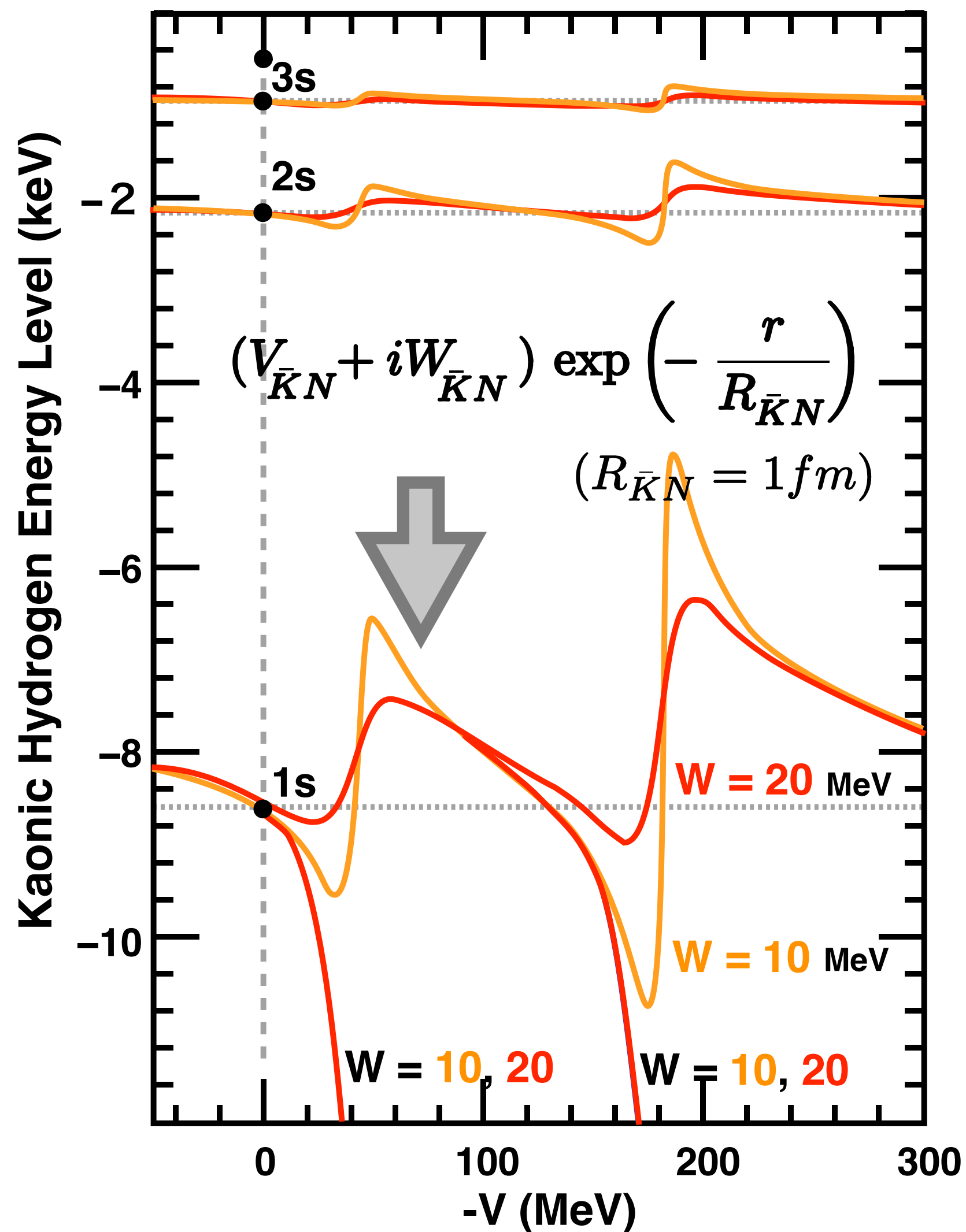

Theoretical calculations for realistic $\bar{K}N$ interaction

R. Seki, Phys. Rev. C5 (1972) 1196

S. Baird et al., Nucl. Phys. A392 (1983) 297

C.J. Batty, Nucl. Phys. A508 (1990) 89c

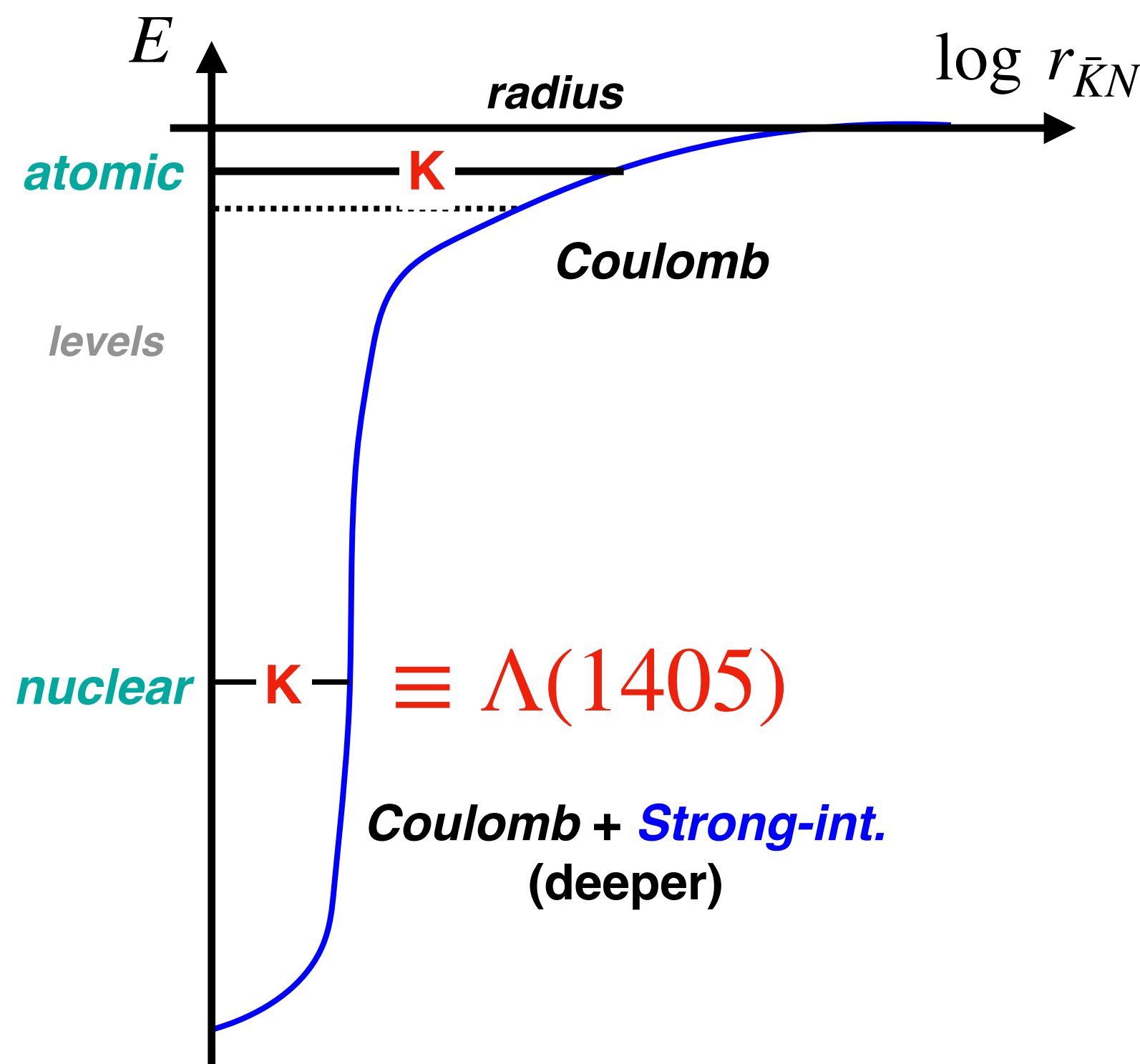

Illustrative Animation

Observed Shift was **REPULSIVE!**

Is $\bar{K}N$ interaction repulsive?

Coulomb + $\bar{K}N$ interaction

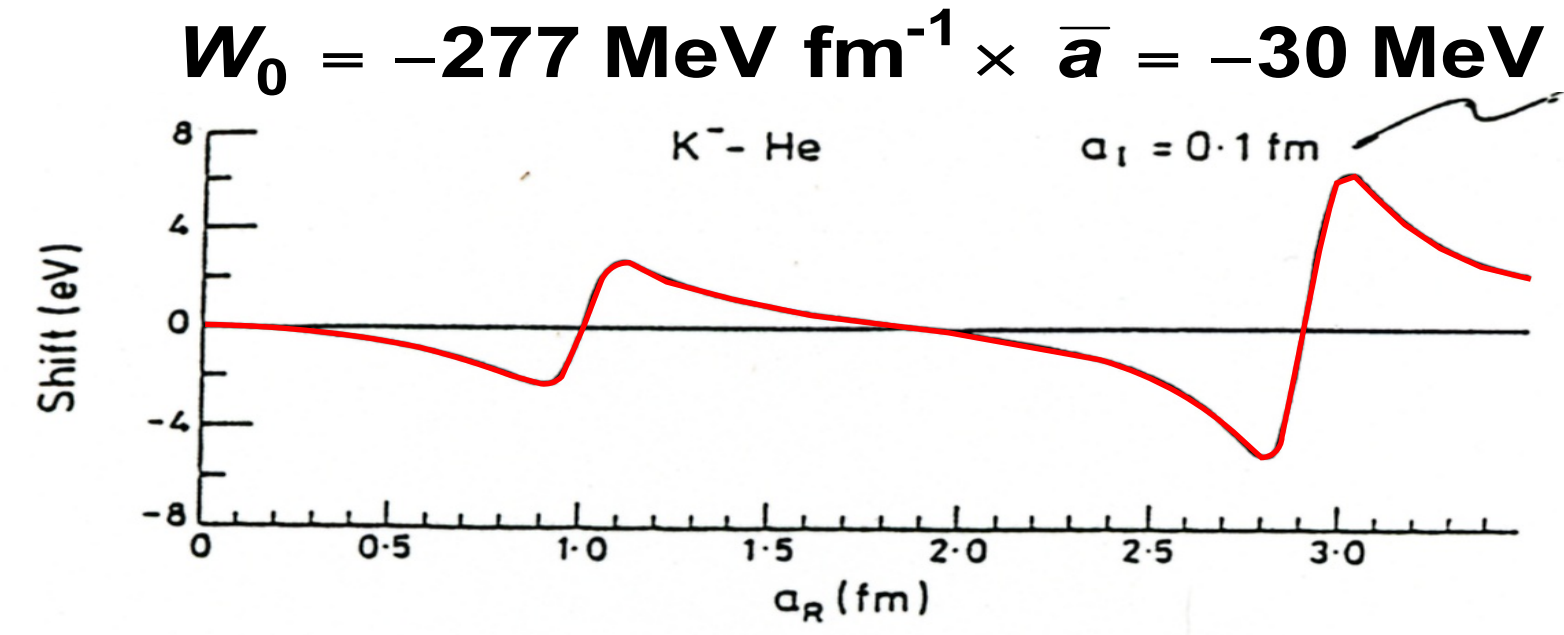
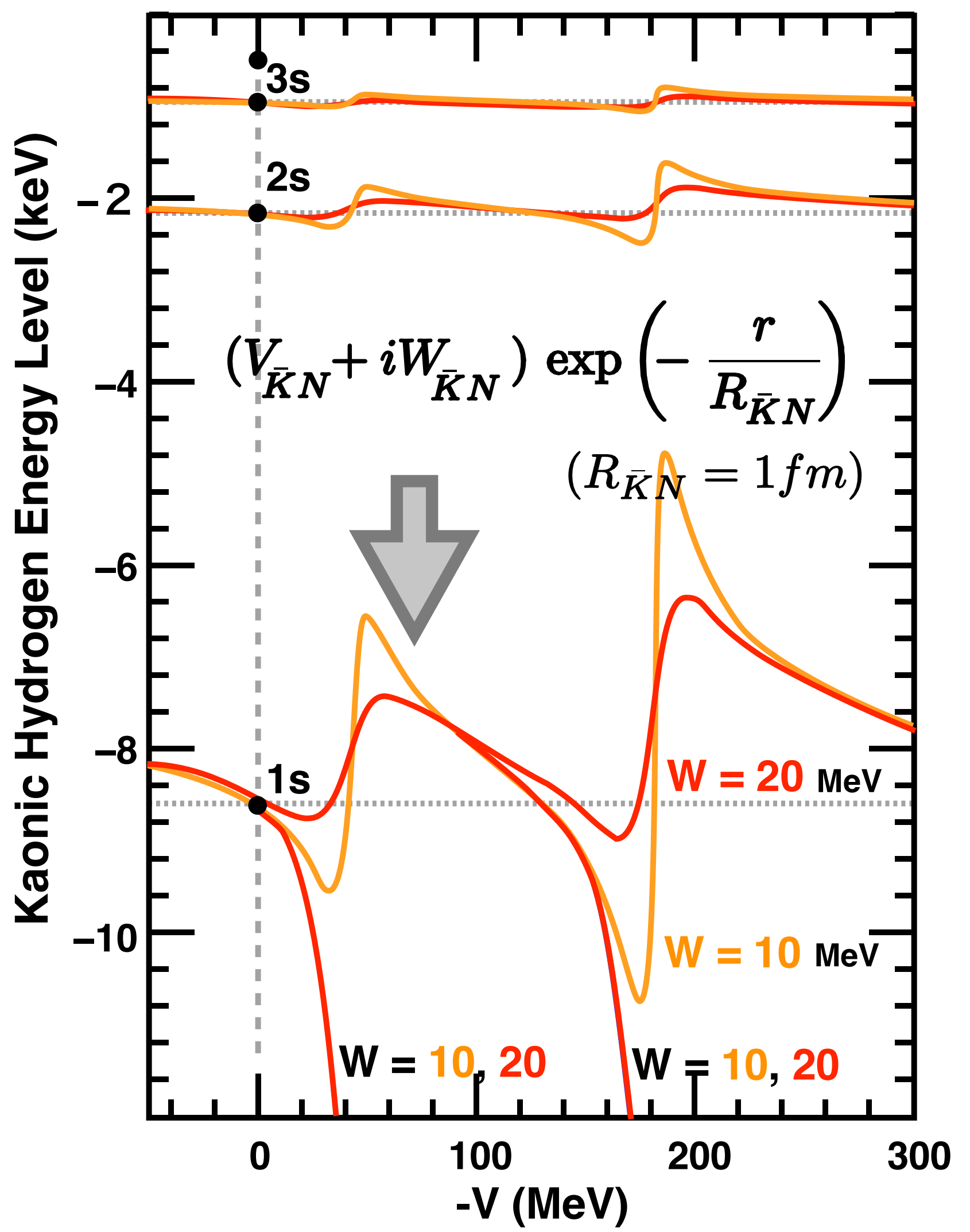

Theoretical calculations for realistic $\bar{K}N$ interaction

R. Seki, Phys. Rev. C5 (1972) 1196
 S. Baird et al., Nucl. Phys. A392 (1983) 297
 C.J. Batty, Nucl. Phys. A508 (1990) 89c

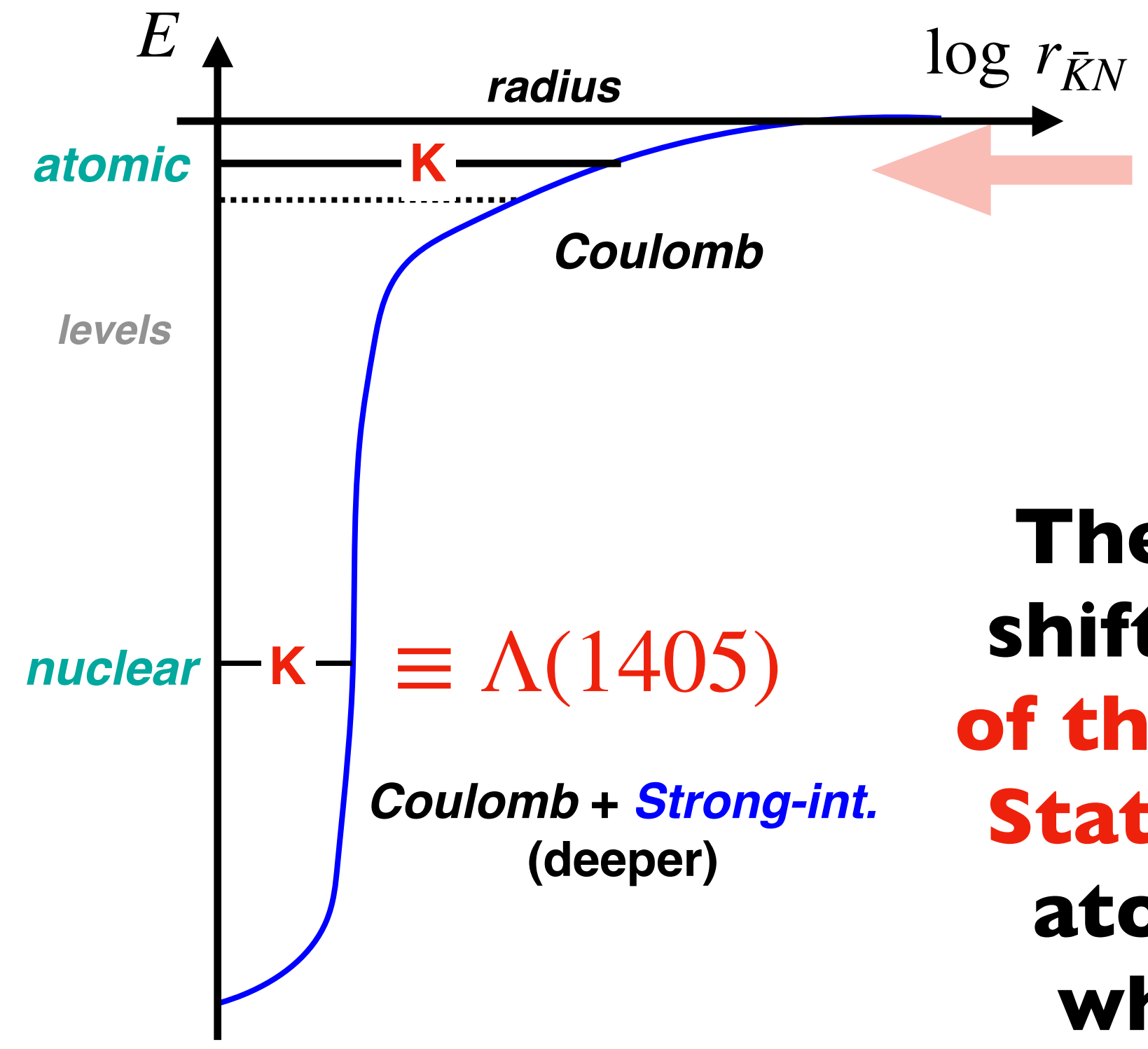

repulsive shift of atomic 1s

The sign flip of the energy shift suggests the existence of the Kaonic Nuclear Bound State because the repulsive atomic shift appears only when the bound state is formed!

Illustrative Animation

As a candidate of K^-p bound state, $\Lambda(1405)$ is the most natural

- Is it quark excited state of Λ baryon (qqq)?

$\Lambda(1405) = \bar{K}N$... a “molecule-like hadron composite”

R.H. Dalitz and S.F. Tuan, Ann. Phys., 3, 307 (1960)

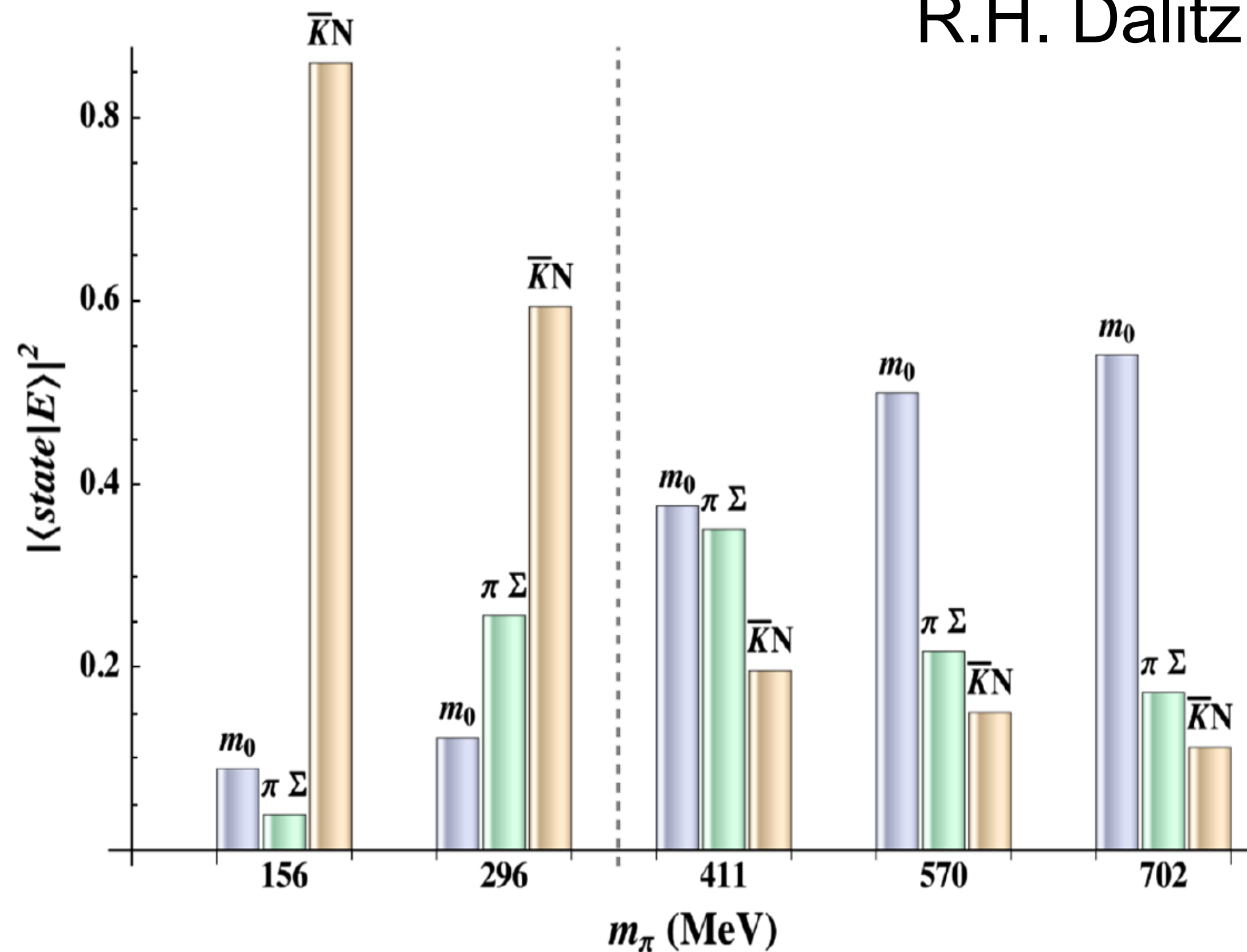

◆ supported by kaonic hydrogen data

Phys. Rev. Lett., 78, 3067 (1997)

◆ supported by Lattice QCD

J.M.M. Hall et al., Phys. Rev. Lett. 114(2015)132002.

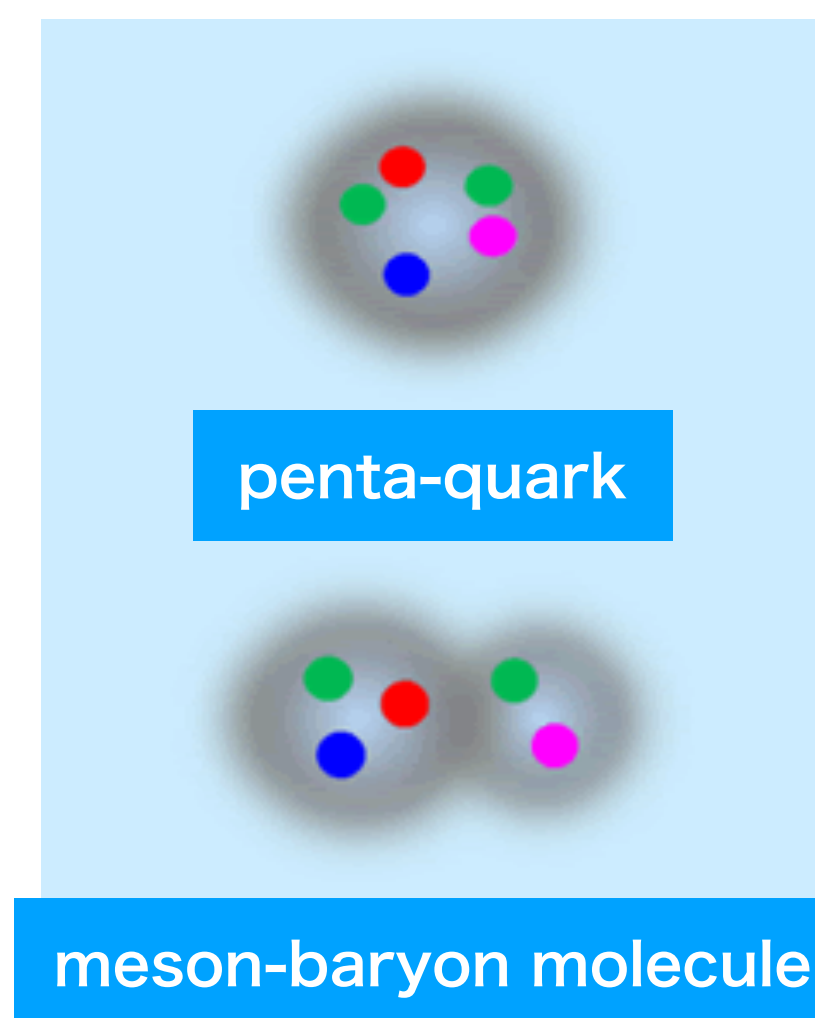

why not $\bar{K}NN$?

forming a nuclear bound state

Search for $\bar{K}NN$ bound state

Basic understanding of nuclei

- Nuclei consist of nucleons bound by nuclear force

nucleons (N):

qqq

meson: $\bar{q}q$

$q = u$ or d

Fermion:

Boson:

Pauli exclusion

particles can share a quantum state

Z [e]	1st	2nd	3rd
$+\frac{2}{3}$	u	c	t
$-\frac{1}{3}$	d	s	b

quark flavor

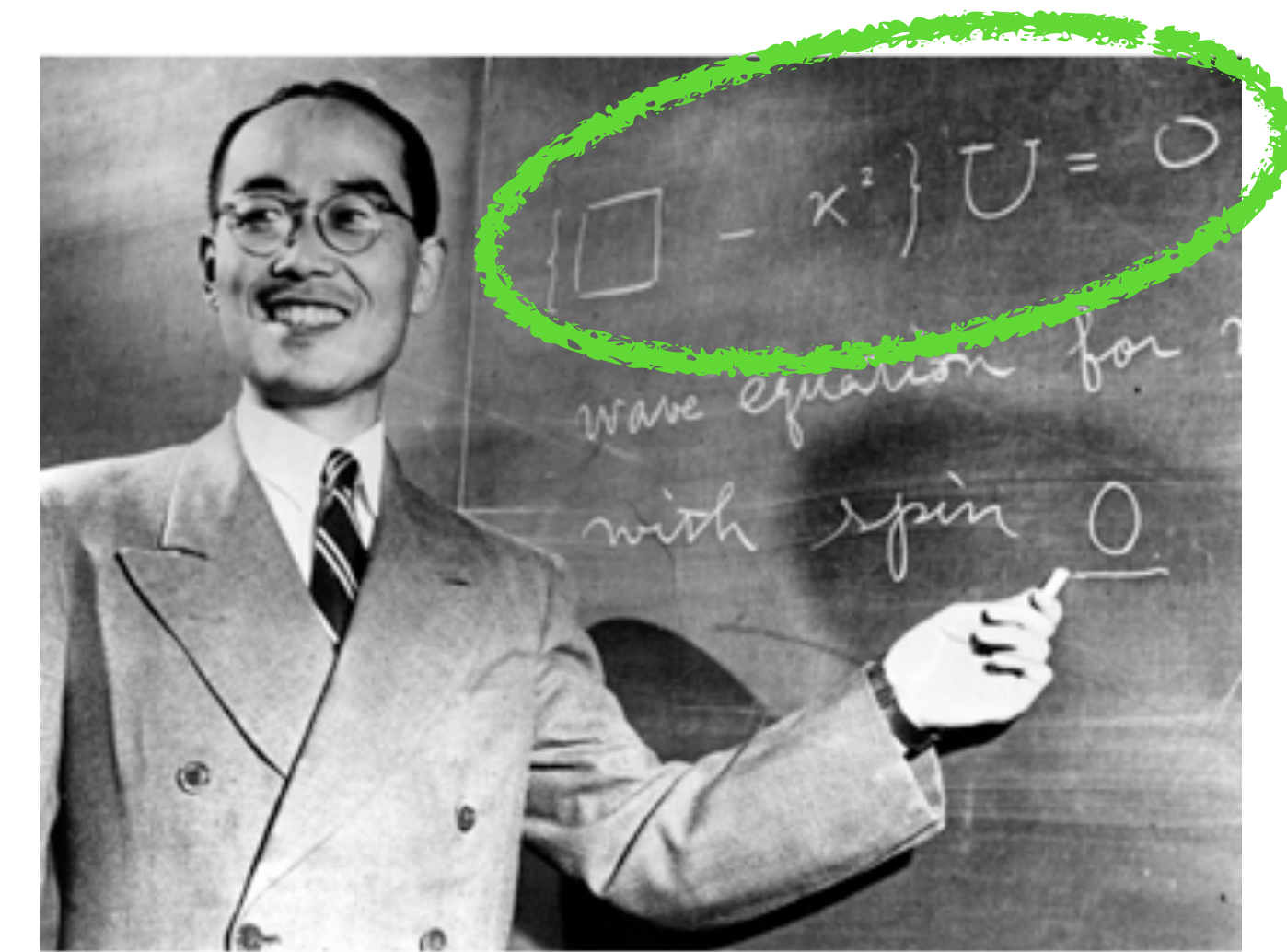

Yukawa Theorem tells :

- in nuclei, mesons are virtual particles and form nuclear potential

- in vacuum, mesons are real particles having own intrinsic masses

$$\phi \propto \frac{1}{r} \exp(-mr)$$

Long standing question :

Can meson be a constituent particle forming nuclei?

— Can meson form a quantum state as a particle ? —

... in the case of K-meson ...

\bar{K} ($\bar{q}s$) forms a bound state
with two nucleons

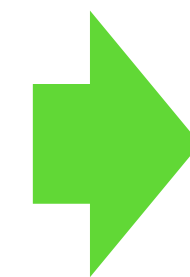

**totally new probe (impurity)
to study inside nuclei**

\bar{K} meson ($K^-: \bar{u}s, \bar{K}^0: \bar{d}s$)

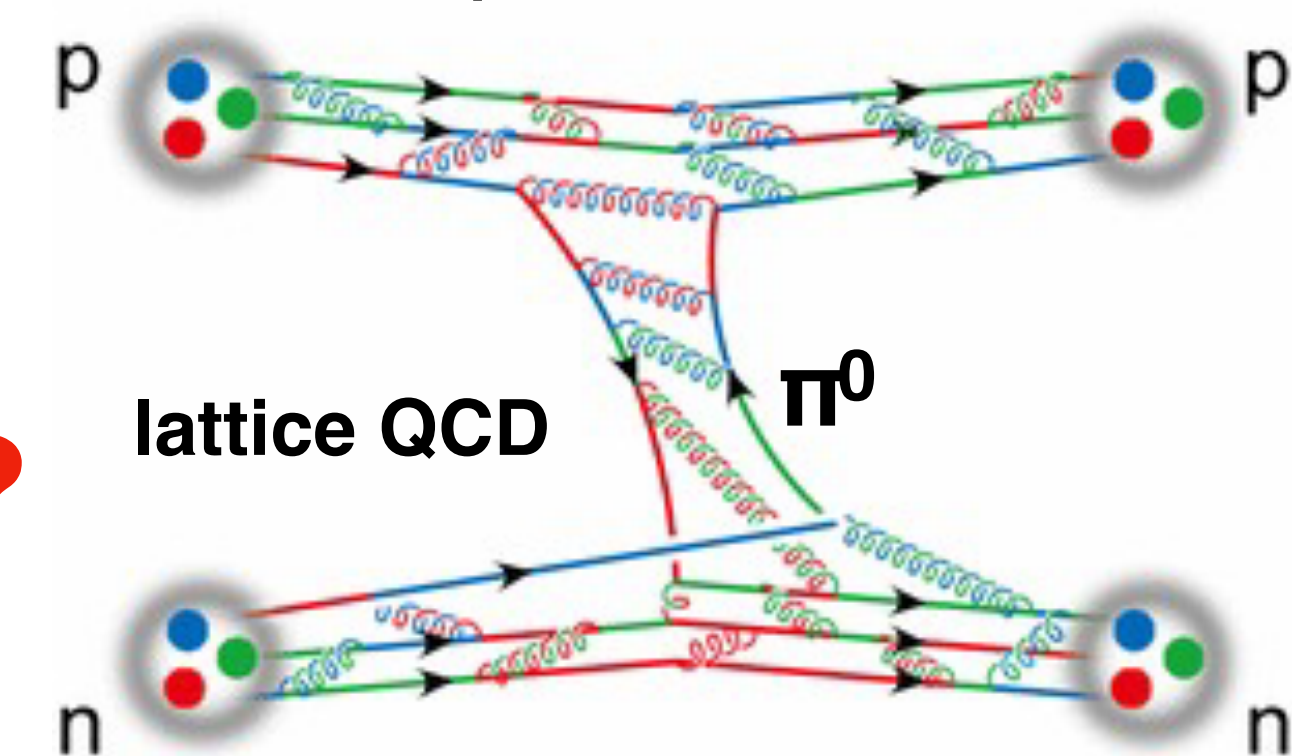

Beyond Conventional
Understanding

J-PARC E15: “ K^-pp ” Exploration

$K^- + {}^3\text{He} (ppn)$

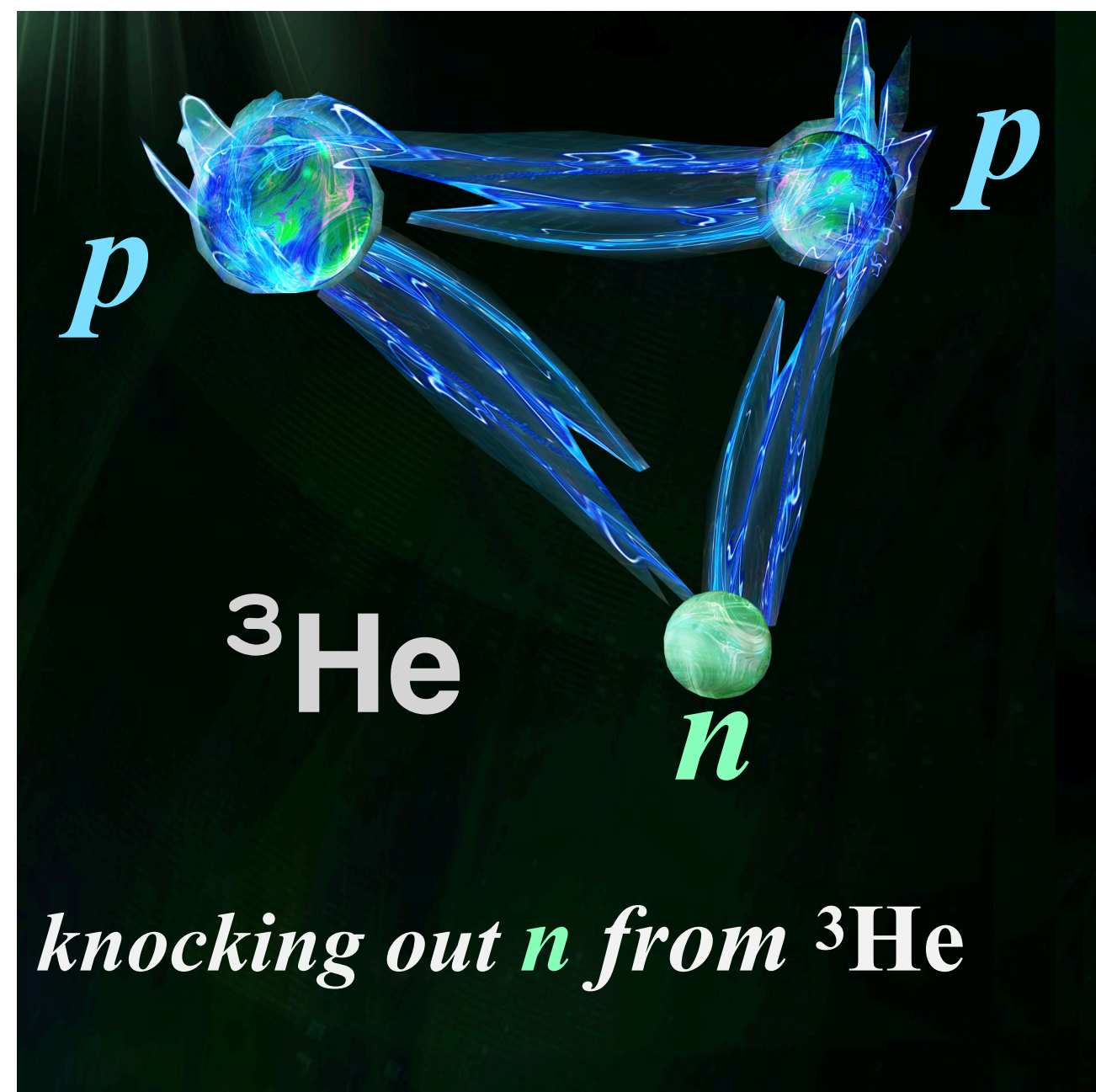

$(K^- + pp) + n$

substitute n in ${}^3\text{He}$ by K^-

J-PARC E15: “ K^-pp ” Exploration

$K^- + {}^3\text{He} (ppn)$

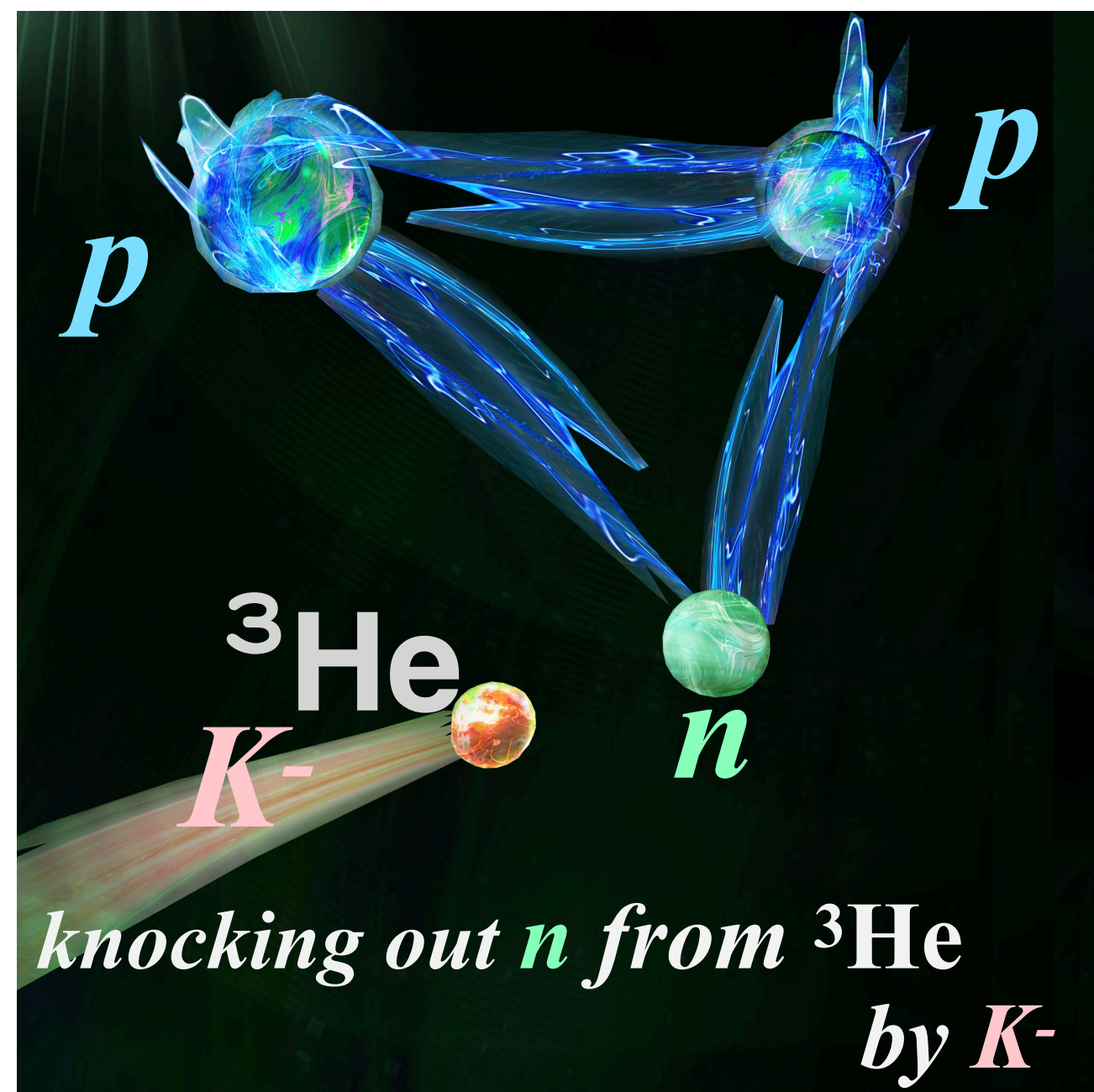

$(K^- + pp) + n$

substitute n in ${}^3\text{He}$ by K^-

J-PARC E15: “ K^-pp ” Exploration

$K^- + {}^3\text{He} (ppn)$

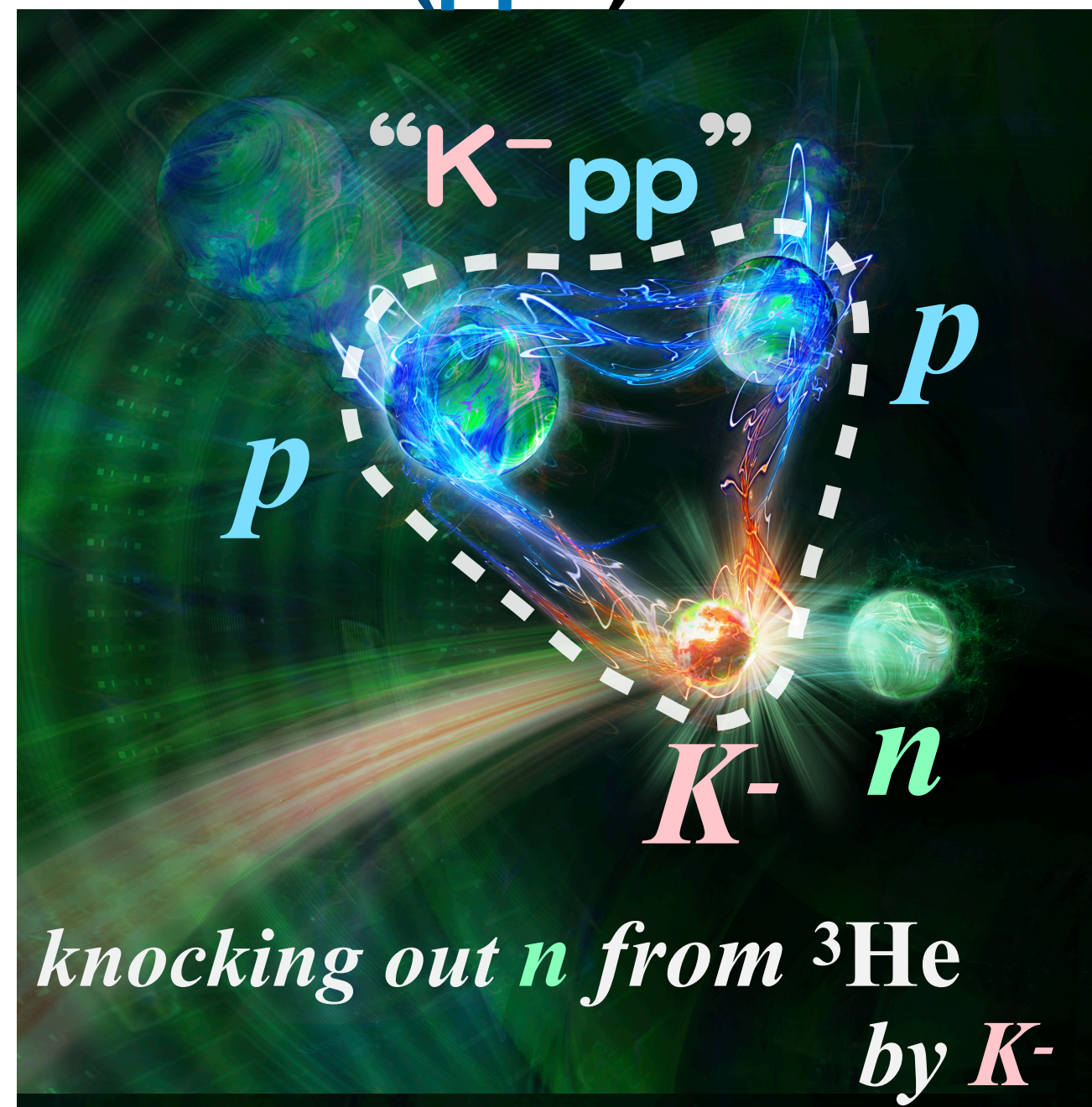

If “ K^-pp ” exists, a peak will be formed in invariant mass spectrum below $M(K^-pp)$

$$M(K^-pp) \equiv m_{K^-} + 2m_p$$



$(K^- + pp) + n$

substitute n in ${}^3\text{He}$ by K^-

J-PARC E15: “ K^-pp ” Exploration

$K^- + {}^3\text{He} (ppn)$

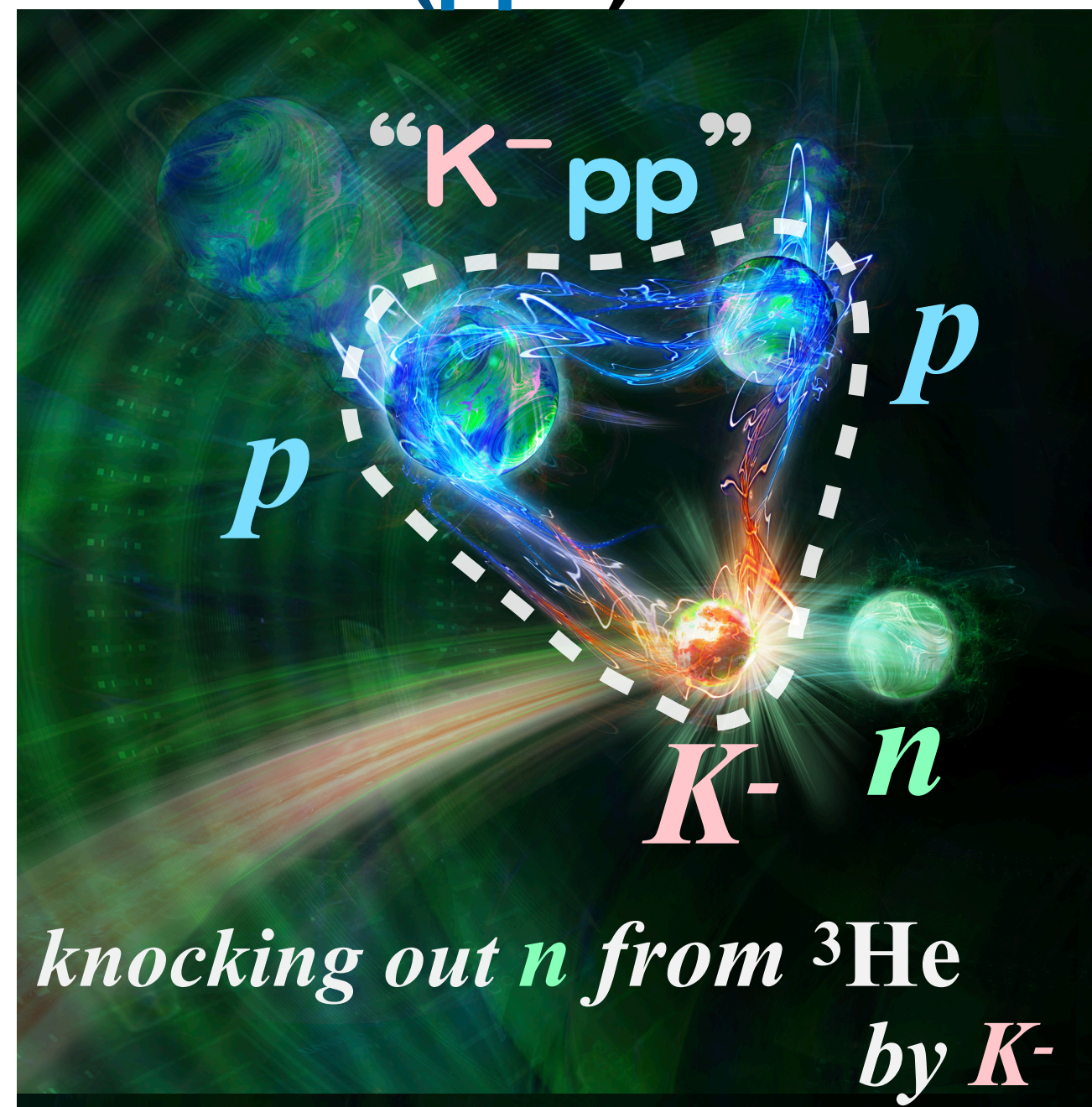

$(K^- + pp) + n$

substitute n in ${}^3\text{He}$ by K^-

If “ K^-pp ” exists, a peak will be formed in invariant mass spectrum below $M(K^-pp)$

$$M(K^-pp) \equiv m_{K^-} + 2m_p$$

kinematically identified

$K^- + {}^3\text{He} \rightarrow (K^- + pp) + n$: formation

$(K^- + pp) \rightarrow \Lambda + p$: decay (M, q)

identified as charged particles

select $K^- + {}^3\text{He} \rightarrow (\Lambda + p) + n$ events,
analyze *invariant mass* M of $(K^- + pp)$ -system
and *momentum transfer* q to the system

provides multi-dimensional kinematical information

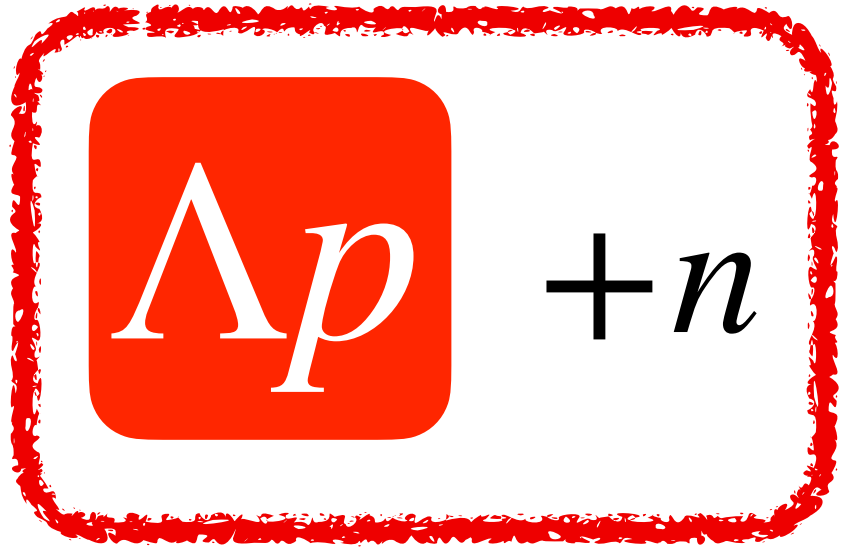

events

Acceptance corrected event distribution on (M, q)

on (M, q) -plane

q-distribution: system size

— high- q capture happens if the system is compact —

M-distribution: binding energy & absorption width

— sensitive to $\bar{K}N$ interaction —

reconstructed " $\bar{K}N$ " mass (M) →

binding threshold

q [GeV/c]

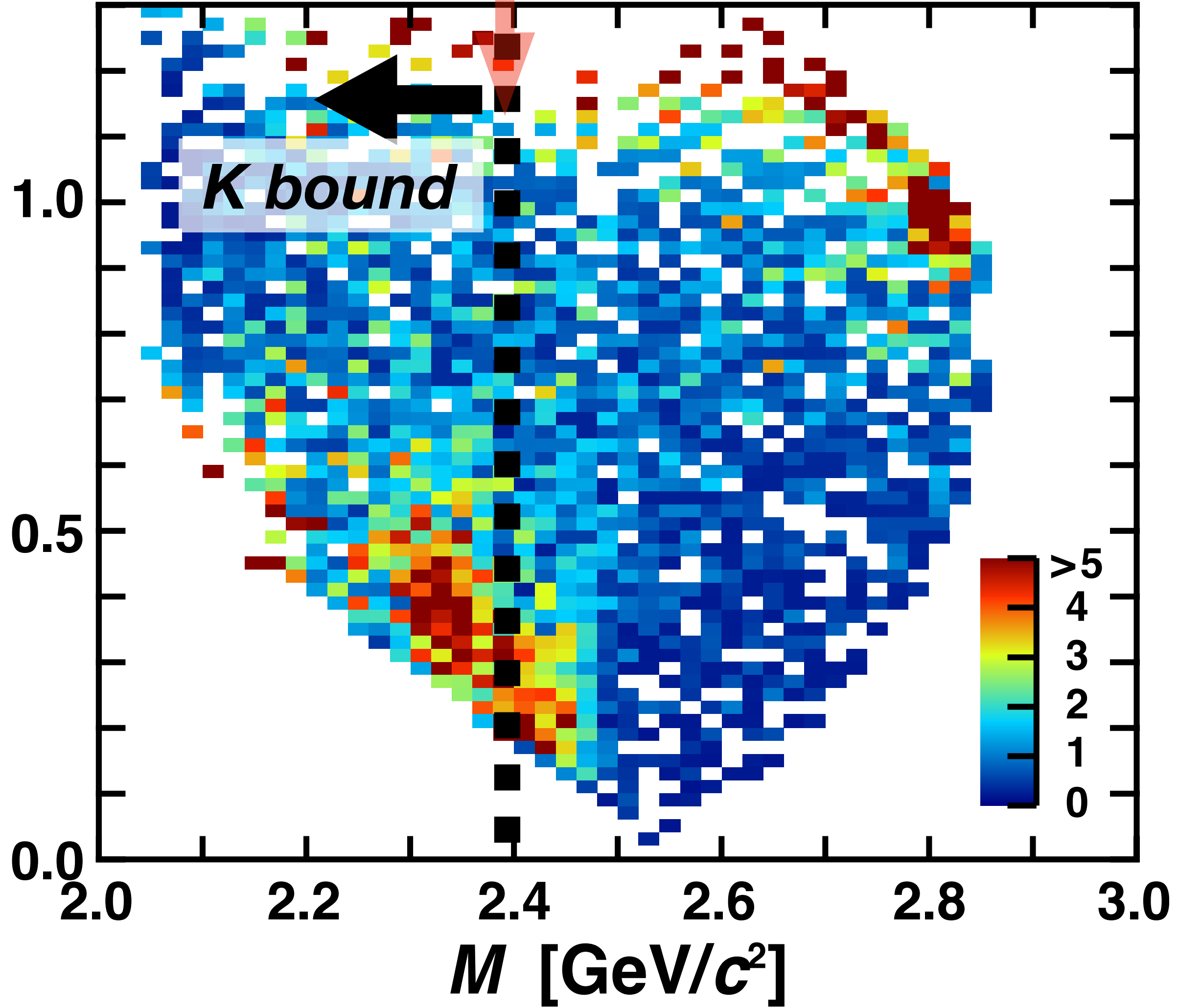

momentum transfer (q) to " $\bar{K}N$ "

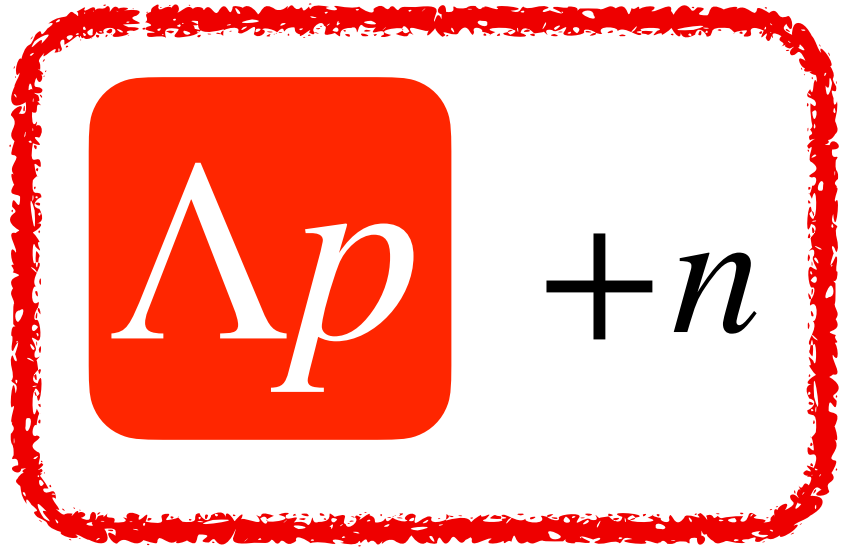

events

Acceptance corrected event distribution on (M, q)

on (M, q) -plane

q-distribution: system size

— high- q capture happens if the system is compact —

M-distribution: binding energy & absorption width

— sensitive to $\bar{K}N$ interaction —

The K-pp signal is clearly seen on (M, q) -plane!

— relatively deep and wide, and extended to high- q region —

reconstructed " $\bar{K}N$ " mass (M)

binding threshold

q [GeV/c]

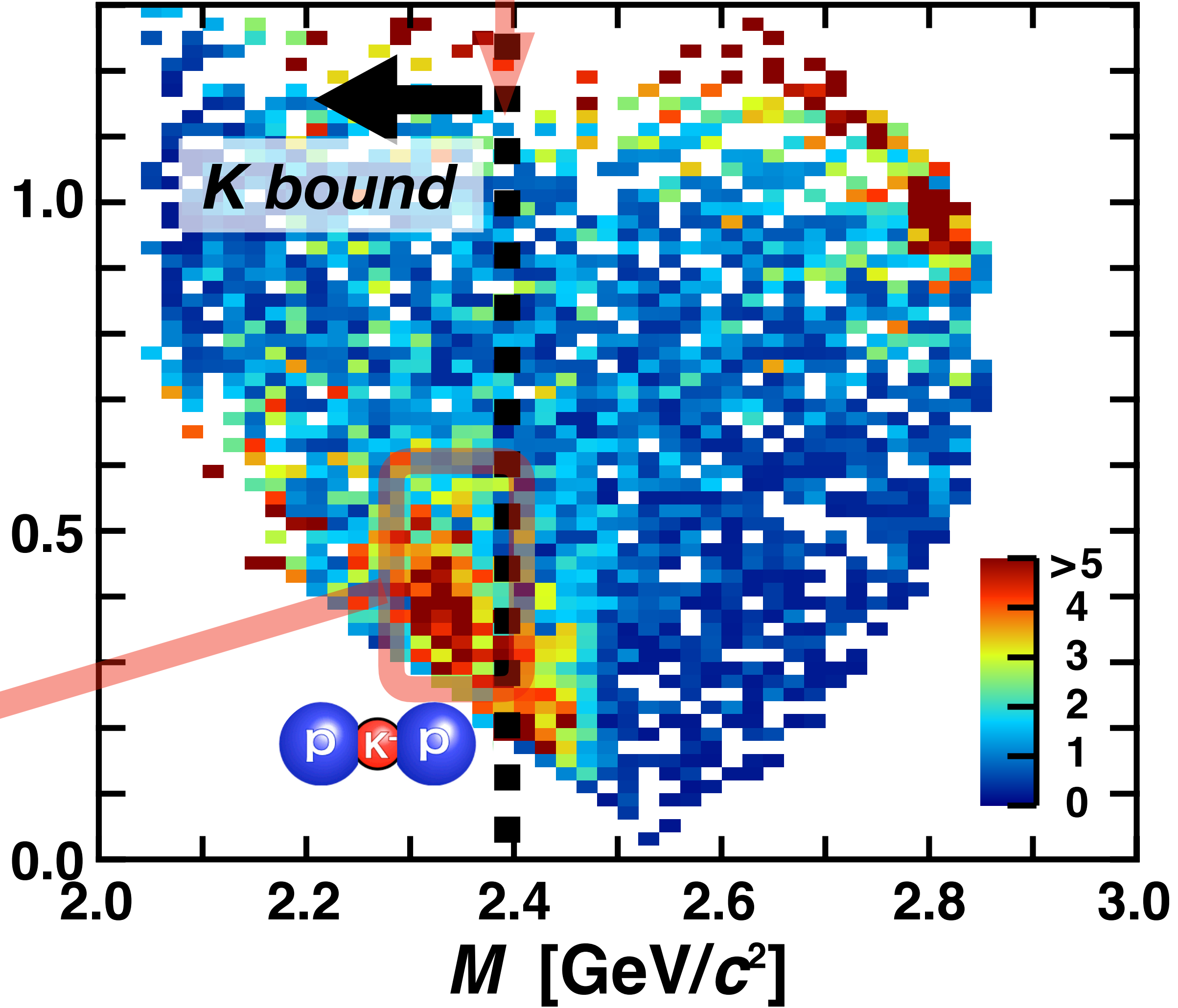

momentum transfer (q) to " $\bar{K}N$ "

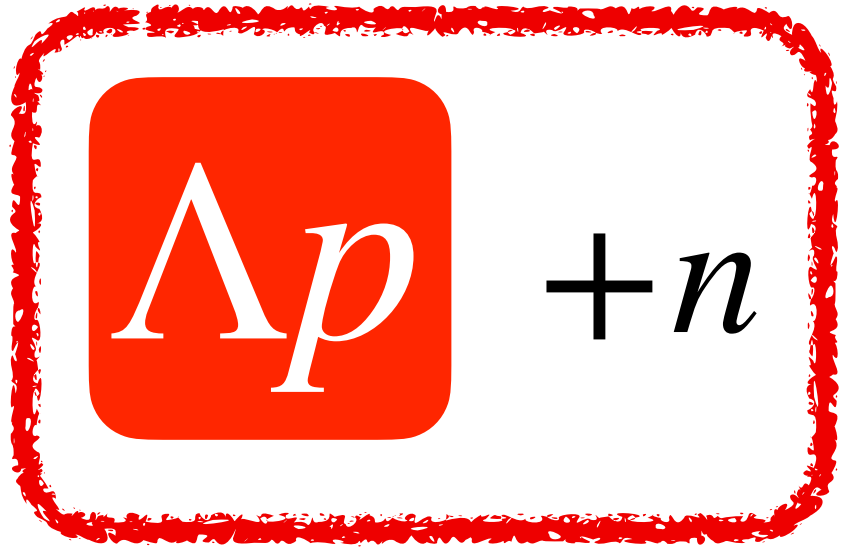

events

Acceptance corrected event distribution on (M, q)

on (M, q) -plane

q-distribution: system size

— high- q capture happens if the system is compact —

M-distribution: binding energy & absorption width

— sensitive to $\bar{K}N$ interaction —

The K-pp signal is clearly seen on (M, q) -plane!

— relatively deep and wide, and extended to high- q region —

reconstructed " $\bar{K}NN$ " mass (M)

binding threshold

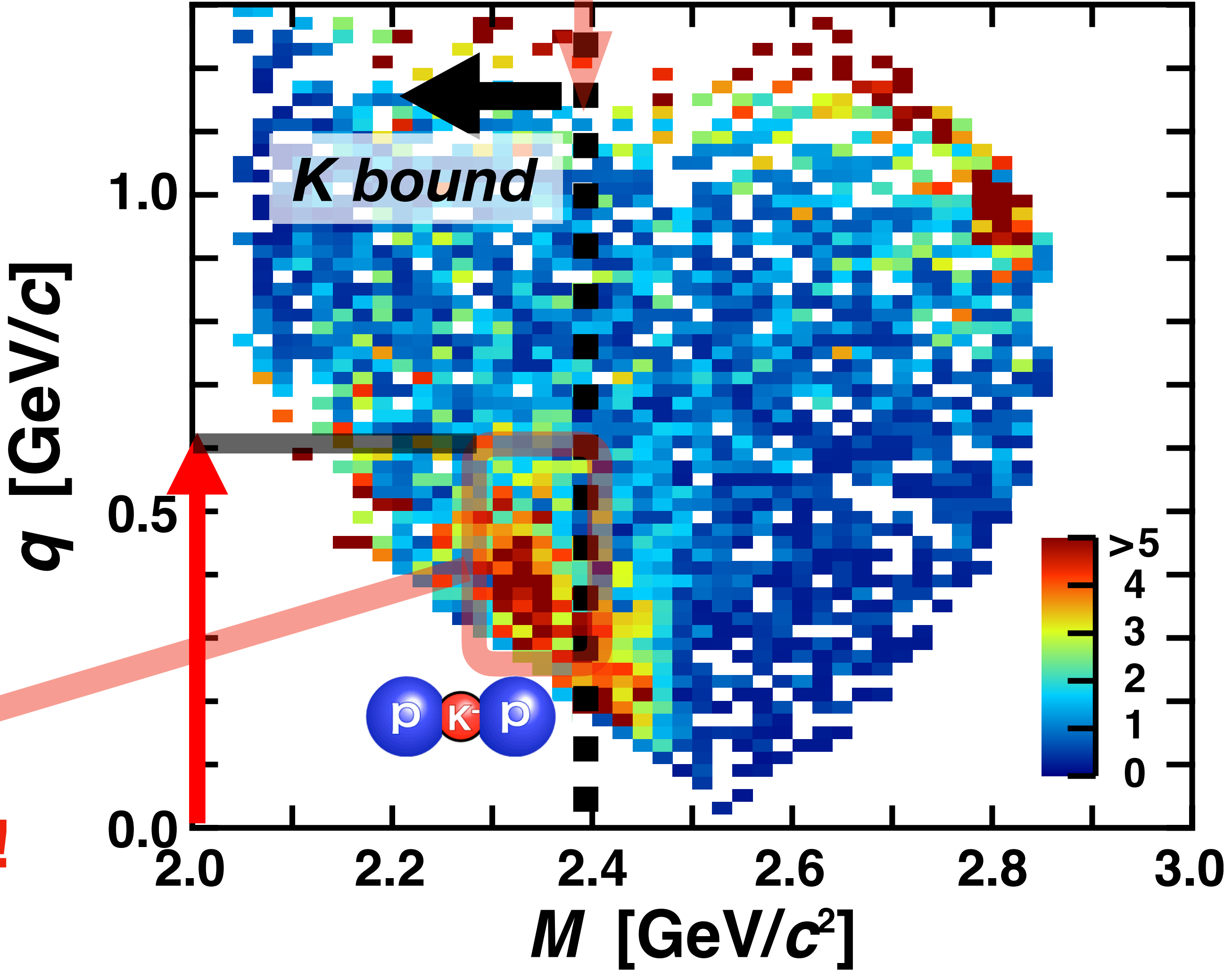

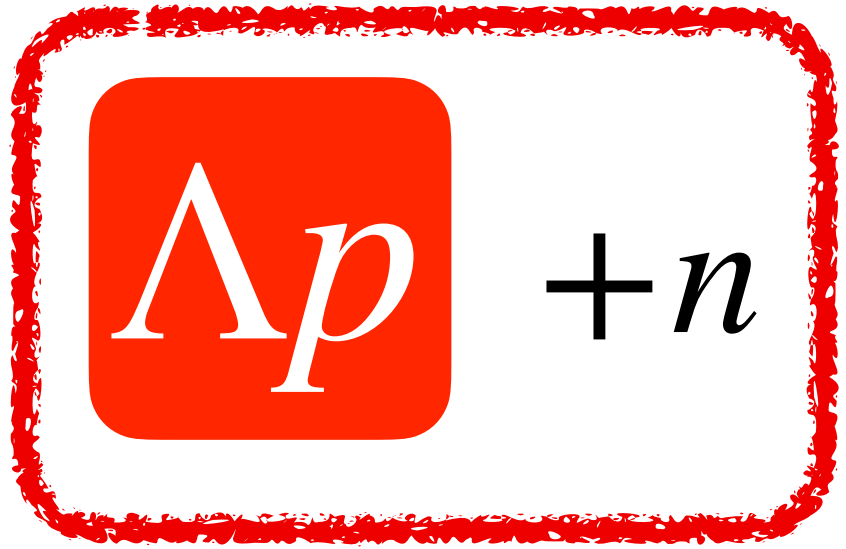

$\Lambda p + n$ events

Acceptance corrected event distribution on (M, q)

on (M, q) -plane

q-distribution: system size

— high- q capture happens if the system is compact —

M-distribution: binding energy & absorption width

— sensitive to $\bar{K}N$ interaction —

The K-pp signal is clearly seen on (M, q) -plane!

— relatively deep and wide, and extended to high- q region —

reconstructed " $\bar{K}N$ " mass (M)

binding threshold

q [GeV/c]

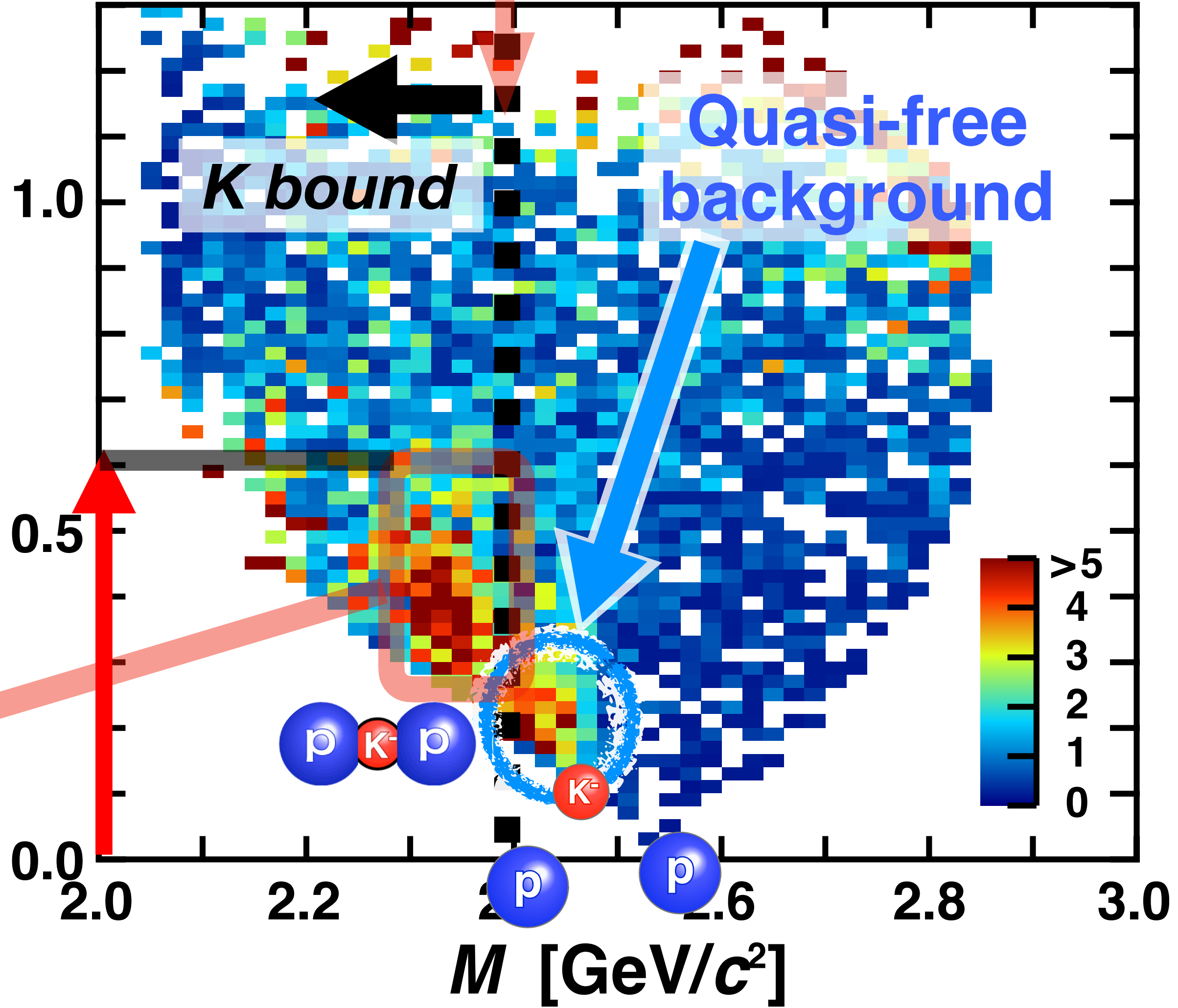

momentum transfer (q) to " $\bar{K}N$ "

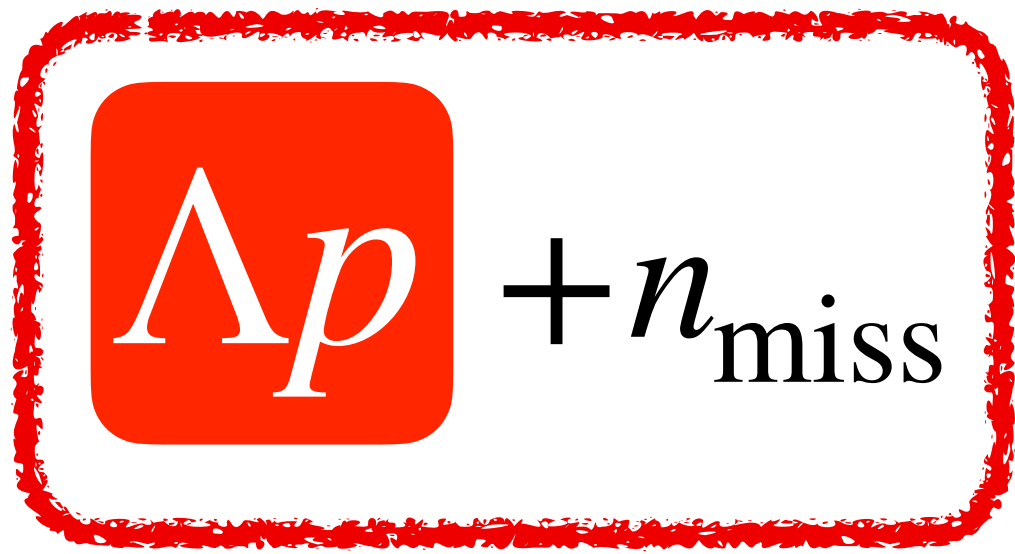

Phenomenological model fitting function in (m, q) -plane

ρ : Lorentz-invariant phase-space

$$f_{\bar{K}NN}(m, q) \times \rho_{\{\Lambda pn\}}(m, q) \quad f_{QF-\bar{K}}(m, q) \times \rho_{\{\Lambda pn\}}(m, q)$$

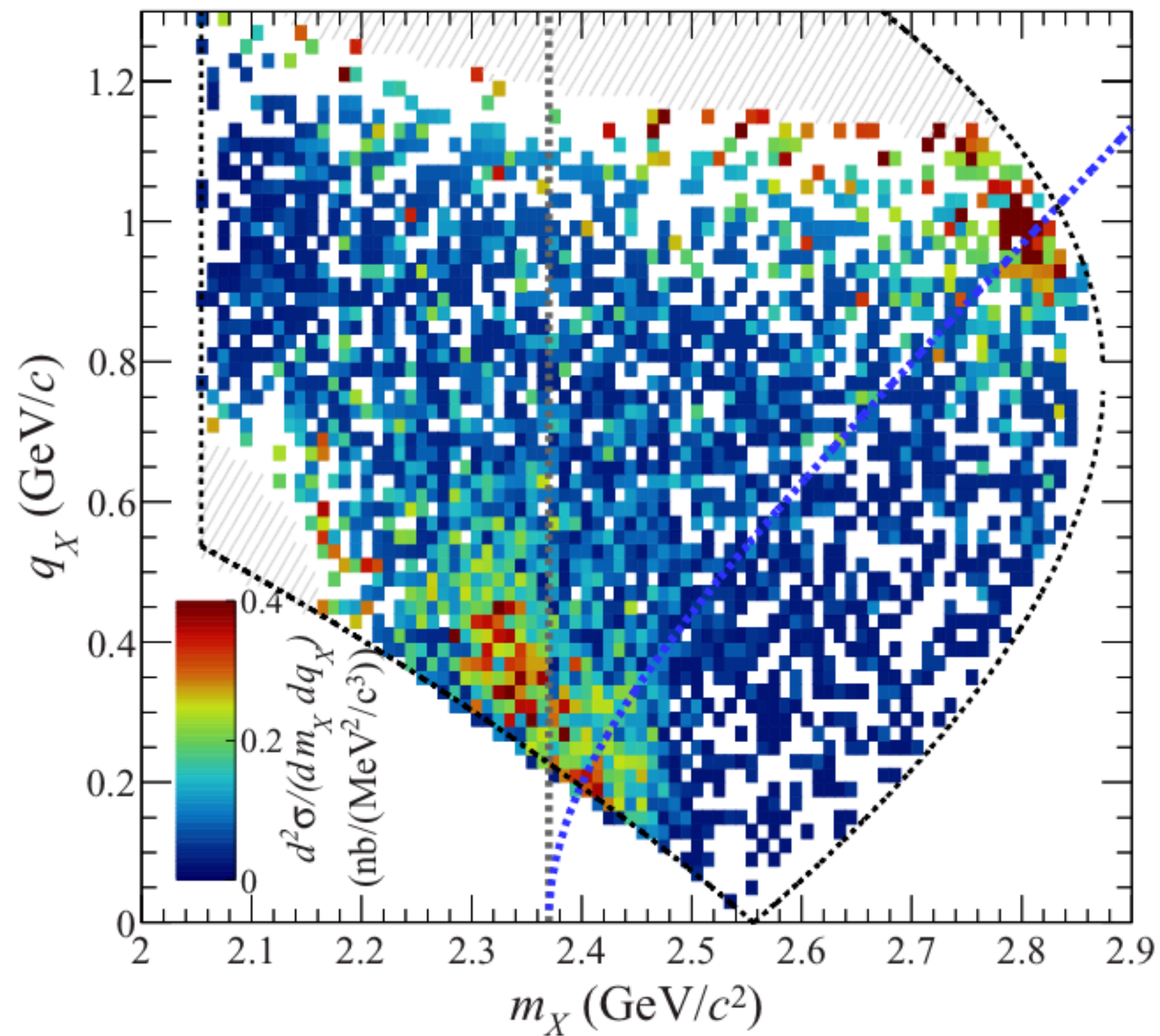

$\bar{K}NN$ production

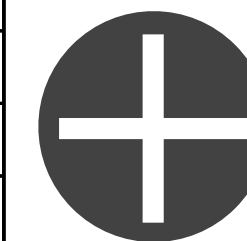
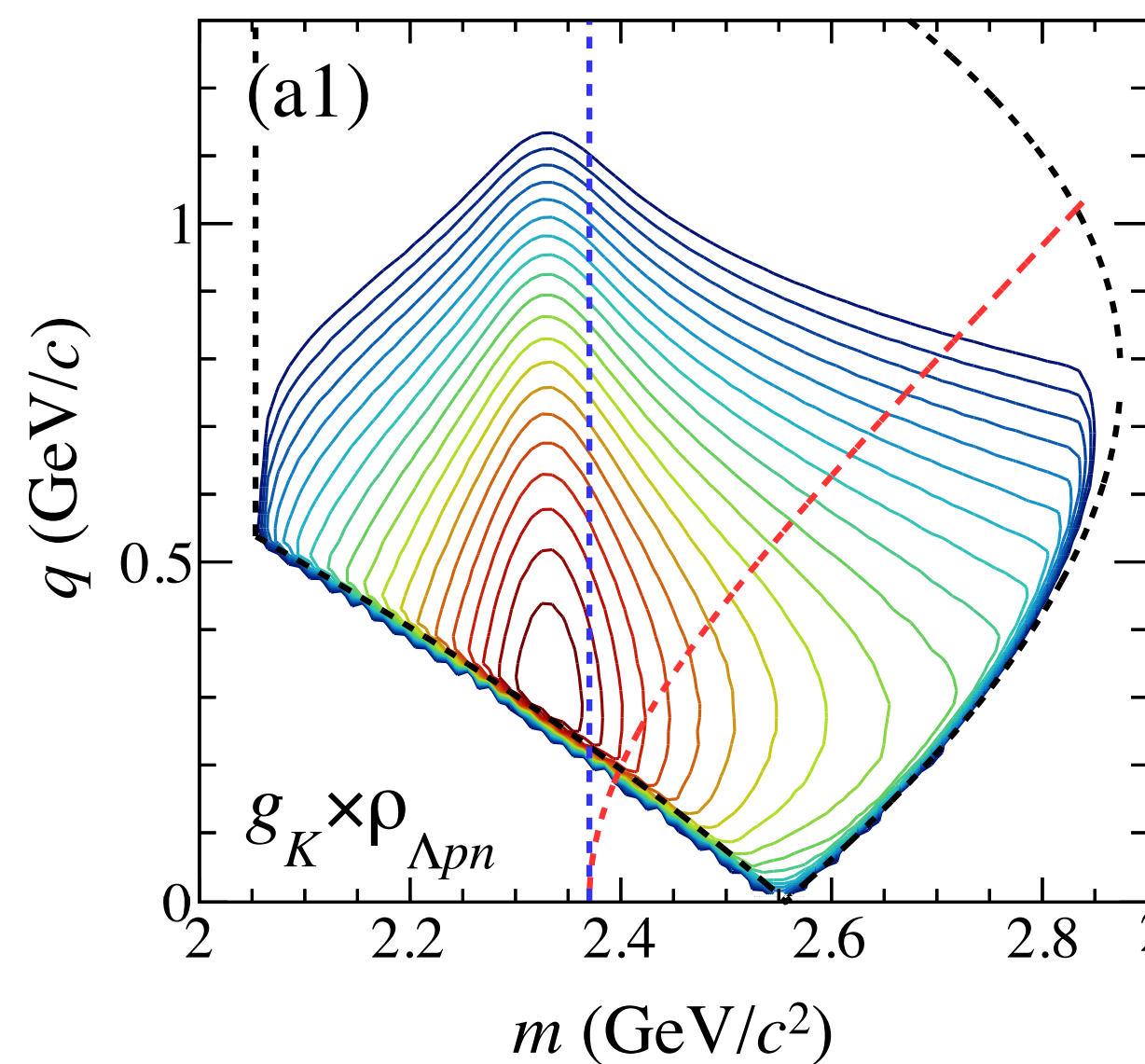

QF- \bar{K} absorption

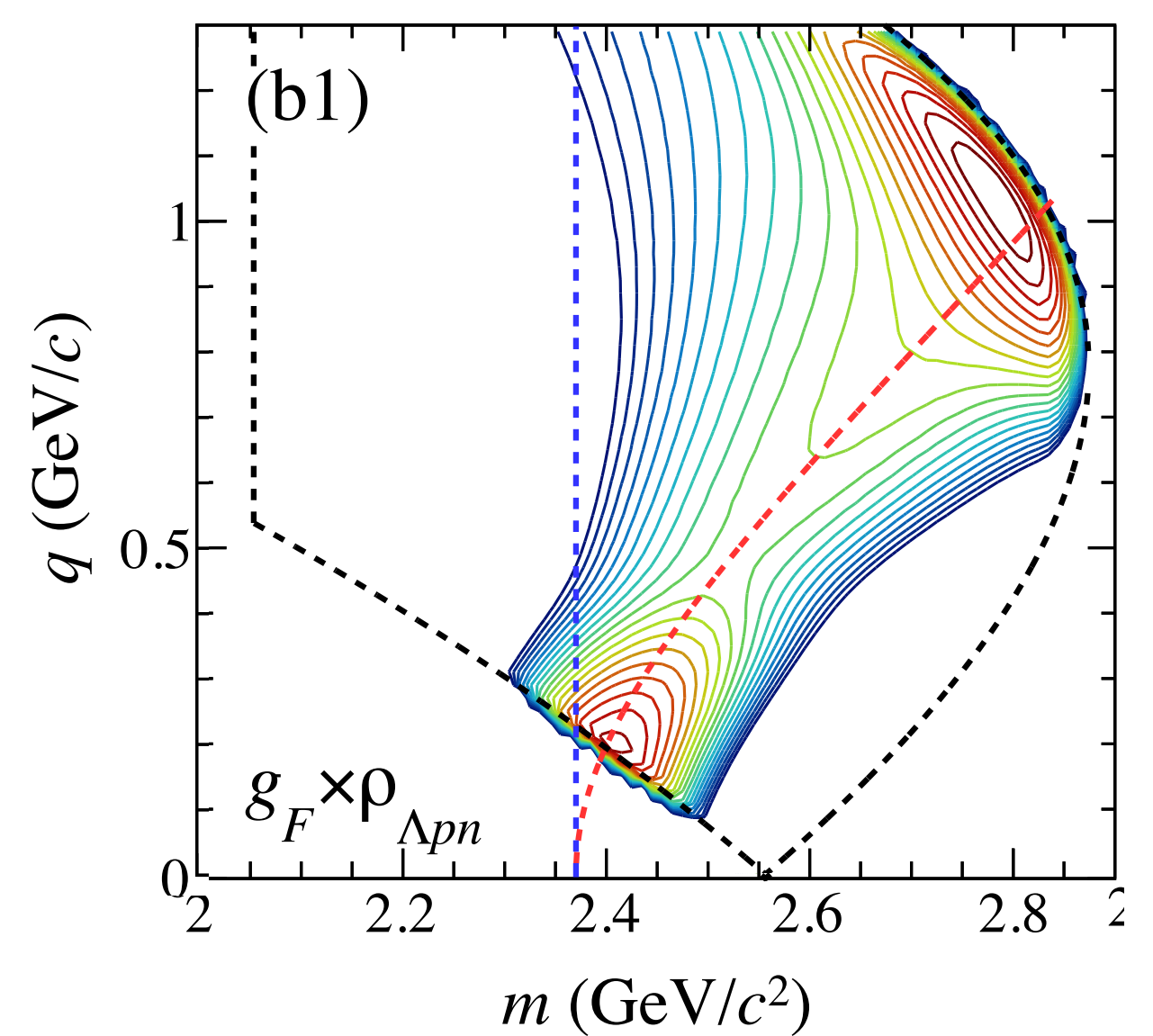

$$f_{\bar{K}NN}(m, q) : \quad B.W.(m) \times \text{form factor}(q)$$

$$f_{QF-\bar{K}}(m, q) : \quad \text{phenomenological}$$

PWIA based interpretation

(plane wave impulse approximation)

$$\sigma(M, q) \propto \rho_{3B}(M, q) \times \frac{(\Gamma_{Kpp}/2)^2}{(M - M_{Kpp})^2 + (\Gamma_{Kpp}/2)^2} \times \exp\left(-\frac{q^2}{Q_{Kpp}^2}\right)$$

Differential
cross section

PWIA based interpretation

(plane wave impulse approximation)

$$\sigma(M, q) \propto \underbrace{\rho_{3B}(M, q)}_{\text{Differential cross section}} \times \underbrace{\frac{(\Gamma_{Kpp}/2)^2}{(M - M_{Kpp})^2 + (\Gamma_{Kpp}/2)^2}}_{\text{Lorentz invariant phase space } (\Lambda p)} \times \exp\left(-\frac{q^2}{Q_{Kpp}^2}\right)$$

PWIA based interpretation

— from time integral —

B.W. / Lorentzian

(plane wave impulse approximation)

$$\sigma(M, q) \propto$$

$$\rho_{3B}(M, q) \times$$

Differential
cross section

Lorentz invariant
phase space (Λp)

$$\frac{(\Gamma_{Kpp}/2)^2}{(M - M_{Kpp})^2 + (\Gamma_{Kpp}/2)^2} \times \exp\left(-\frac{q^2}{Q_{Kpp}^2}\right)$$

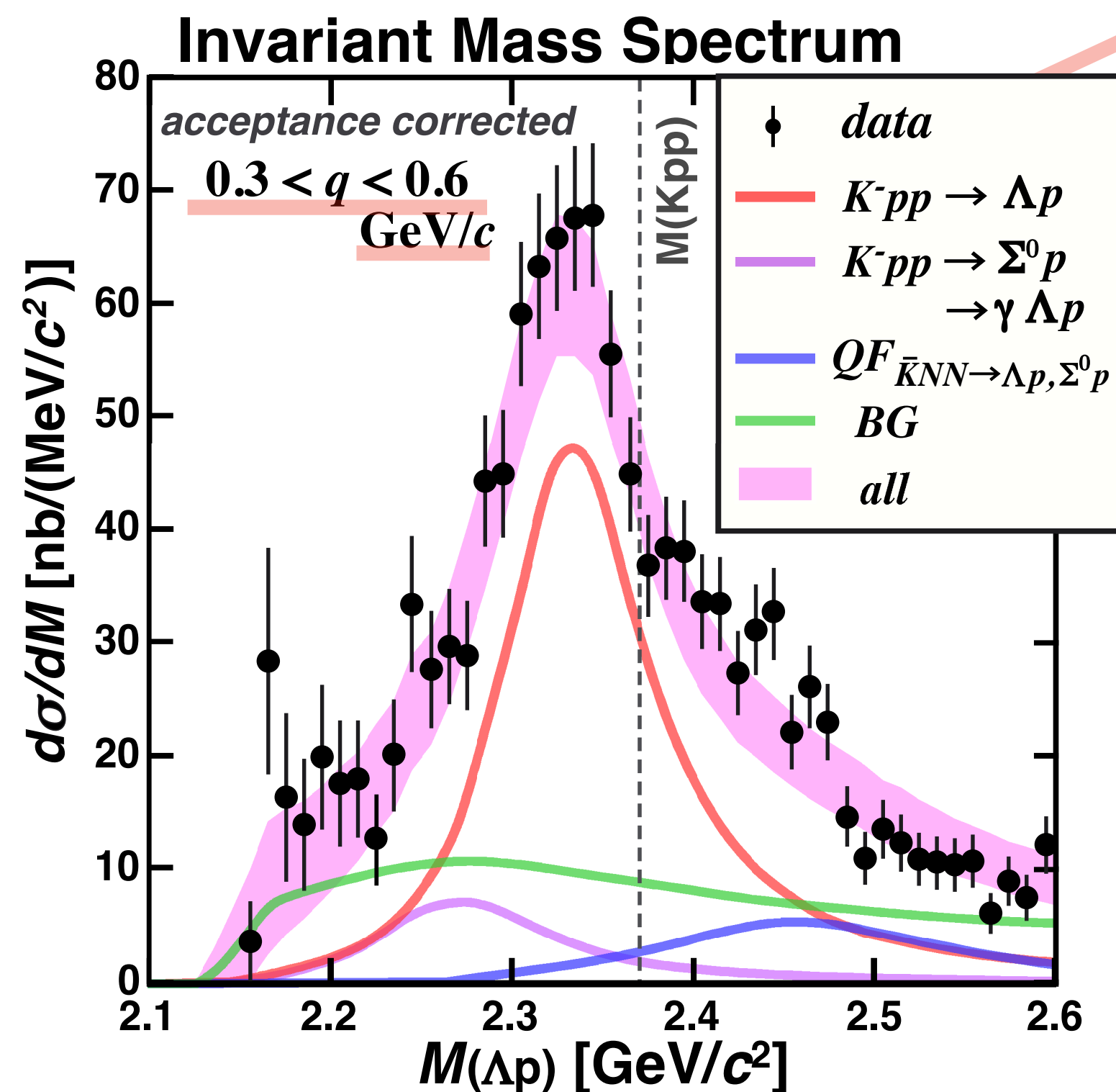

strong binding ($\bar{K}N$ attraction)

$$B_{Kpp} \sim 40 \text{ MeV}, \quad \Gamma_{Kpp} \sim 100 \text{ MeV}$$

PWIA based interpretation

— from time integral — — from space integral —

B.W. / Lorentzian

Gaussian form factor / structure factor

(plane wave impulse approximation)

$$\sigma(M, q) \propto$$

$$\rho_{3B}(M, q) \times$$

Differential cross section

Lorentz invariant phase space (Λp)

$$\frac{(\Gamma_{Kpp}/2)^2}{(M - M_{Kpp})^2 + (\Gamma_{Kpp}/2)^2}$$

$$\times \exp\left(-\frac{q^2}{Q_{Kpp}^2}\right)$$

Fourier Transformation of S-wave Harmonic Oscillator (HO)
— from spatial integral —

Invariant Mass Spectrum

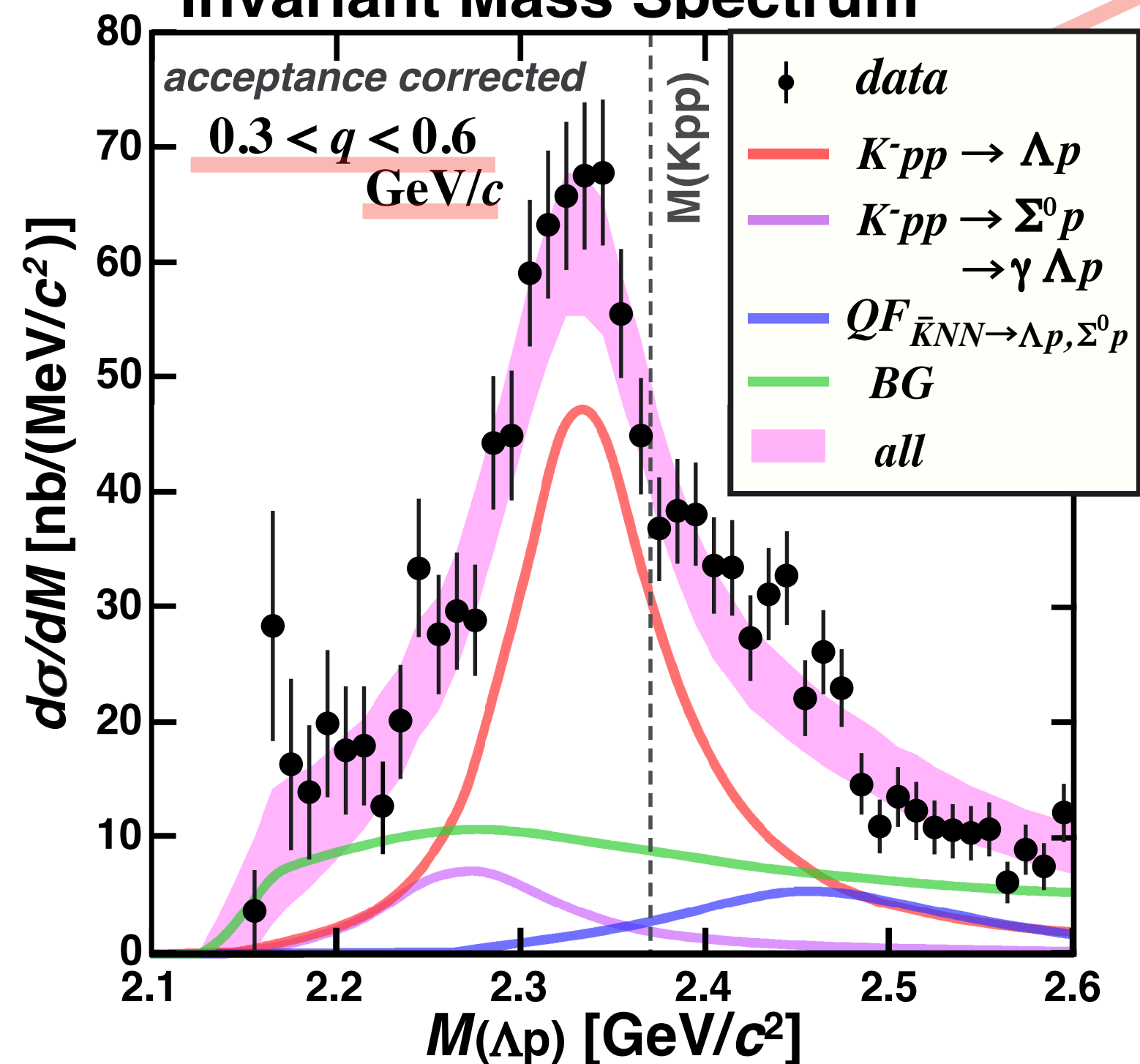

Momentum Transfer Spectrum

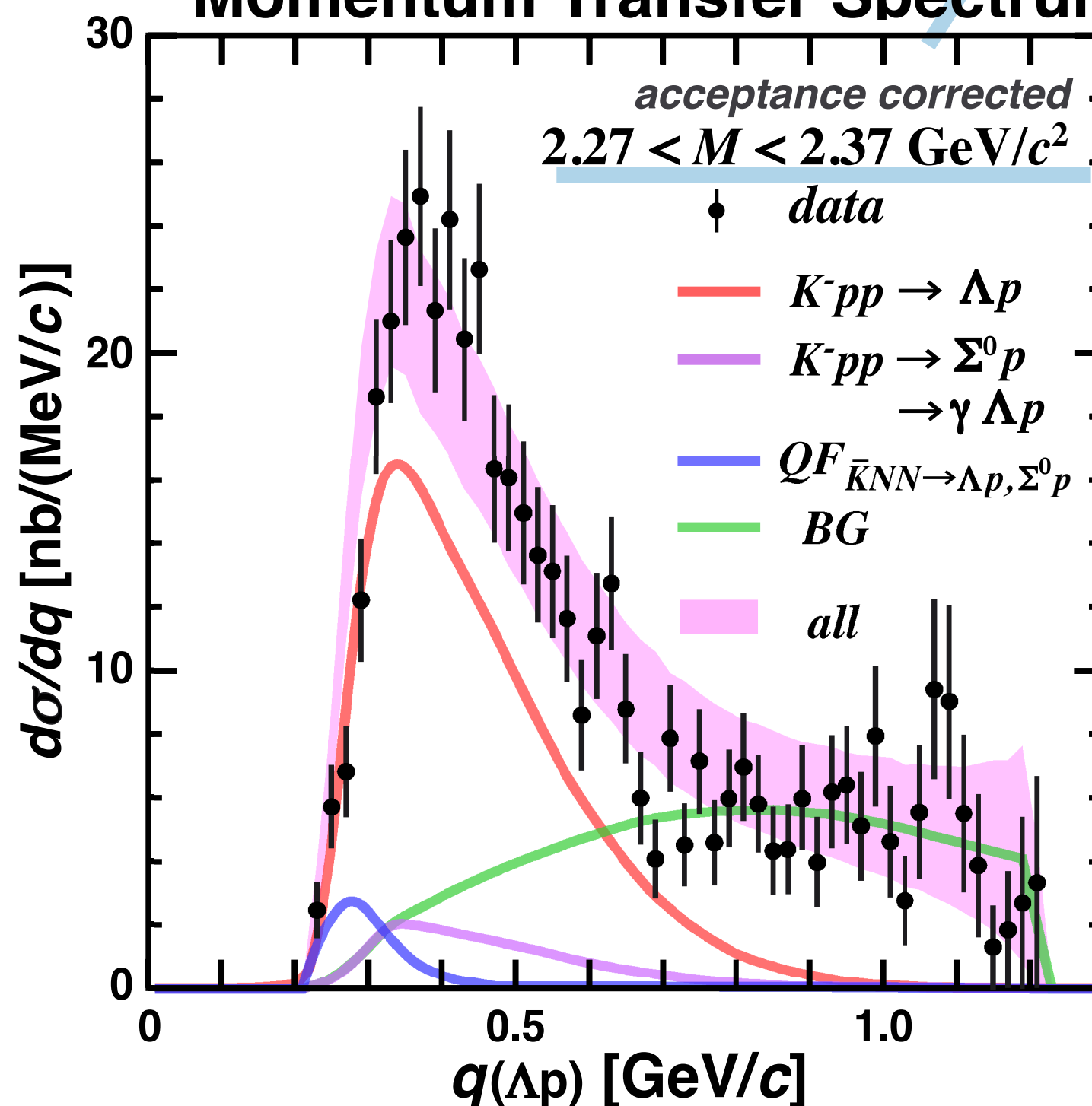

strong binding ($\bar{K}N$ attraction)

$$B_{Kpp} \sim 40 \text{ MeV}, \quad \Gamma_{Kpp} \sim 100 \text{ MeV}$$

wide momentum width

$$Q_{Kpp} \sim 400 \text{ MeV/c}$$

PWIA based interpretation

— from time integral — — from space integral —

B.W. / Lorentzian

Gaussian form factor / structure factor

(plane wave impulse approximation)

$$\sigma(M, q) \propto$$

$$\rho_{3B}(M, q) \times$$

Differential cross section

Lorentz invariant phase space (Λp)

$$\frac{(\Gamma_{Kpp}/2)^2}{(M - M_{Kpp})^2 + (\Gamma_{Kpp}/2)^2}$$

$$\times \exp\left(-\frac{q^2}{Q_{Kpp}^2}\right)$$

Fourier Transformation of S-wave Harmonic Oscillator (HO)
— from spatial integral —

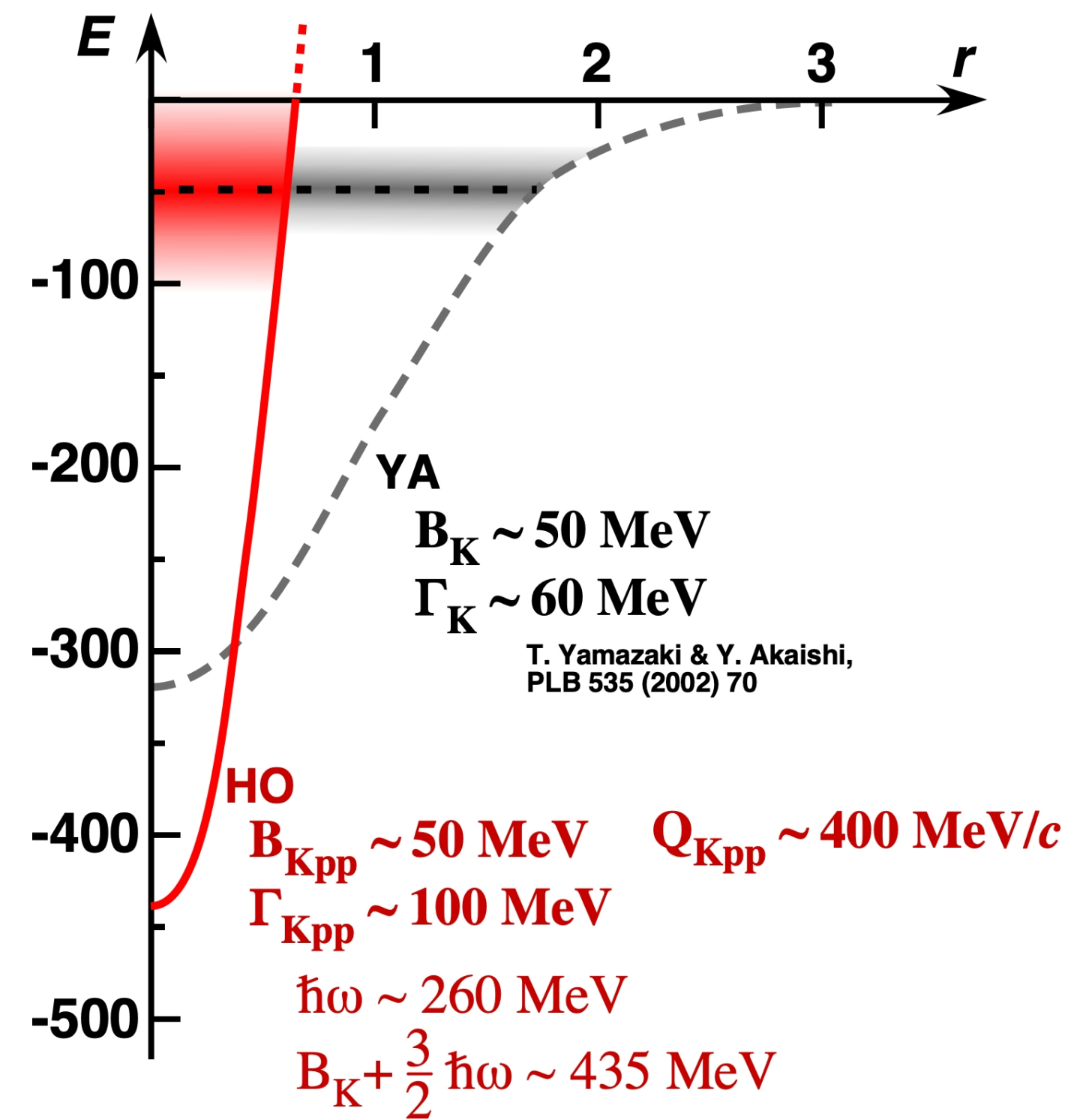
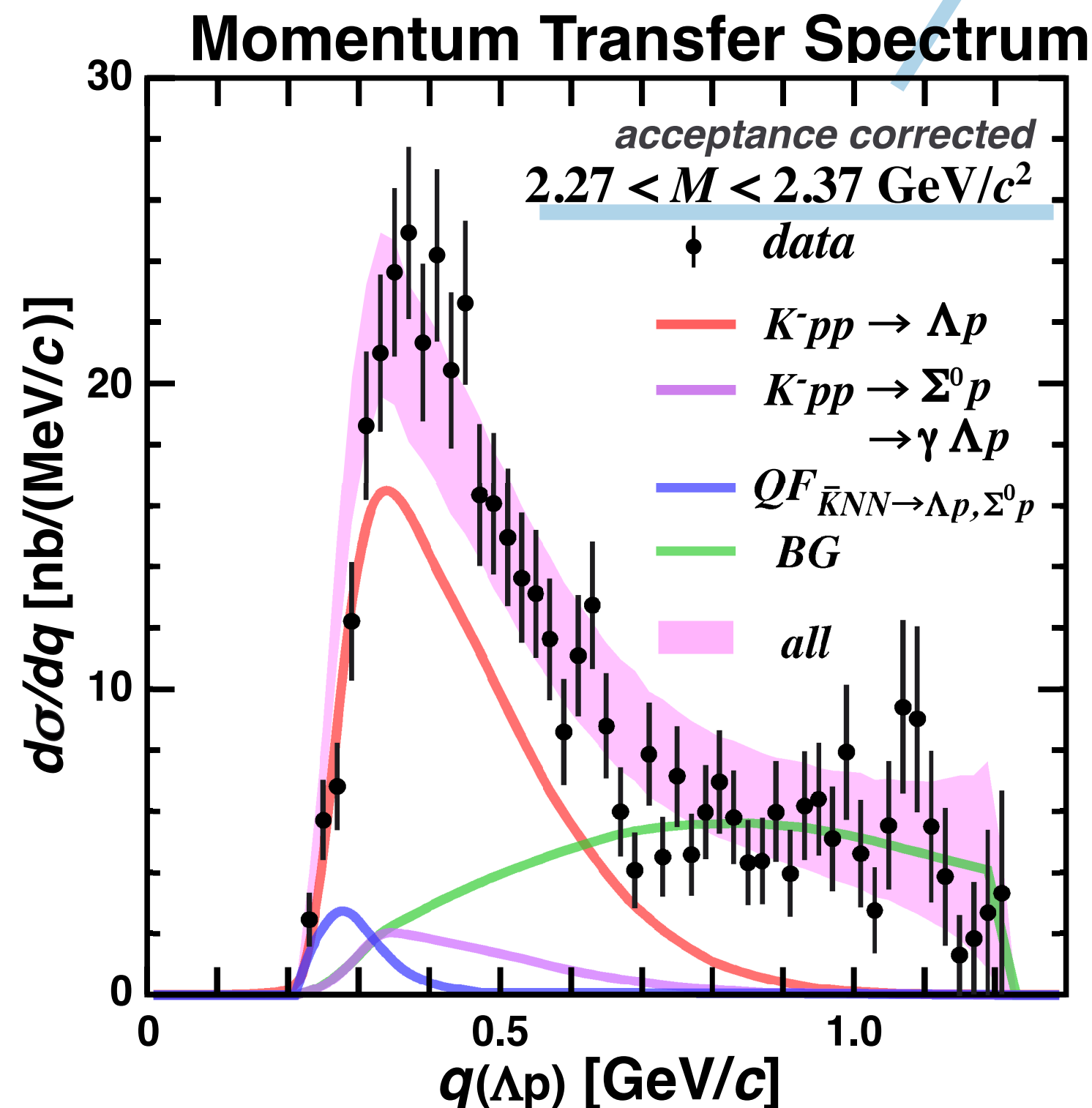
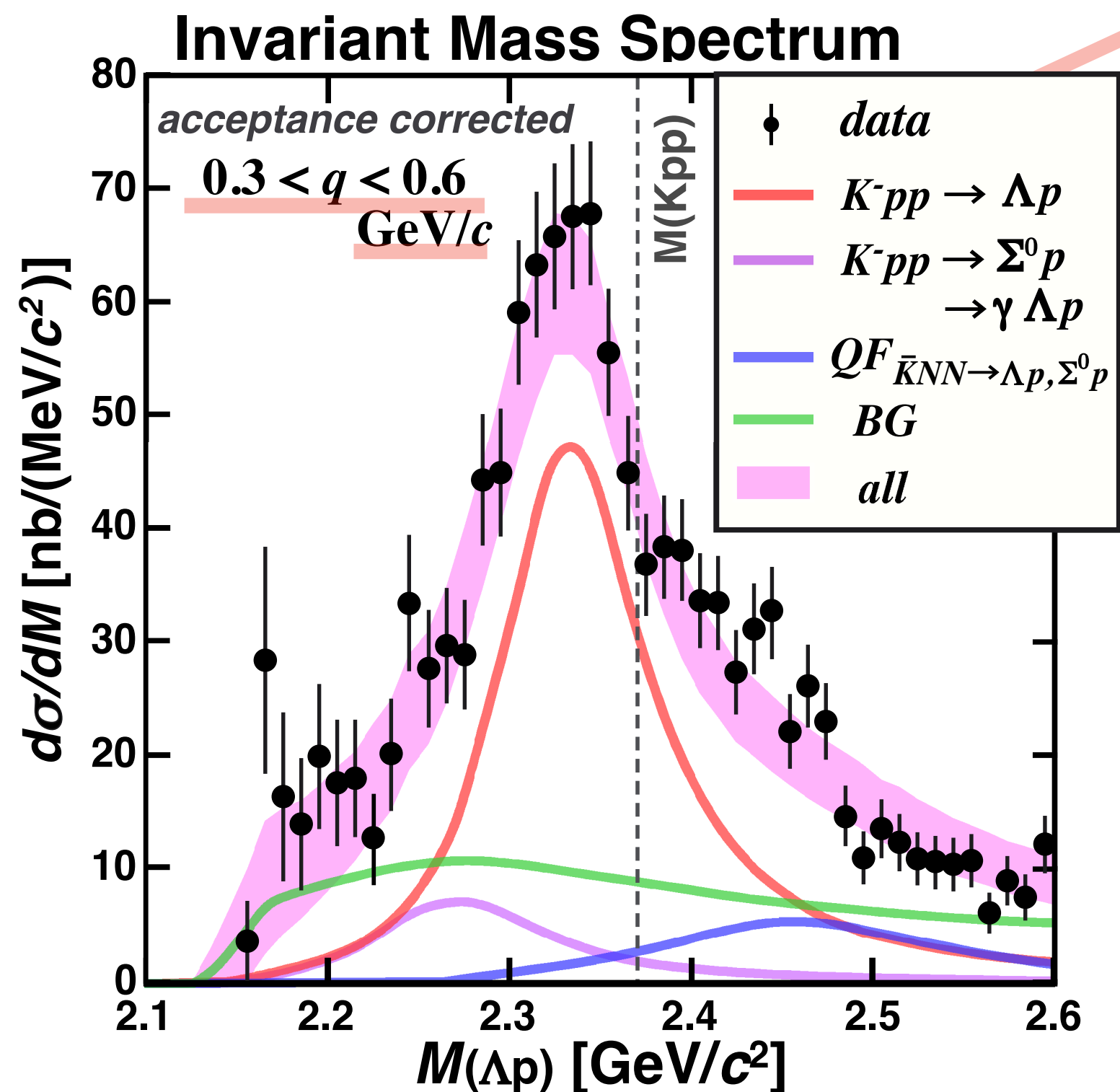

strong binding ($\bar{K}N$ attraction)

wide momentum width

... could be quite compact ...

$$B_{Kpp} \sim 40 \text{ MeV}, \quad \Gamma_{Kpp} \sim 100 \text{ MeV}$$

$$Q_{Kpp} \sim 400 \text{ MeV}/c$$

$$(R_{Kpp} \sim 0.6 \text{ fm (H.O.)})$$

Mesonic Decay Modes of $\bar{K}NN$

- Mesonic decays will give us further information on $\bar{K}NN$
 - ✓ internal structure
 - ✓ $\bar{K}N$ interaction below the threshold

Mesonic

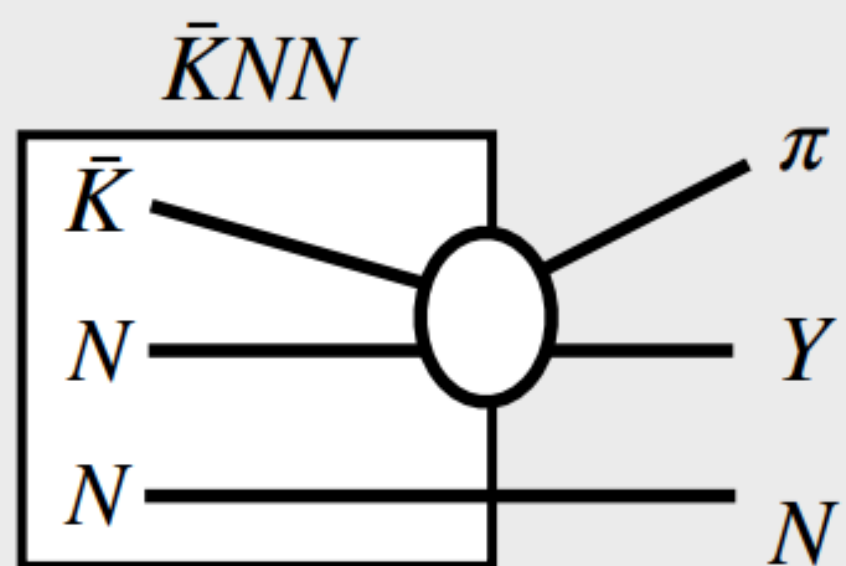

1N absorption

Non-mesonic

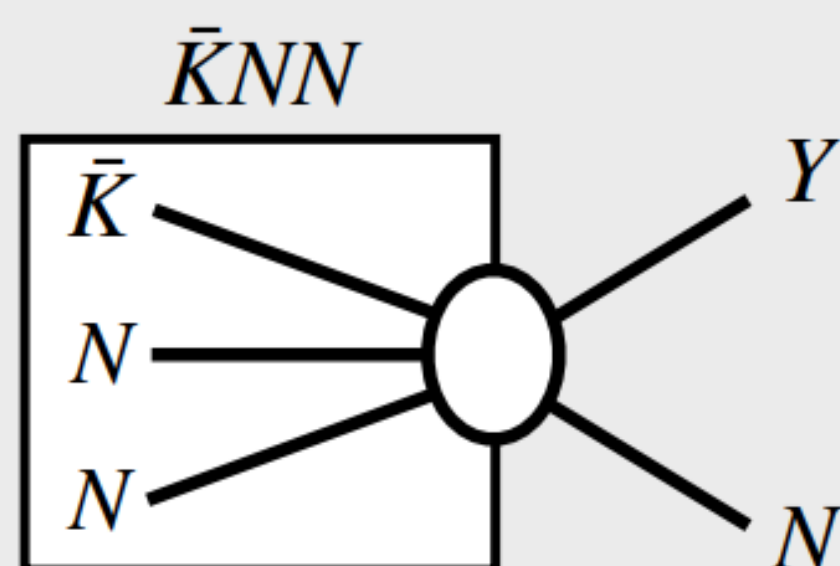

2N absorption

Mesonic Decay Modes of $\bar{K}NN$

- Mesonic decays will give us further information on $\bar{K}NN$
 - ✓ internal structure
 - ✓ $\bar{K}N$ interaction below the threshold

S. Ohnishi, et al.,
Phys. Rev. C 88 (2013) 025204.

$$\Gamma_{YN} \ll \Gamma_{\pi YN}$$

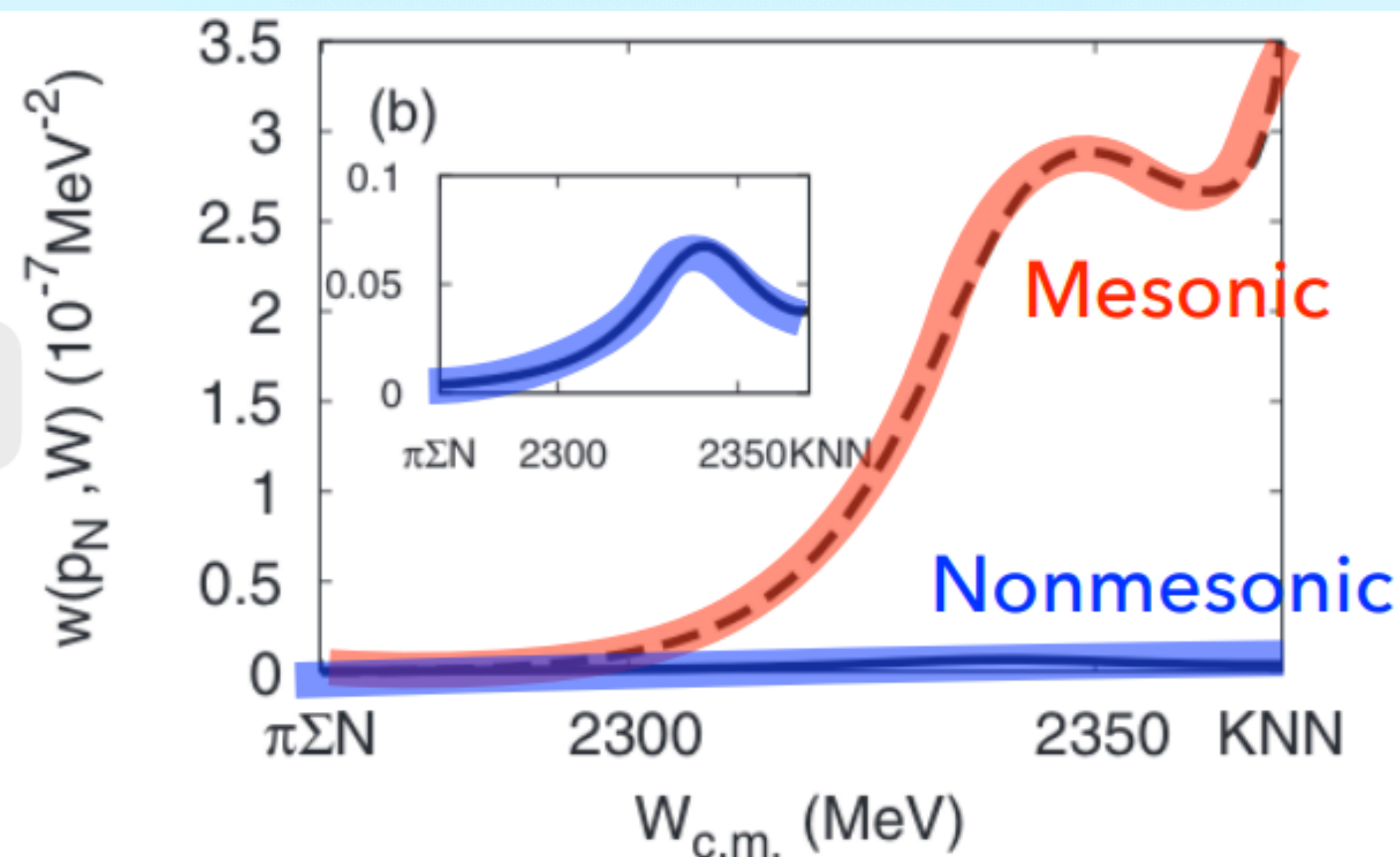

Mesonic

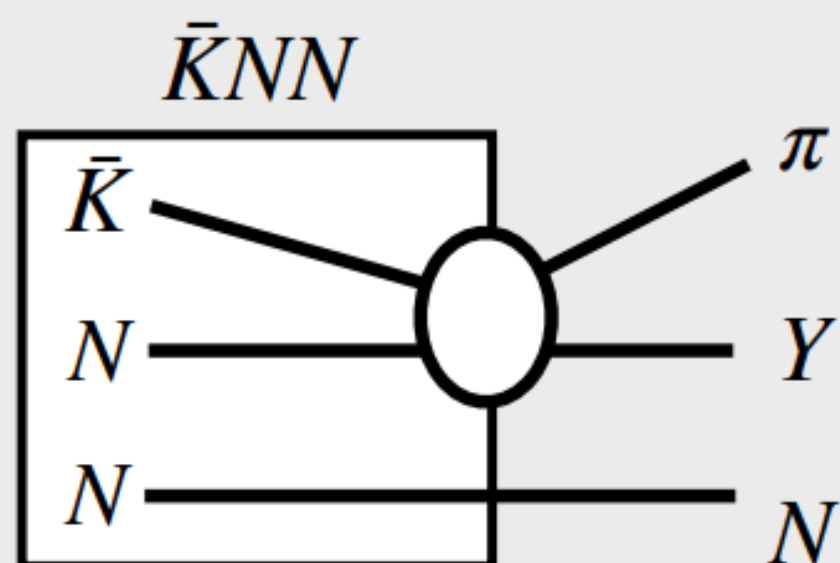

1N absorption

Non-mesonic

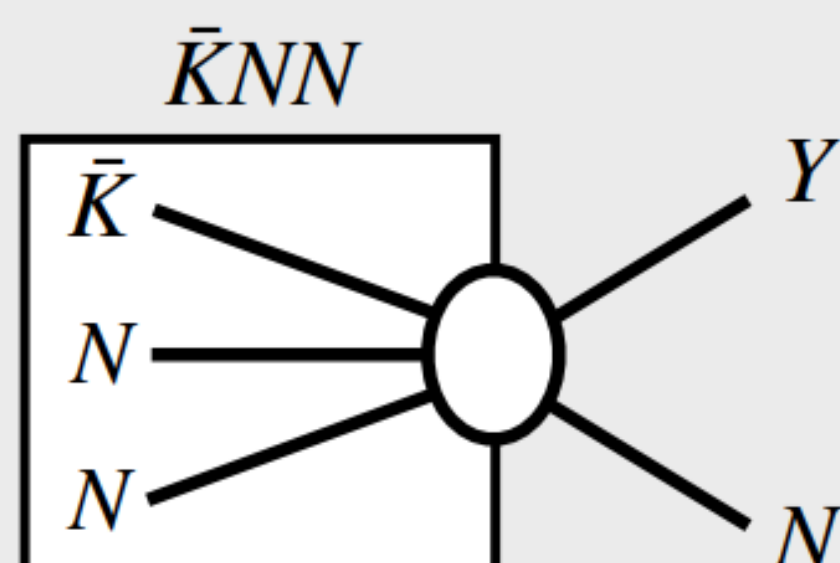

2N absorption

Mesonic Decay Modes of $\bar{K}NN$

- Mesonic decays will give us further information on $\bar{K}NN$
 - ✓ internal structure
 - ✓ $\bar{K}N$ interaction below the threshold

S. Ohnishi, et al.,
Phys. Rev. C 88 (2013) 025204.

$$\Gamma_{YN} \ll \Gamma_{\pi YN}$$

40 times??

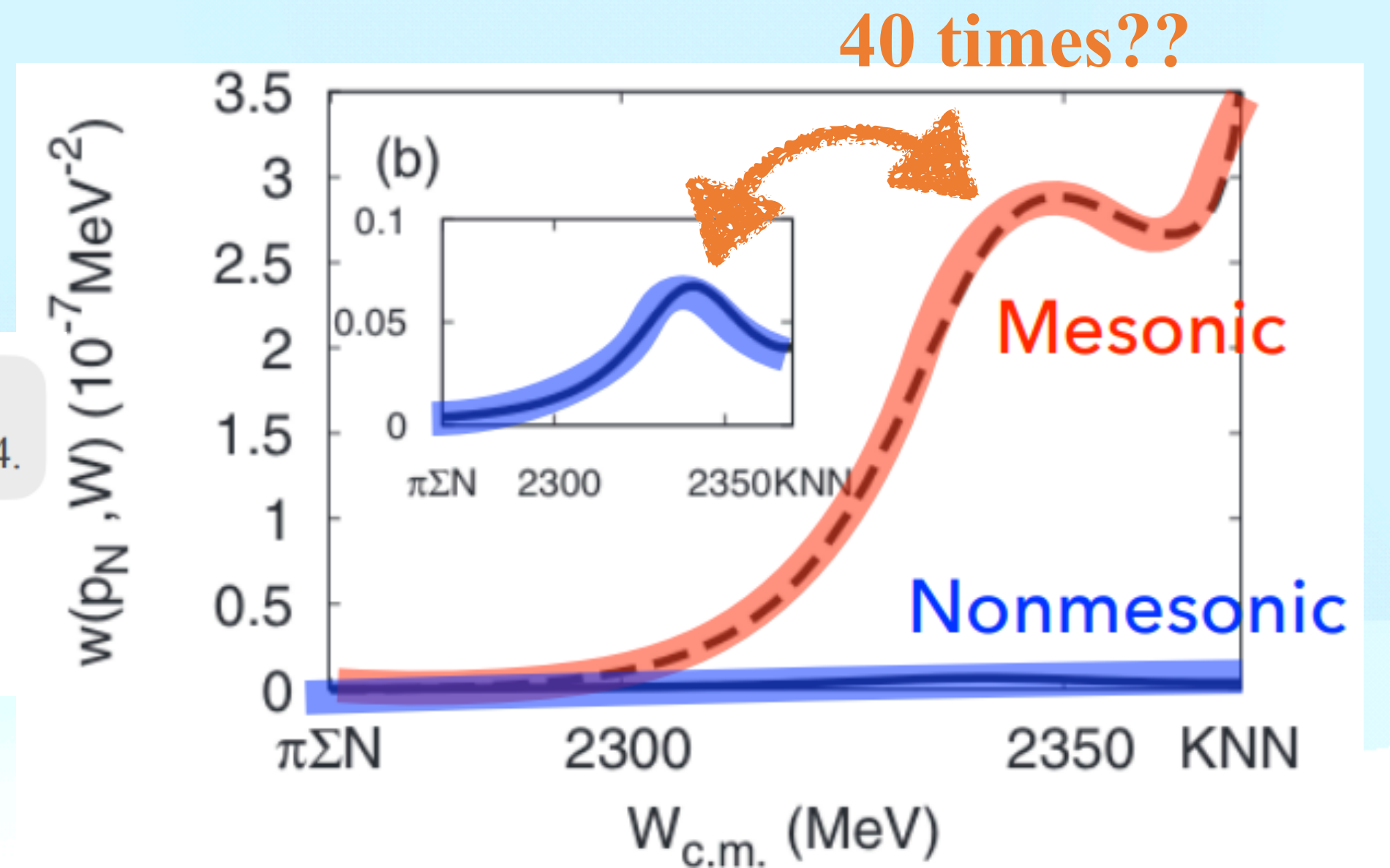

Mesonic

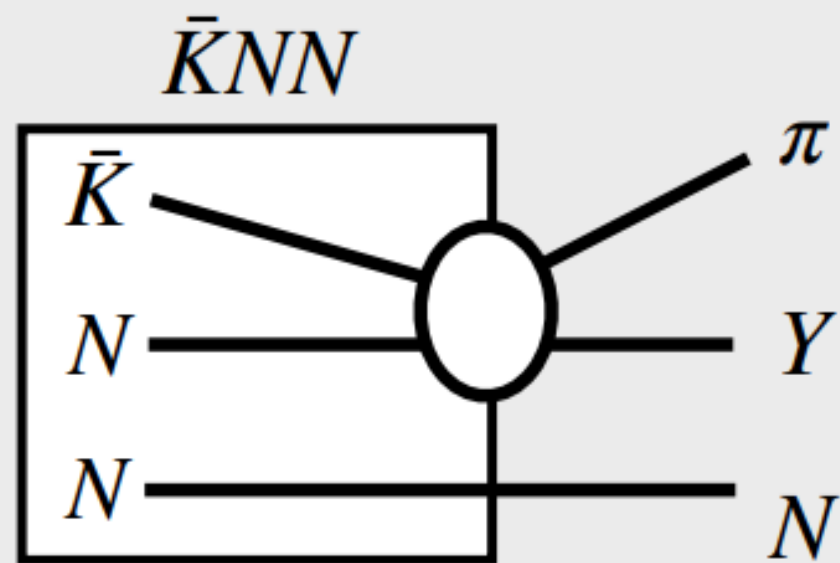

1N absorption

Non-mesonic

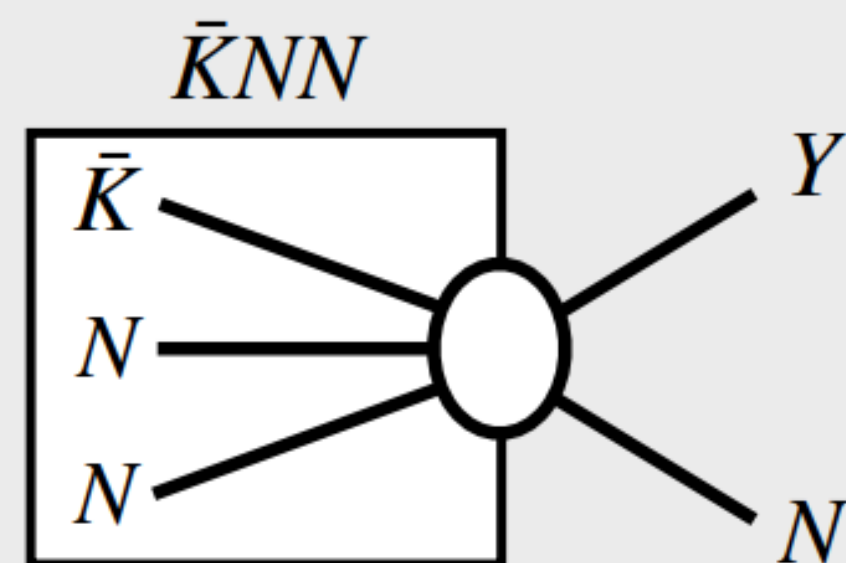

2N absorption

Mesonic Decay Modes of $\bar{K}NN$

- Mesonic decays will give us further information on $\bar{K}NN$
 - ✓ internal structure
 - ✓ $\bar{K}N$ interaction below the threshold
 - ✓ density of the state

S. Ohnishi, et al.,
Phys. Rev. C 88 (2013) 025204.

$$\Gamma_{YN} \ll \Gamma_{\pi YN}$$

40 times??

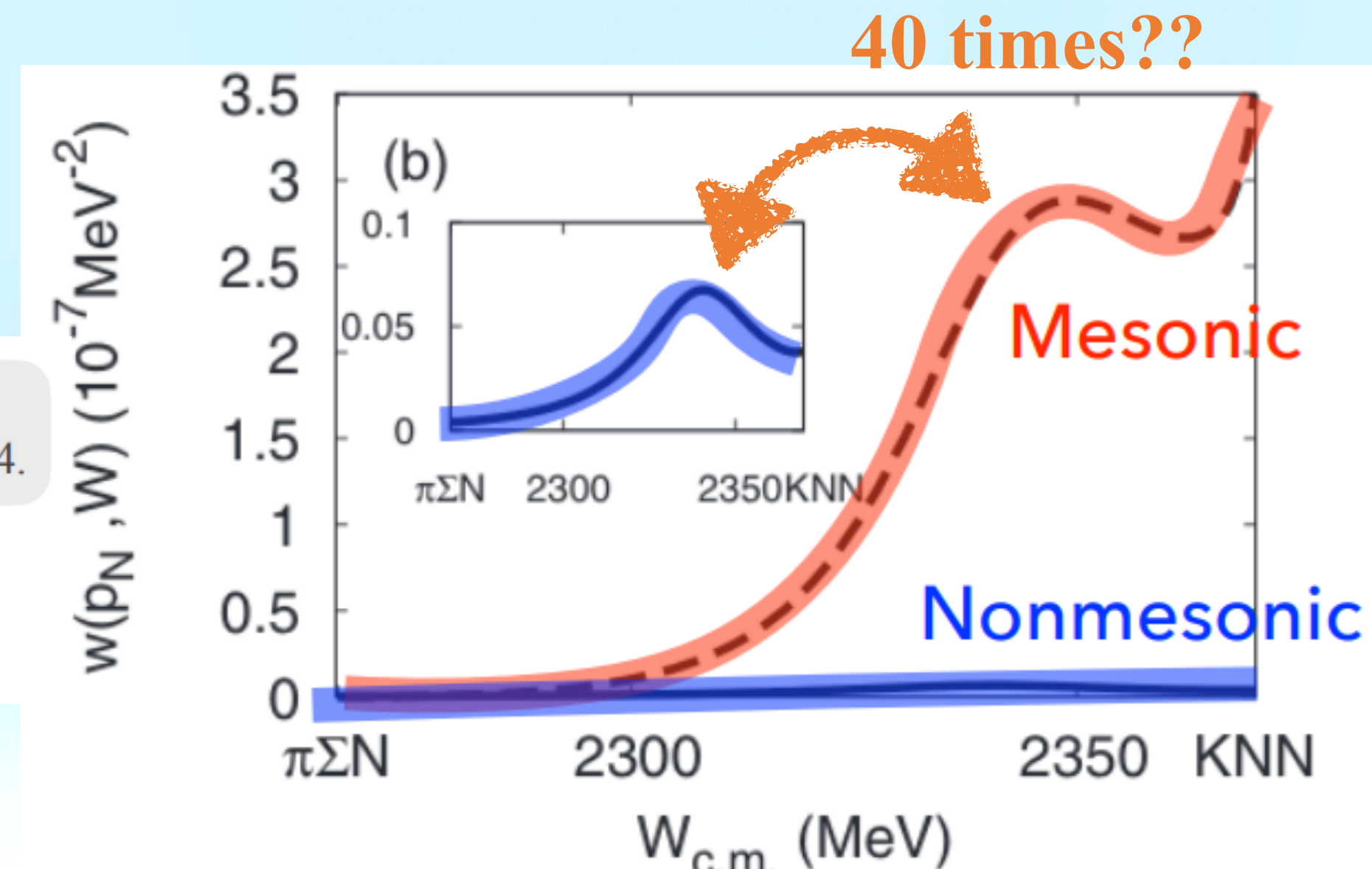

Mesonic

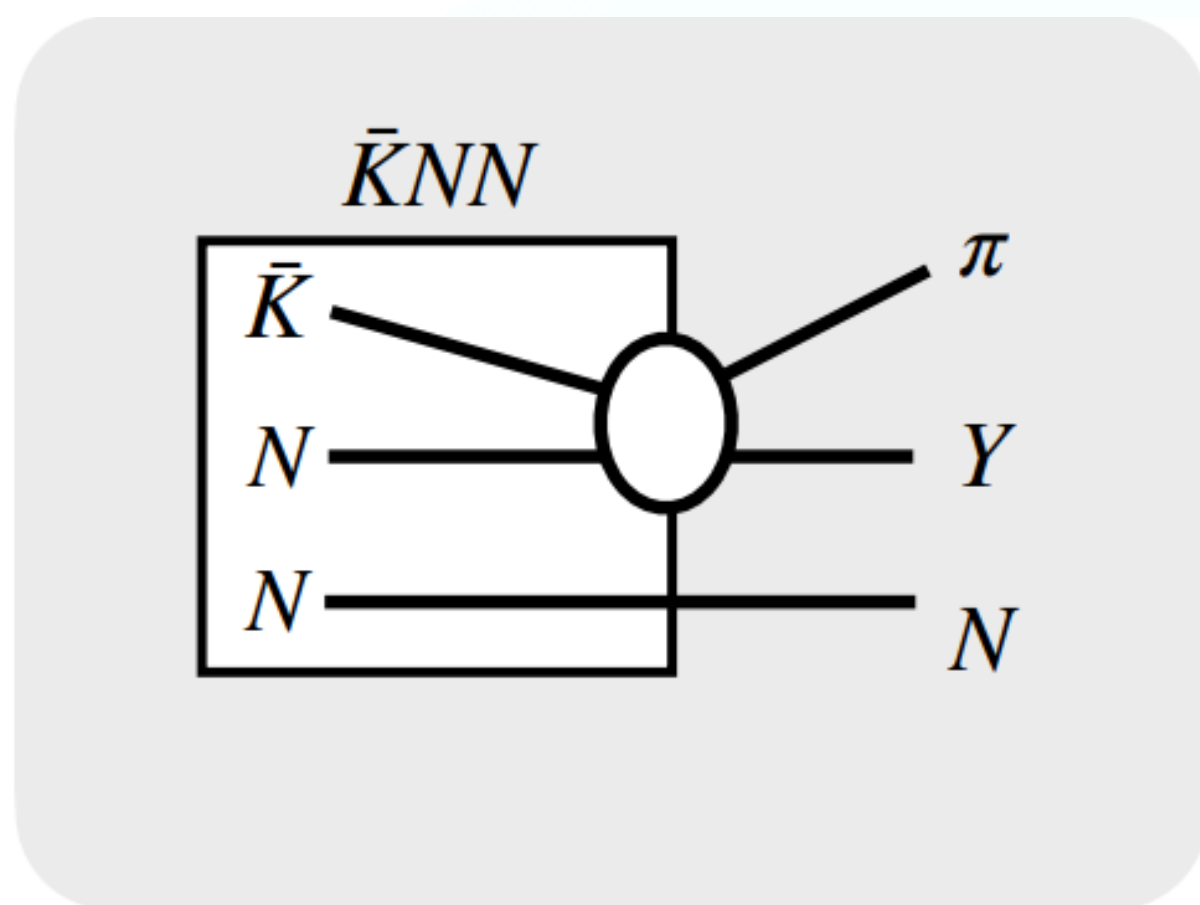

1N absorption

Non-mesonic

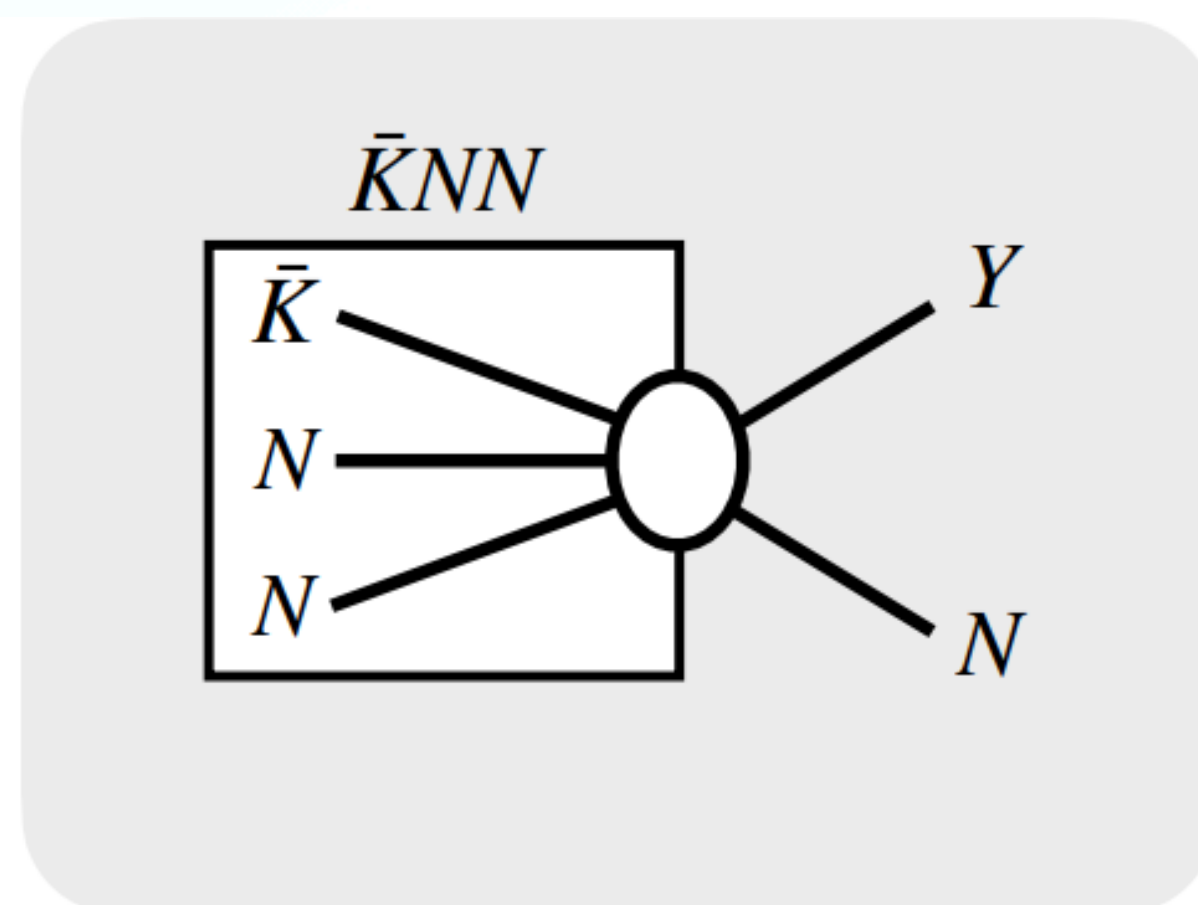

2N absorption

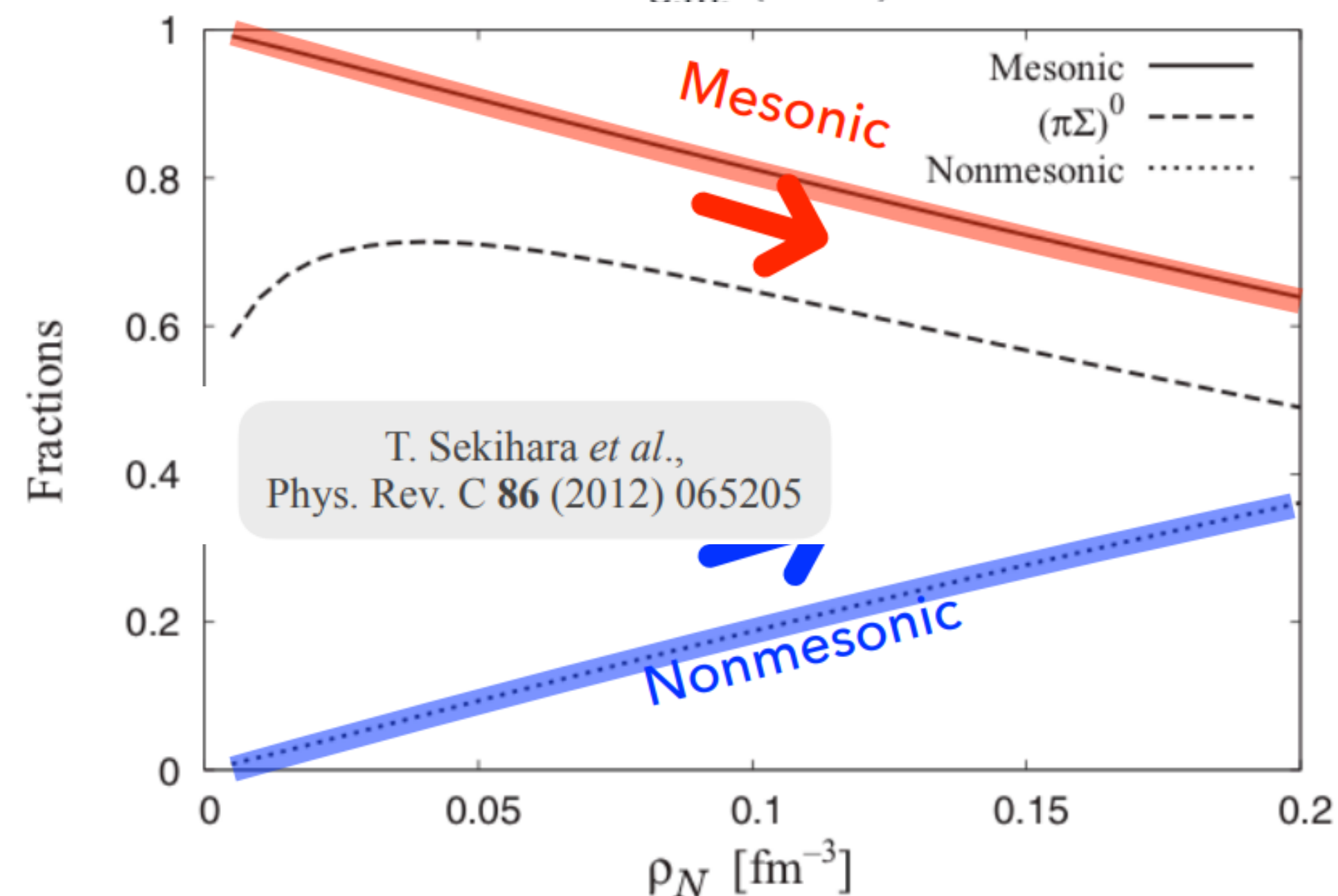

Mesonic Decay Analysis (with the E15 Data)

- with neutron detection using a thin scintillation counter array (CDH)
 - small efficiency (3~9%)
 - BG from the inner wall of the magnet

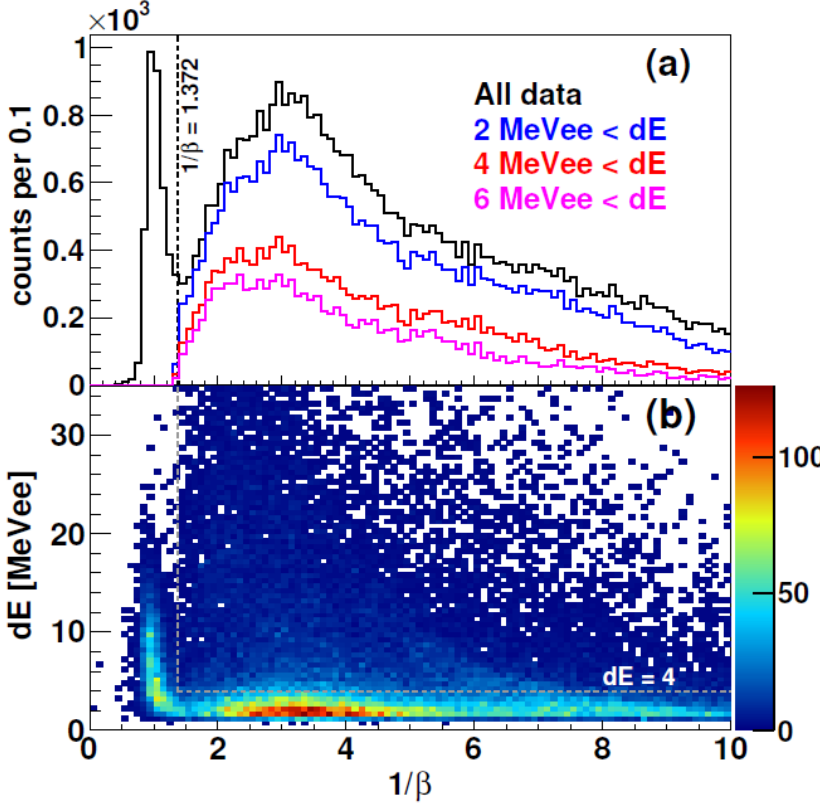
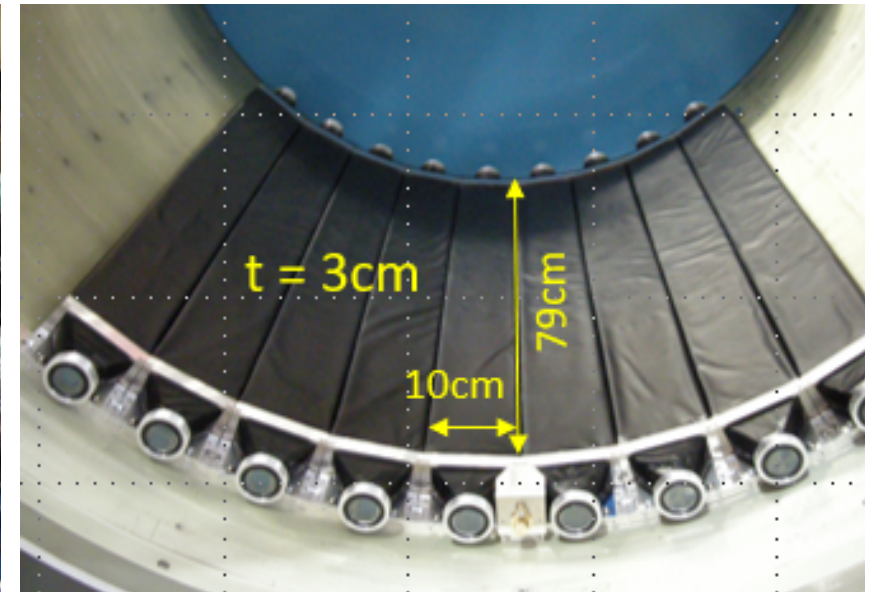
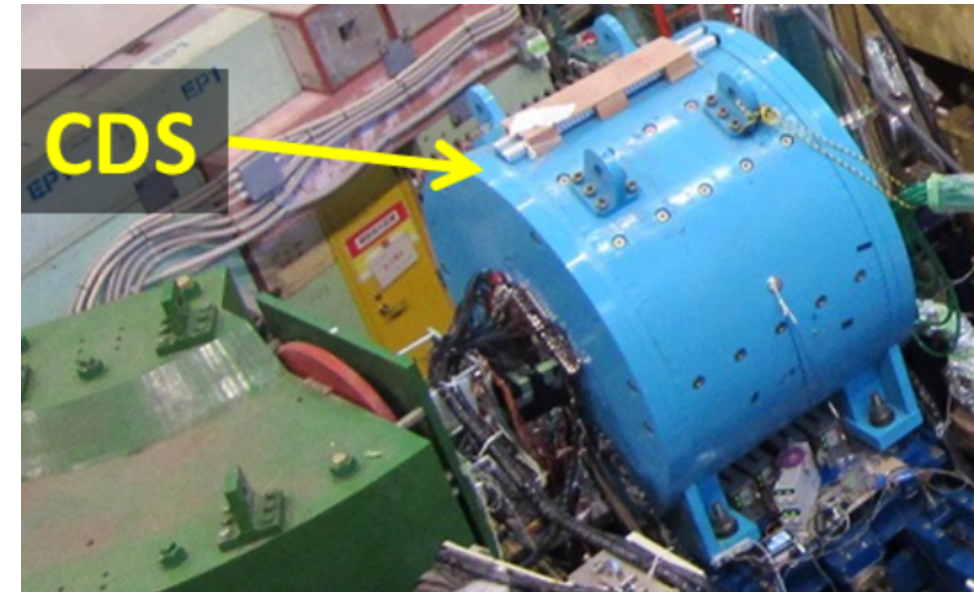

" K^-pp " \rightarrow Λp

" K^-pp " \rightarrow $\pi^\pm \Sigma^\mp p$

" K^-pp " \rightarrow $\pi^+ \Lambda n$

" $\bar{K}^0 nn$ " \rightarrow $\pi^- \Lambda p$

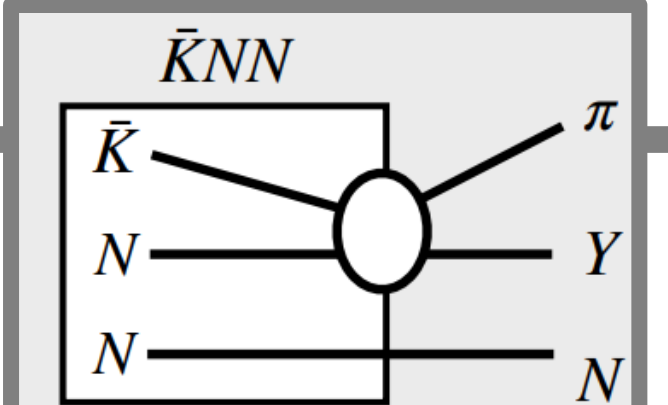
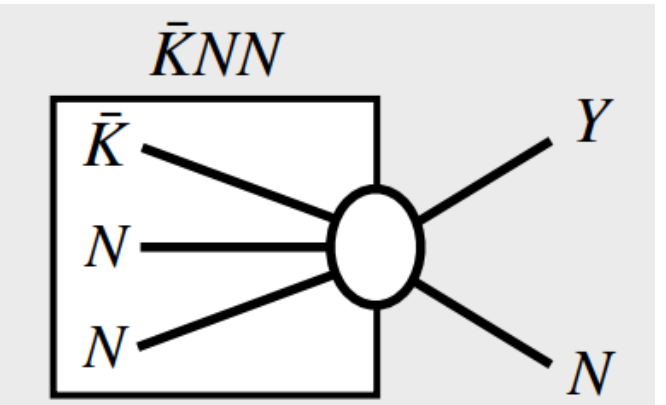
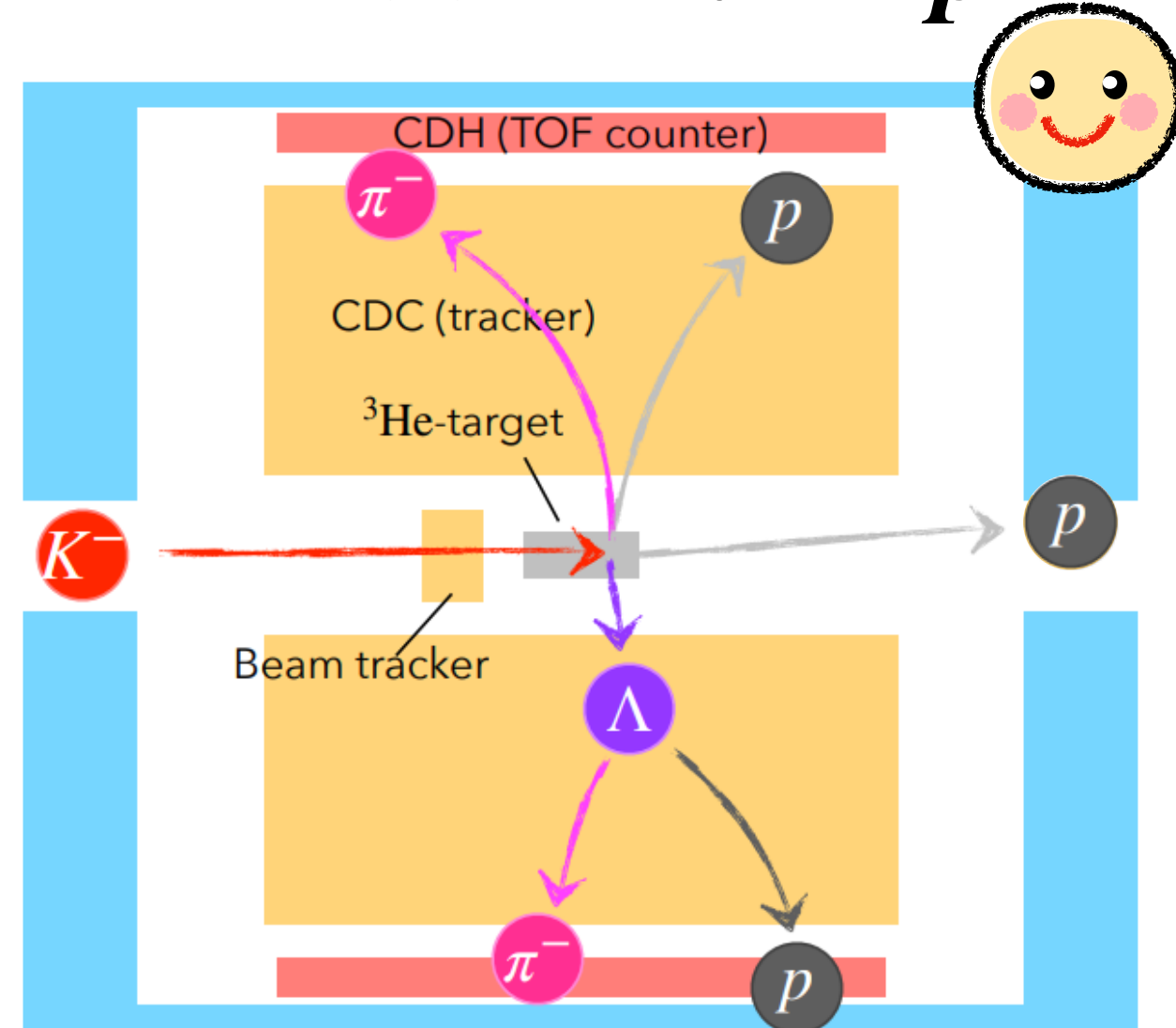
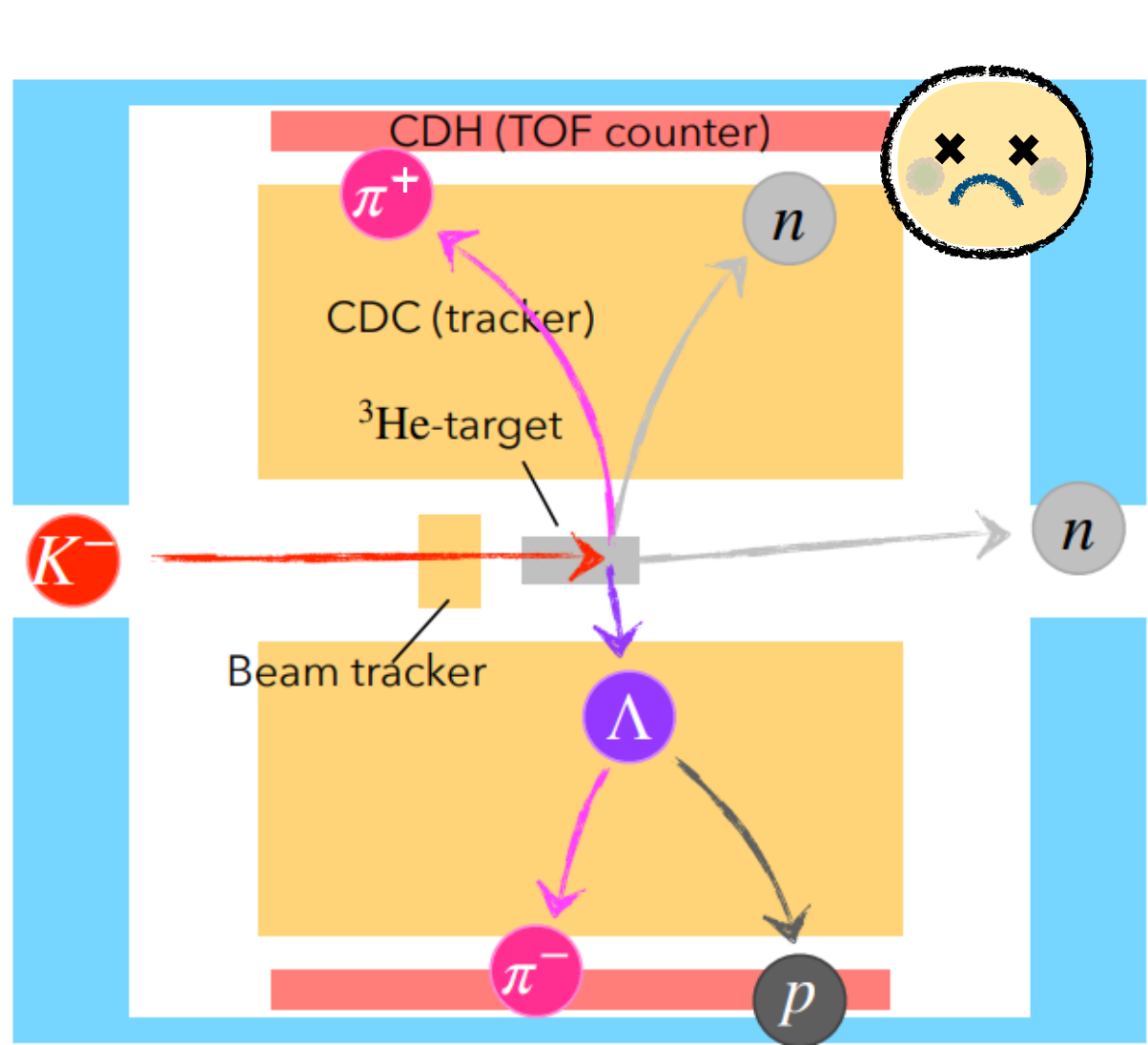
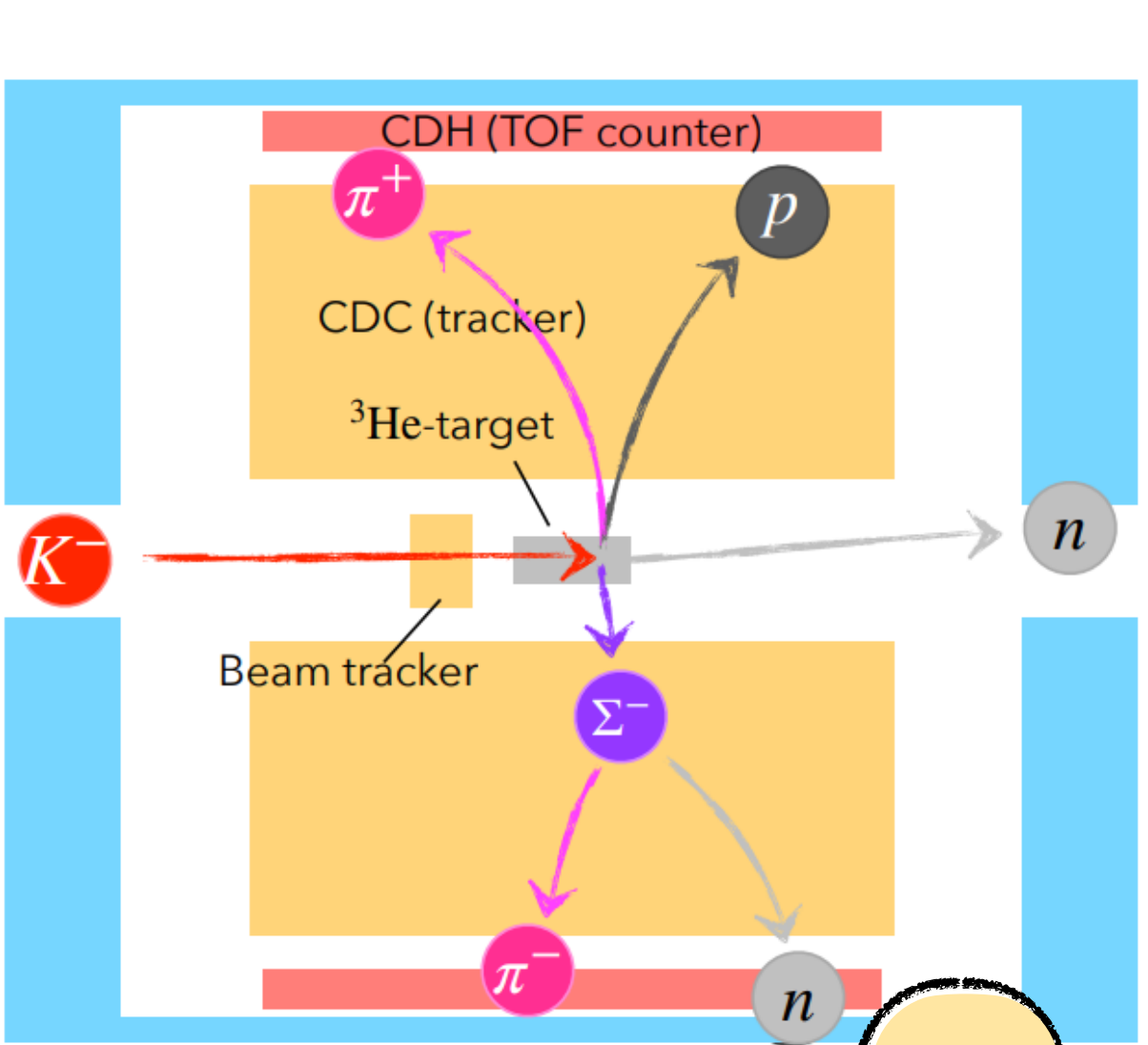
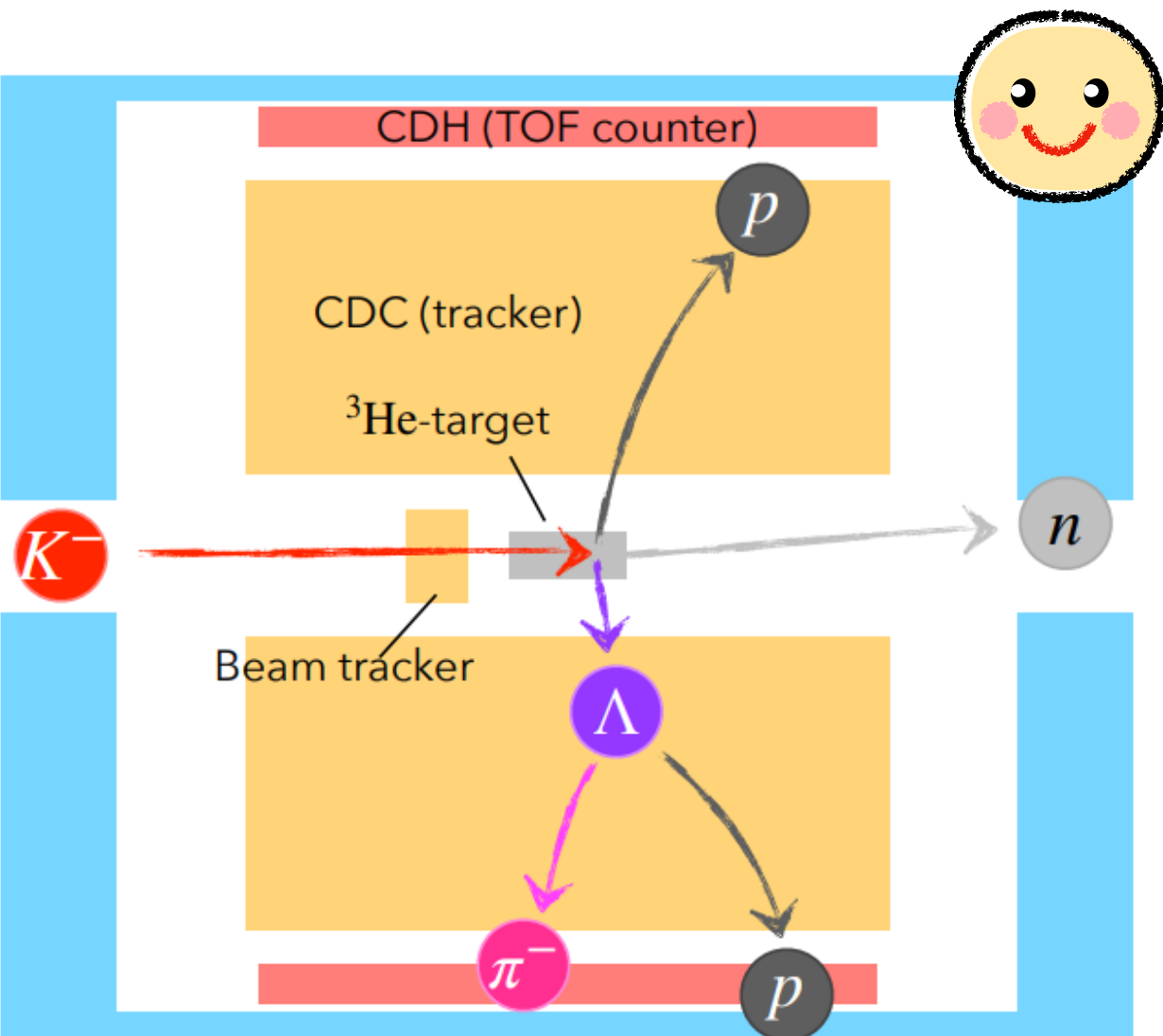

Plane Wave Impulse Approximation
Fit with PWIA $\sigma(M, q) \propto \rho(M, q) \times \frac{(\Gamma_{Kpp}/2)^2}{(M - M_{Kpp})^2 + (\Gamma_{Kpp}/2)^2} \times \exp\left(-\frac{q^2}{Q_{Kpp}^2}\right)$

Phase space (green box) Energy term (BW type) from time integral (red box) Momentum term from spatial integral (blue box)

" $K^-pp \rightarrow \Lambda p$ "

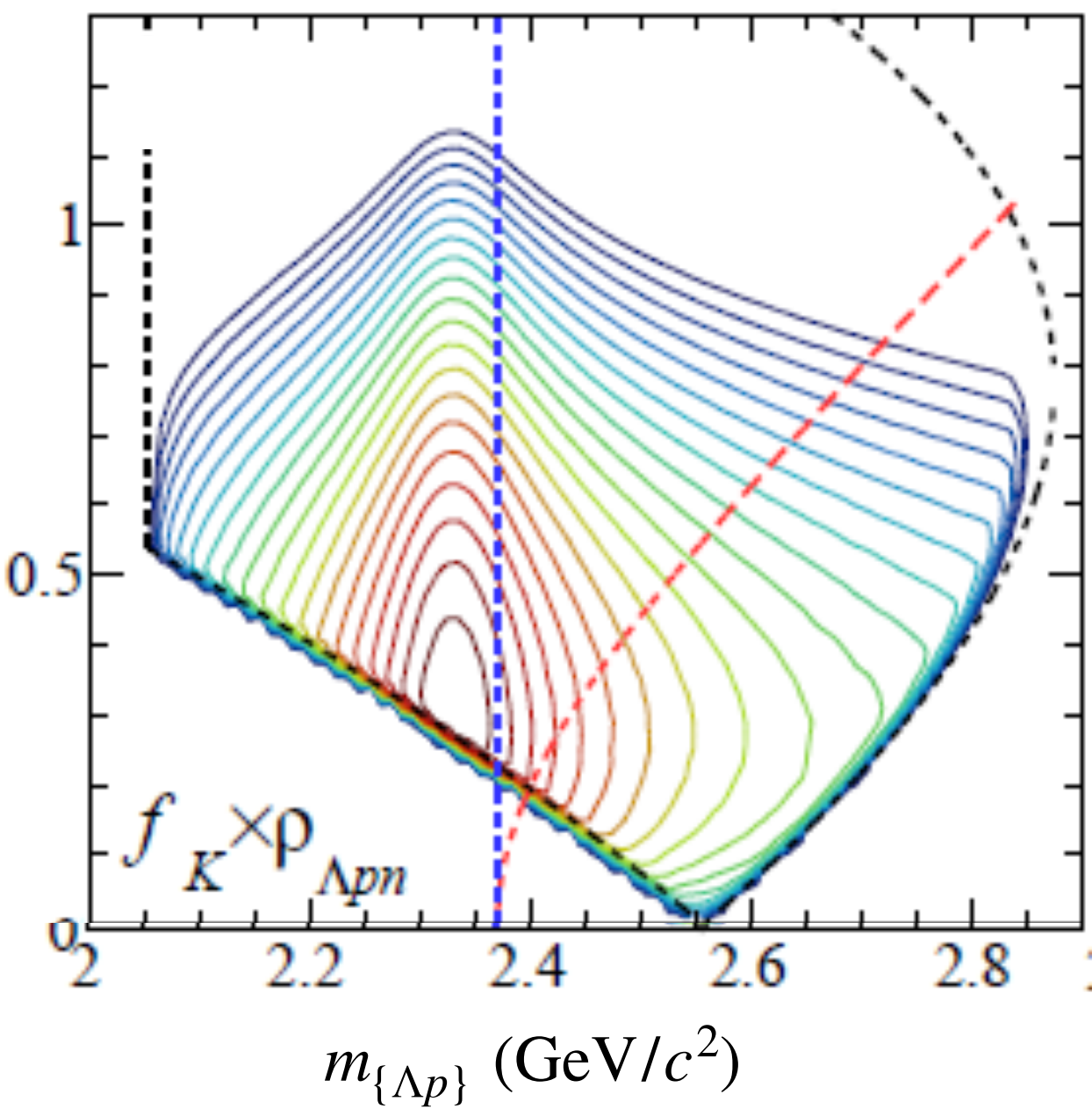

$m_{\{\pi^{\pm}\Sigma^{\mp}p\}}$ (GeV/c²)

$m_{\{\pi^+\Lambda n\}}$ (GeV/c²)

$m_{\{\pi^-\Lambda p\}}$ (GeV/c²)

Plane Wave Impulse Approximation
Fit with PWIA $\sigma(M, q) \propto \rho(M, q) \times \frac{(\Gamma_{Kpp}/2)^2}{(M - M_{Kpp})^2 + (\Gamma_{Kpp}/2)^2} \times \exp\left(-\frac{q^2}{Q_{Kpp}^2}\right)$

Phase space (green box) Energy term (BW type) from time integral (red box) Momentum term from spatial integral (blue box)

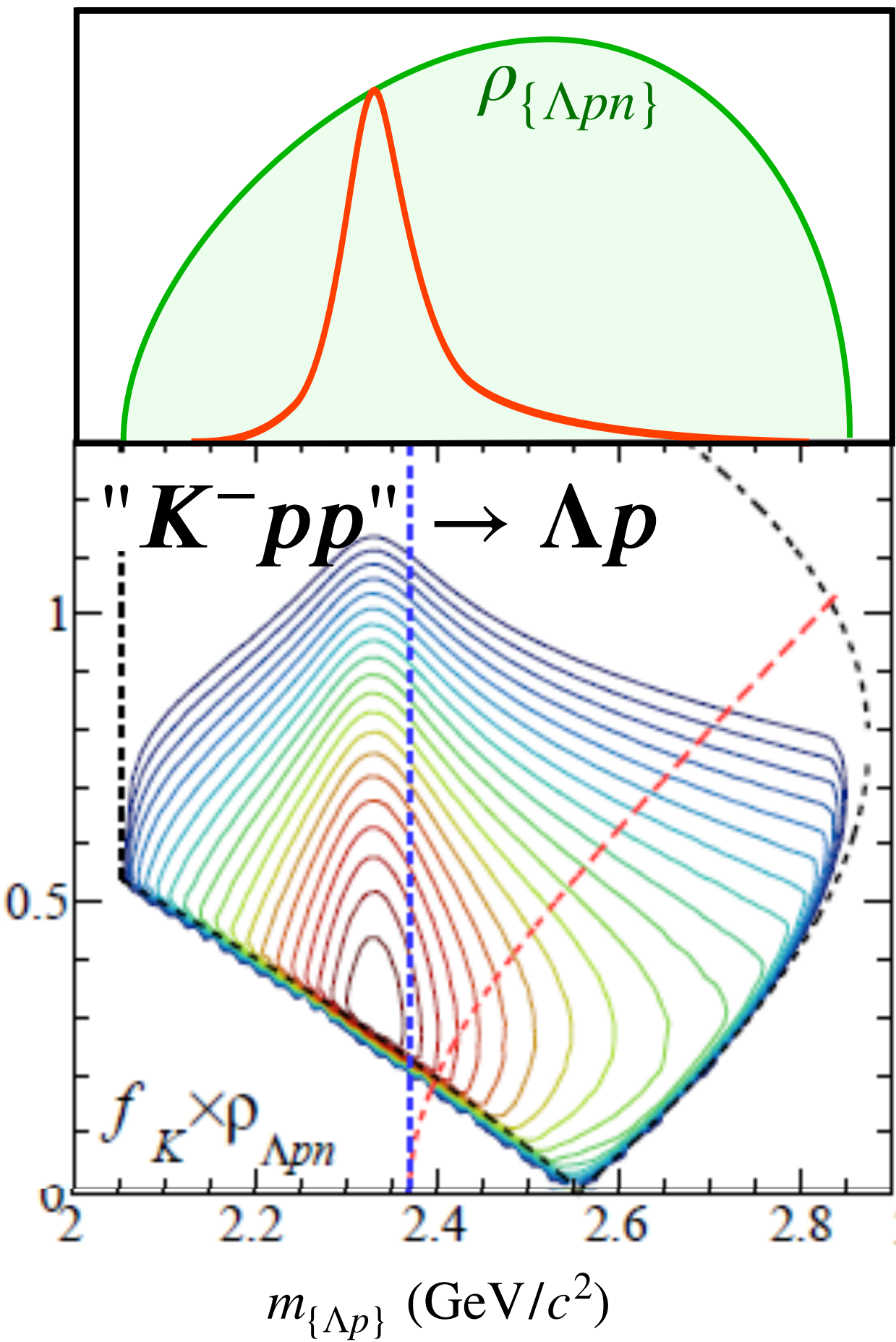

$m_{\{\pi^\pm \Sigma^\mp p\}}$ (GeV/c²)

$m_{\{\pi^+ \Lambda n\}}$ (GeV/c²)

$m_{\{\pi^- \Lambda p\}}$ (GeV/c²)

Plane Wave Impulse Approximation
Fit with PWIA $\sigma(M, q) \propto \rho(M, q) \times \frac{(\Gamma_{Kpp}/2)^2}{(M - M_{Kpp})^2 + (\Gamma_{Kpp}/2)^2} \times \exp\left(-\frac{q^2}{Q_{Kpp}^2}\right)$

Phase space Momentum term from spatial integral
Energy term (BW type) from time integral

Mass spectra are expected to be modified substantially, due to Phase Space!

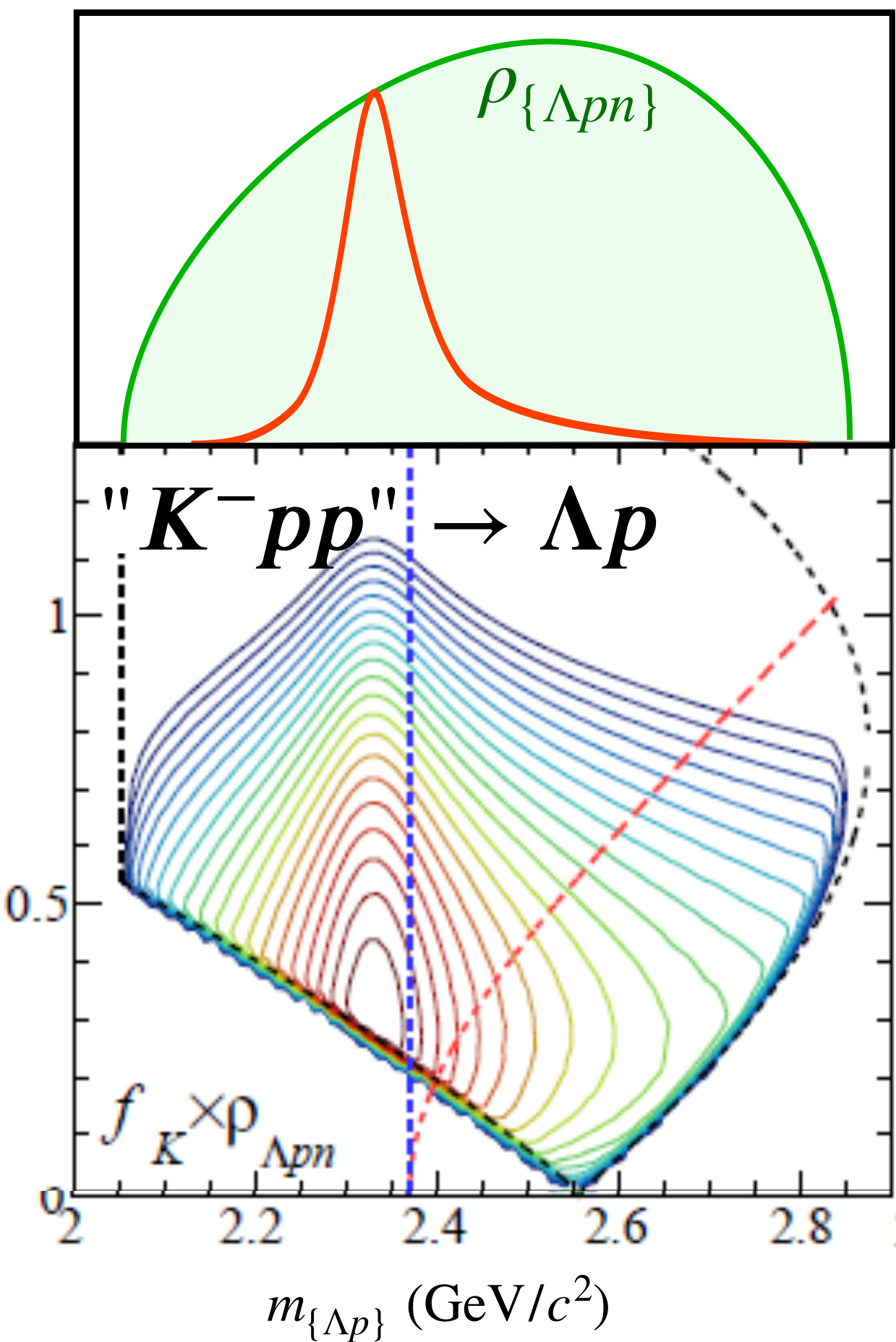

Mass spectra are expected to be modified substantially, due to *Phase Space*!

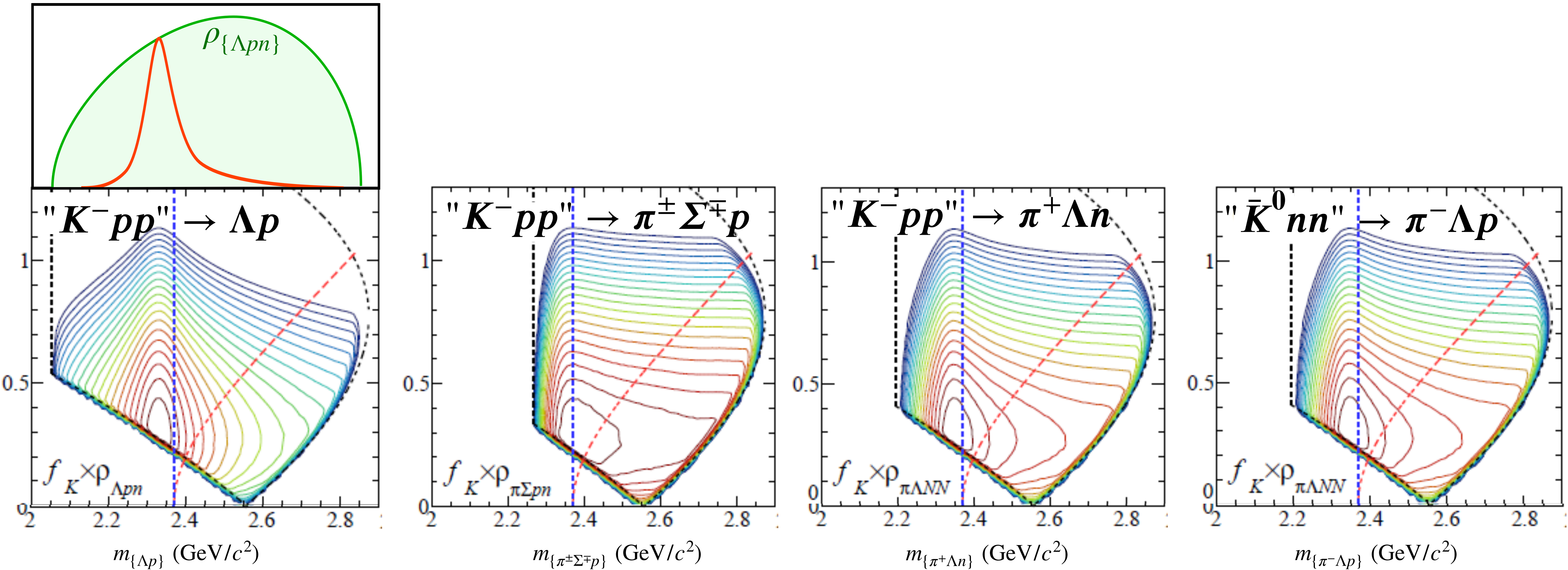

Mass spectra are expected to be modified substantially, due to *Phase Space*!

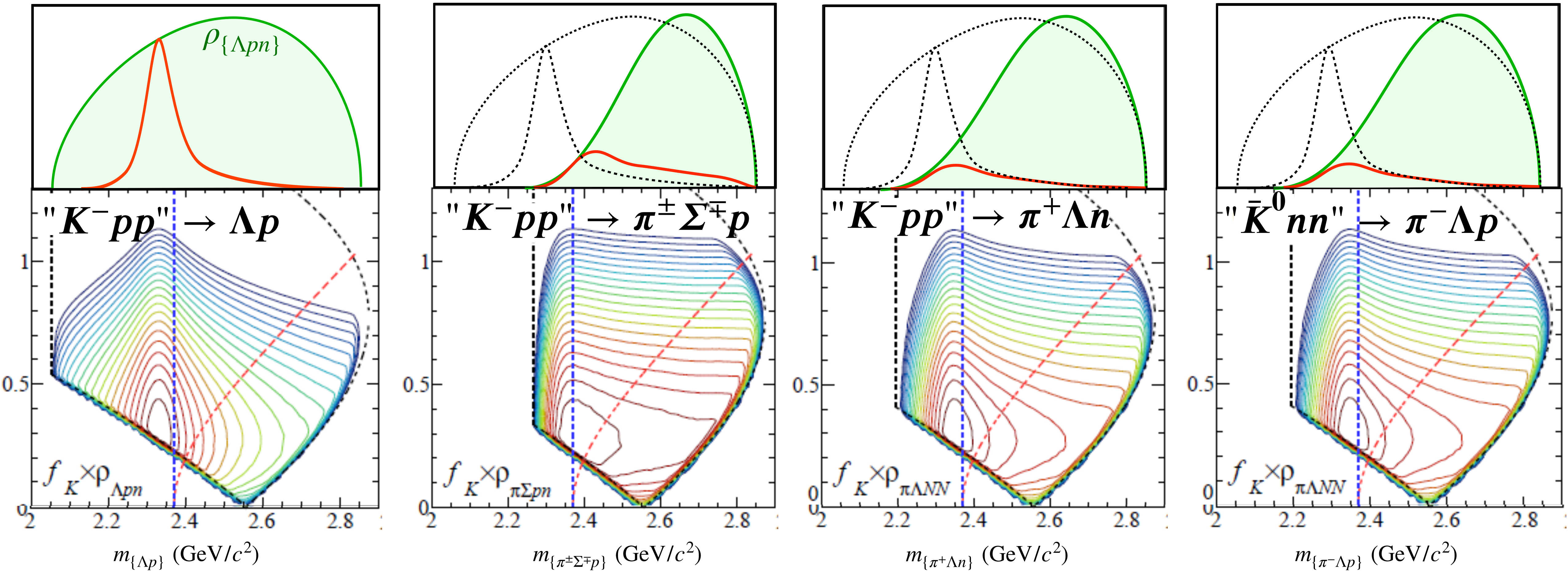

Mass spectra are expected to be modified substantially, due to *Phase Space*!

1) mass threshold $m_{\{\pi\Lambda p\}} \in [m_{\Lambda} + m_p, E_{\{K^3\text{He}\}}^* - m_n] \rightarrow [m_{\pi} + m_Y + m_N, E_{\{K^3\text{He}\}}^* - m_N]$

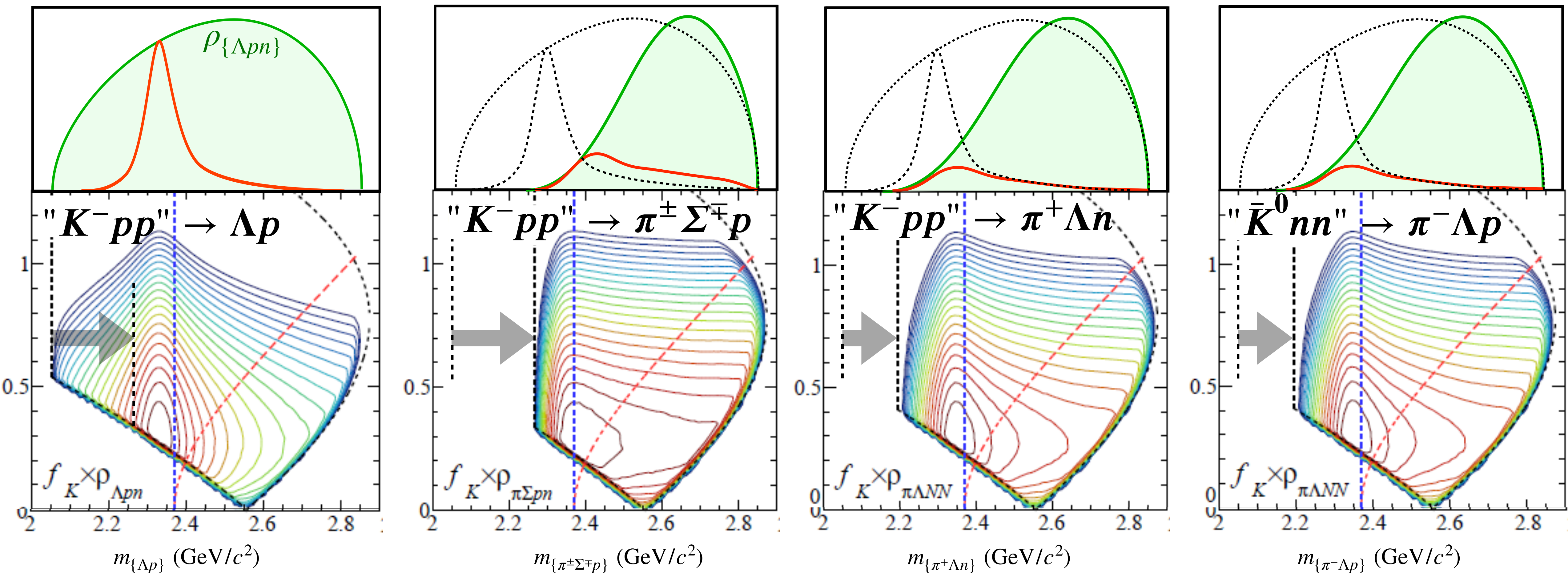

Mass spectra are expected to be modified substantially, due to *Phase Space*!

- 1) mass threshold $m_{\{\pi\Lambda p\}} \in [m_{\Lambda} + m_p, E_{\{K^3\text{He}\}}^* - m_n] \rightarrow [m_{\pi} + m_Y + m_N, E_{\{K^3\text{He}\}}^* - m_N]$
- 2) Near the thresholds, the four-body phase space is significantly suppressed compared to that of the three-body phase space.

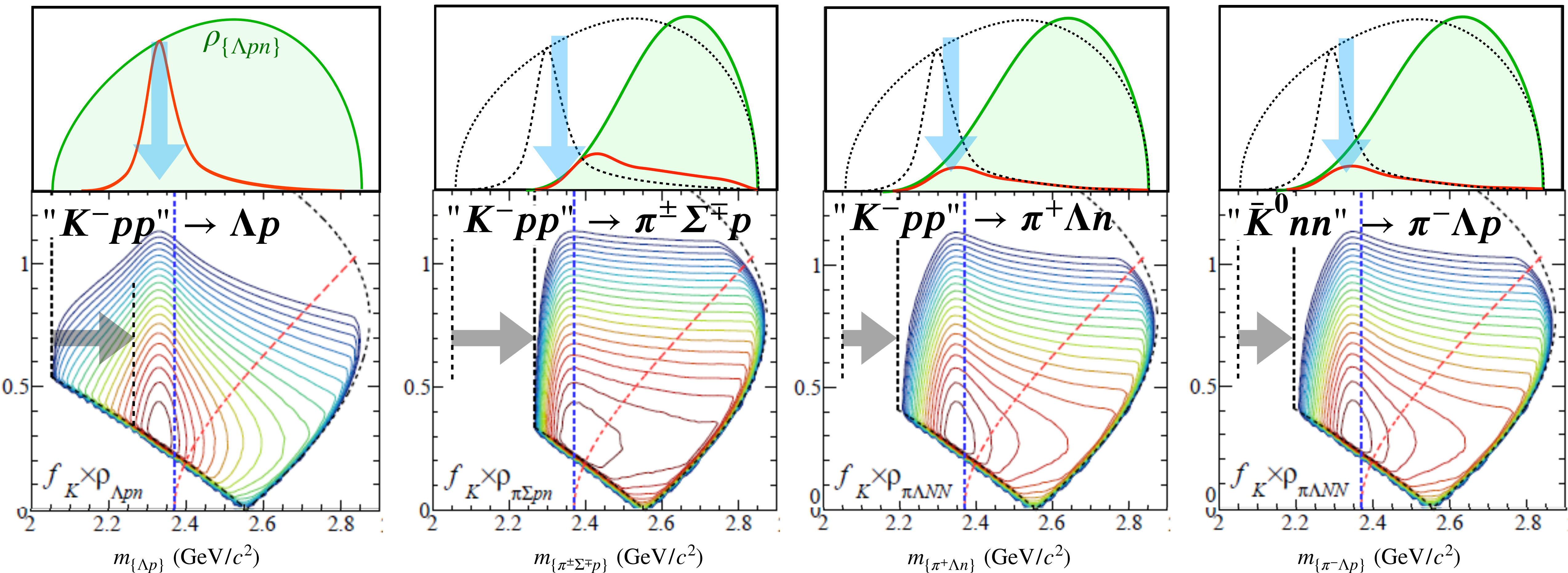

Mass spectra are expected to be modified substantially, due to *Phase Space*!

1) mass threshold $m_{\{\pi\Lambda p\}} \in [m_{\Lambda} + m_p, E_{\{K^3\text{He}\}}^* - m_n] \rightarrow [m_{\pi} + m_Y + m_N, E_{\{K^3\text{He}\}}^* - m_N]$

2) Near the thresholds, the four-body phase space is significantly suppressed compared to that of the three-body phase space.

Thus, we focus on the test whether the mass spectra are consistent with the $K^- + {}^3\text{He} \rightarrow \{\Lambda p\} + n'$ reaction dynamics.

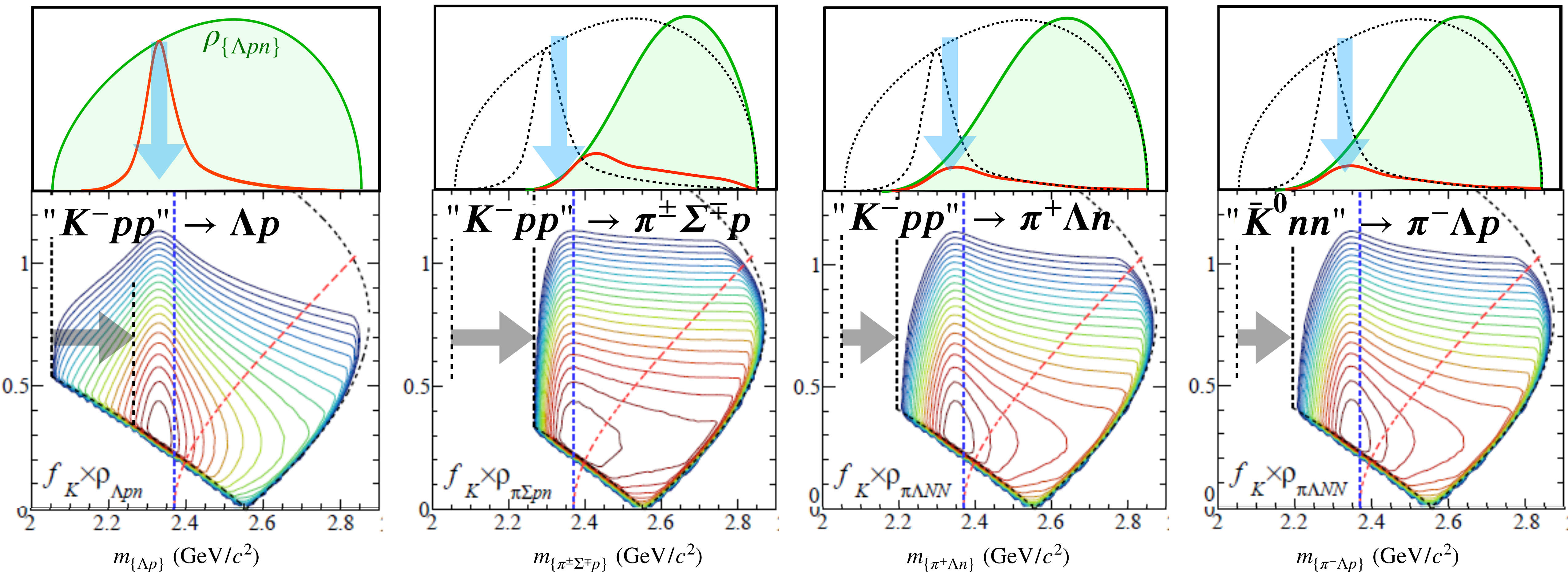

Mesonic Decay Analysis (with the E15 Data)

- with neutron detection using a thin scintillation counter array (CDH)
 - small efficiency (3~9%)
 - BG from the inner wall of the magnet

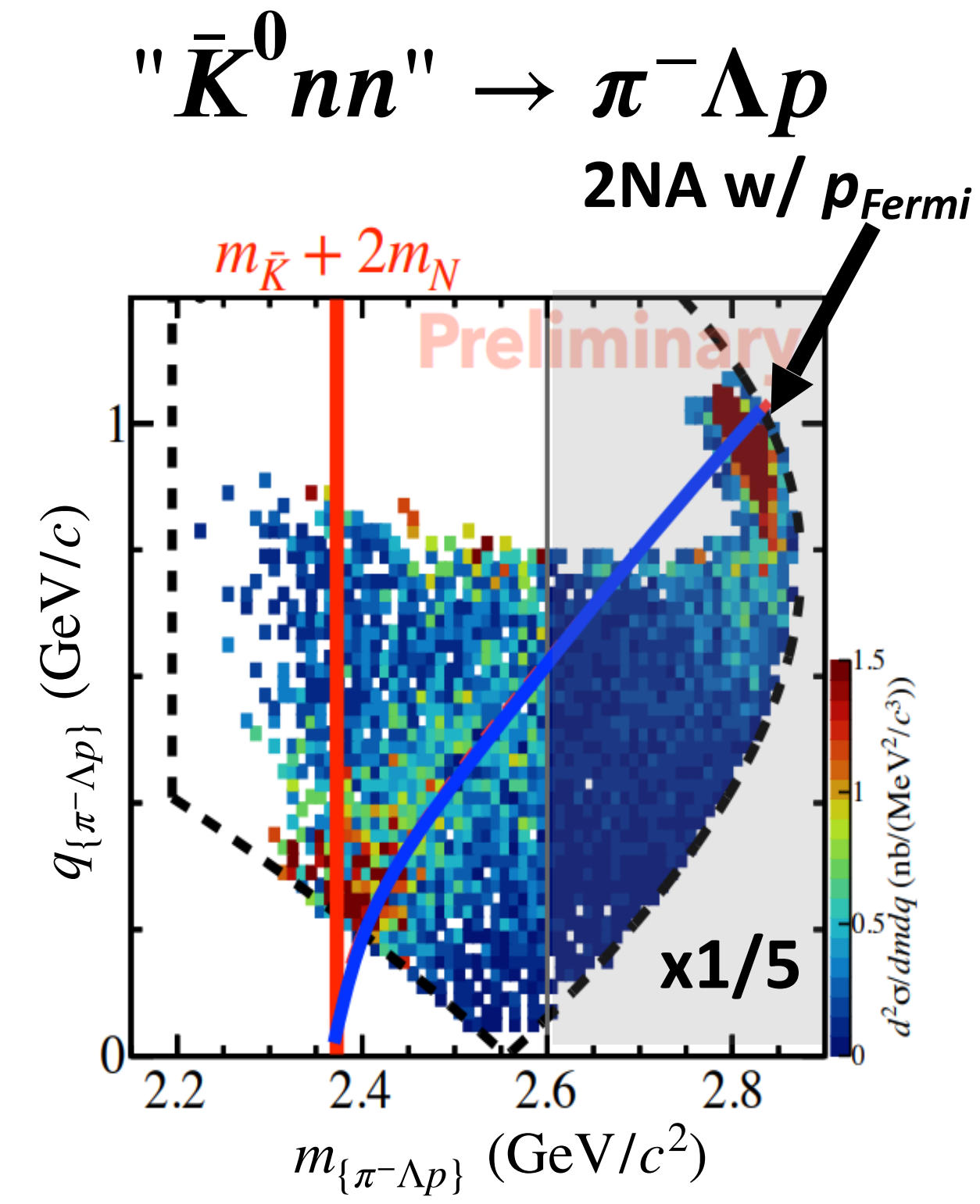
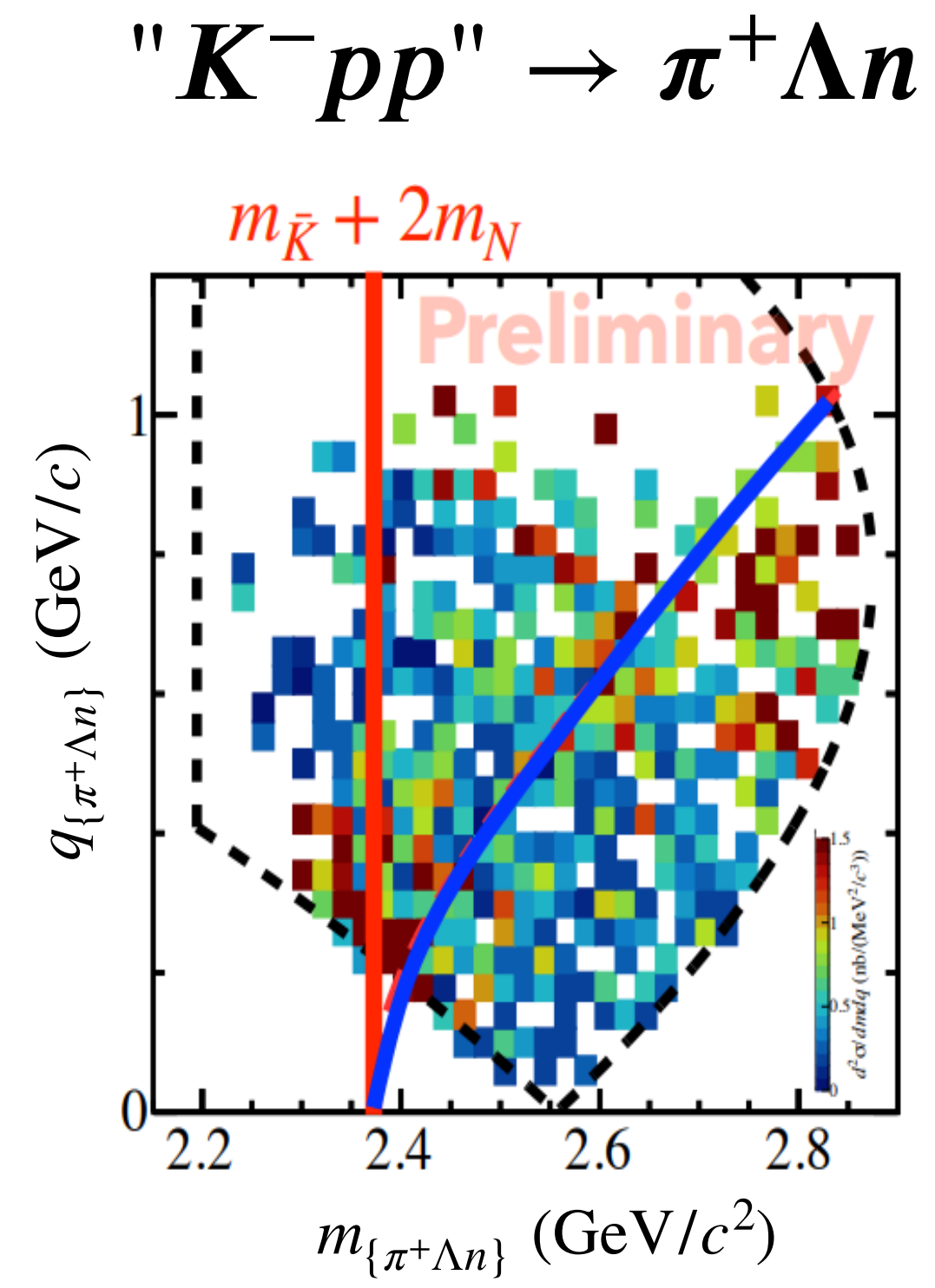
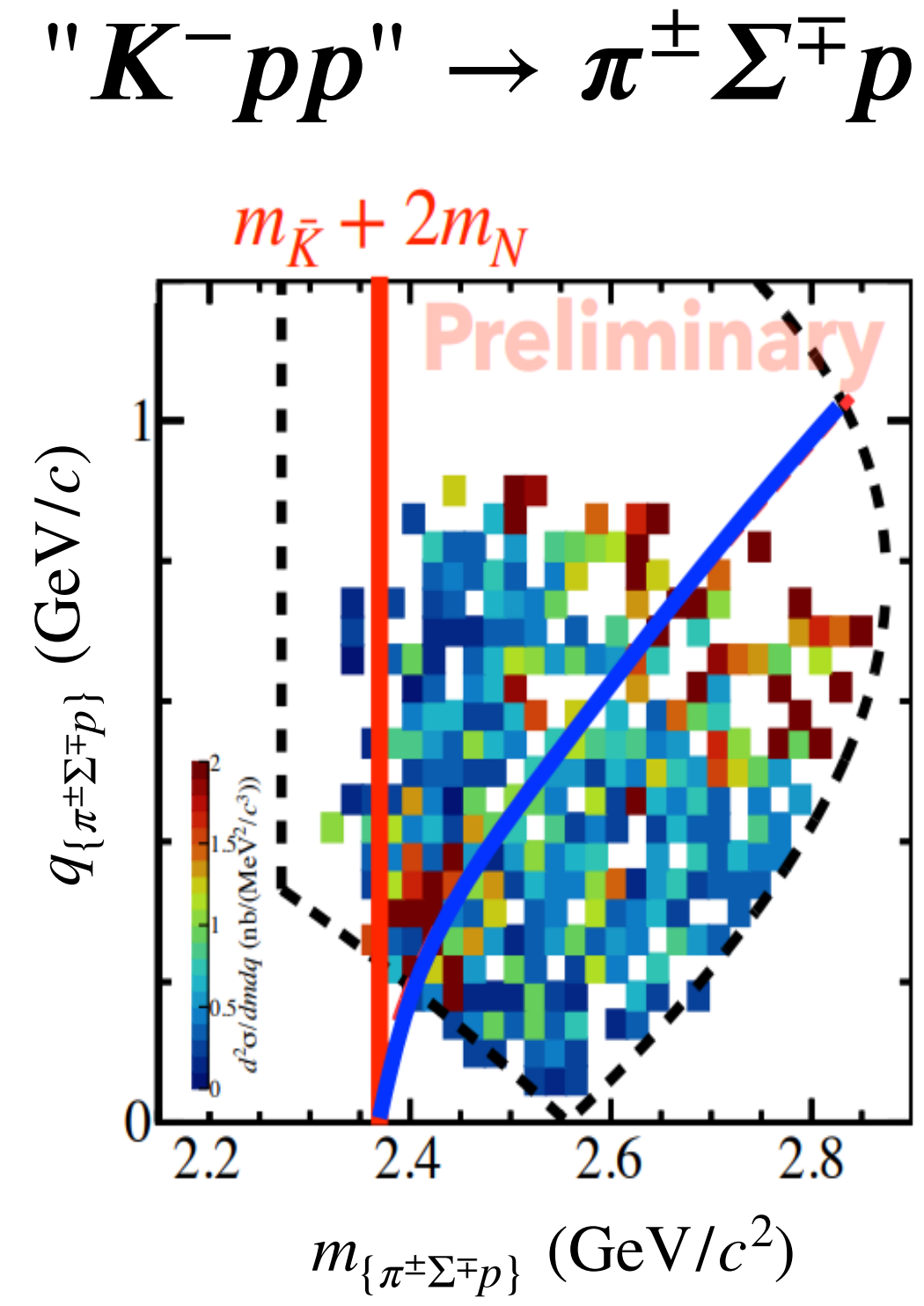
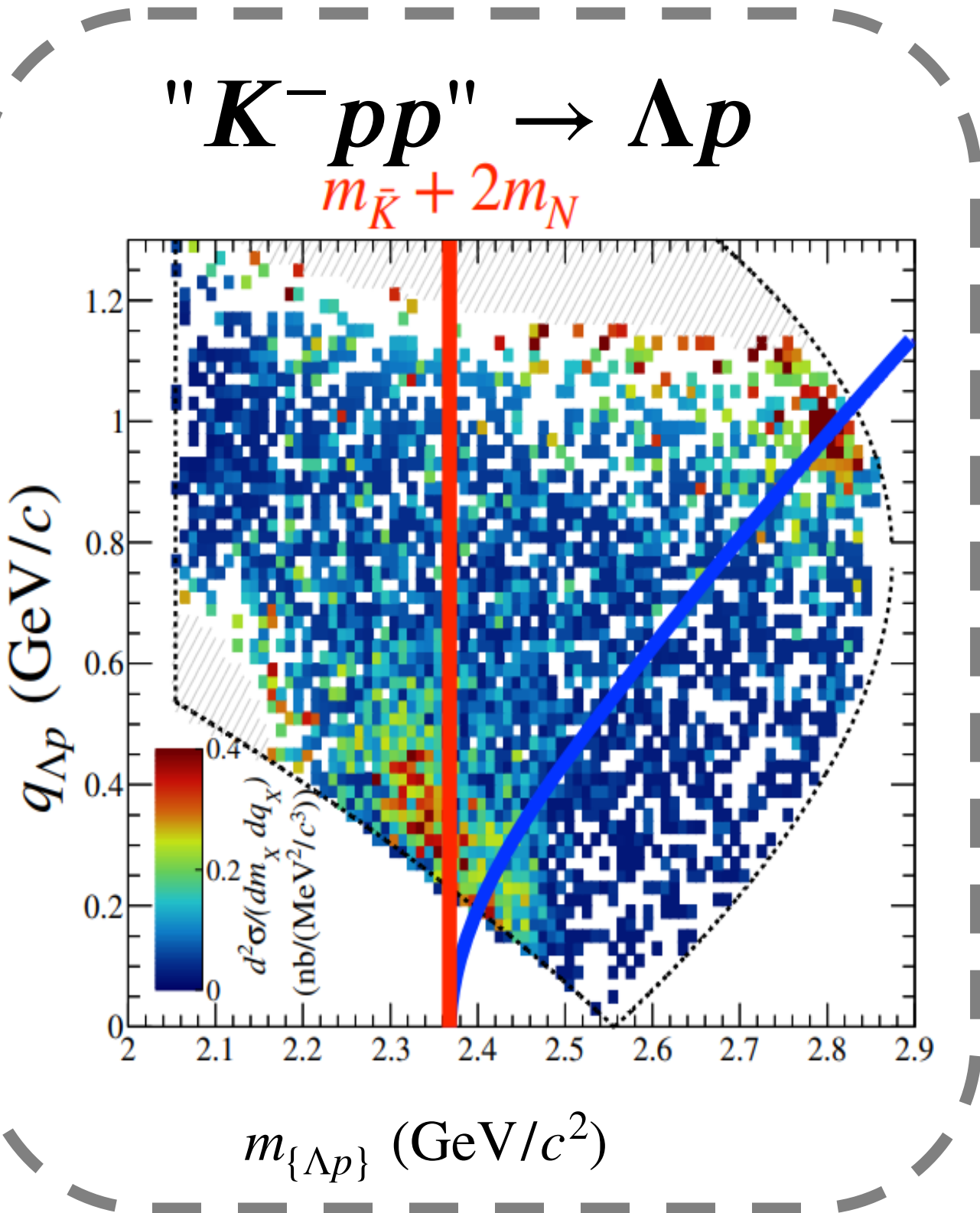
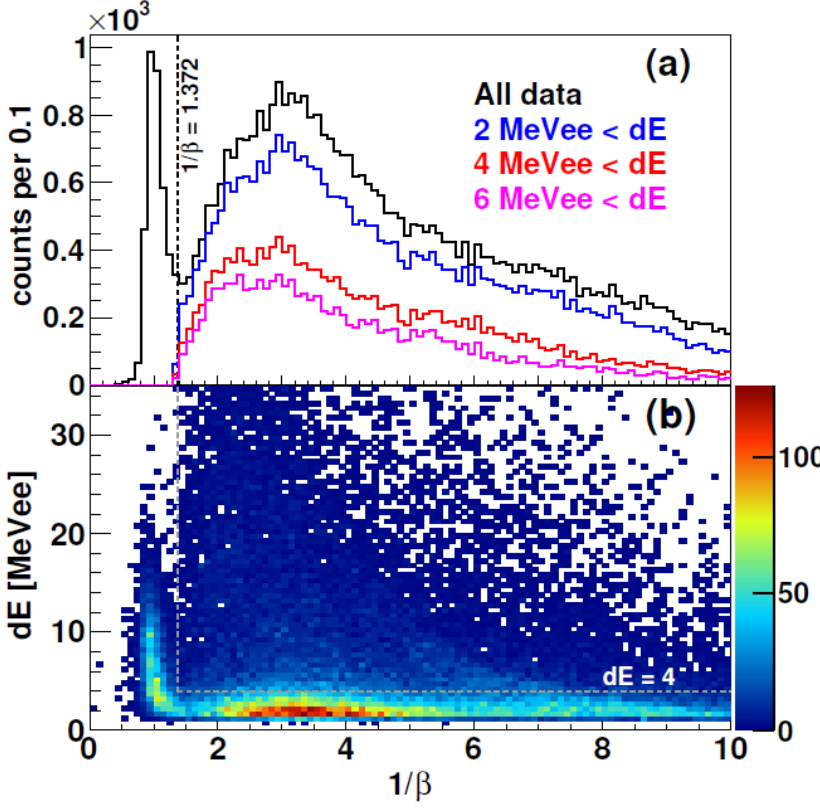
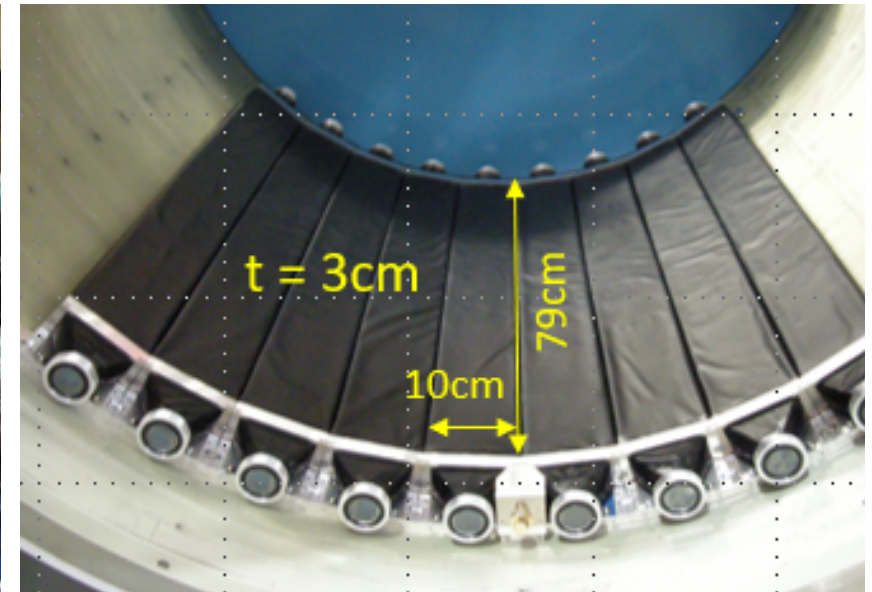
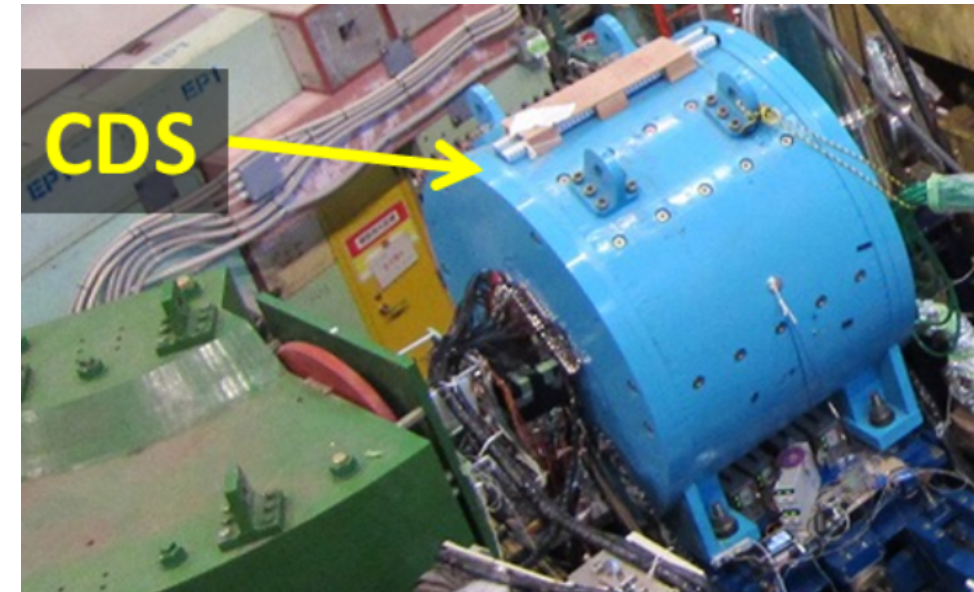

Mesonic Decay Analysis (with the E15 Data)

Plane Wave Impulse Approximation
Fit with PWIA $\sigma(M, q) \propto \rho(M, q) \times \frac{(\Gamma_{Kpp}/2)^2}{(M - M_{Kpp})^2 + (\Gamma_{Kpp}/2)^2} \times \exp\left(-\frac{q^2}{Q_{Kpp}^2}\right)$

Phase space
 Energy term (BW type) from time integral
 Momentum term from spatial integral

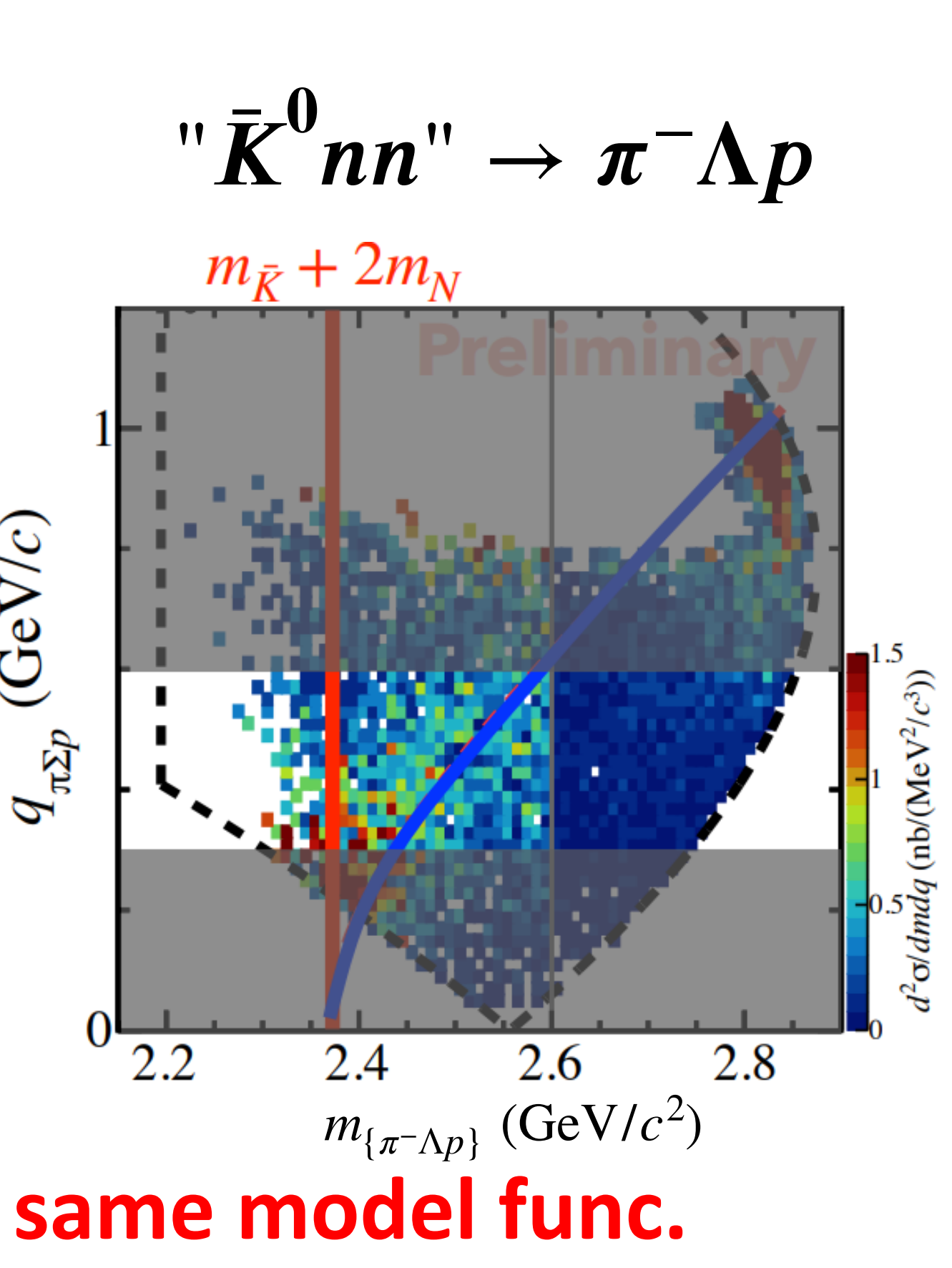
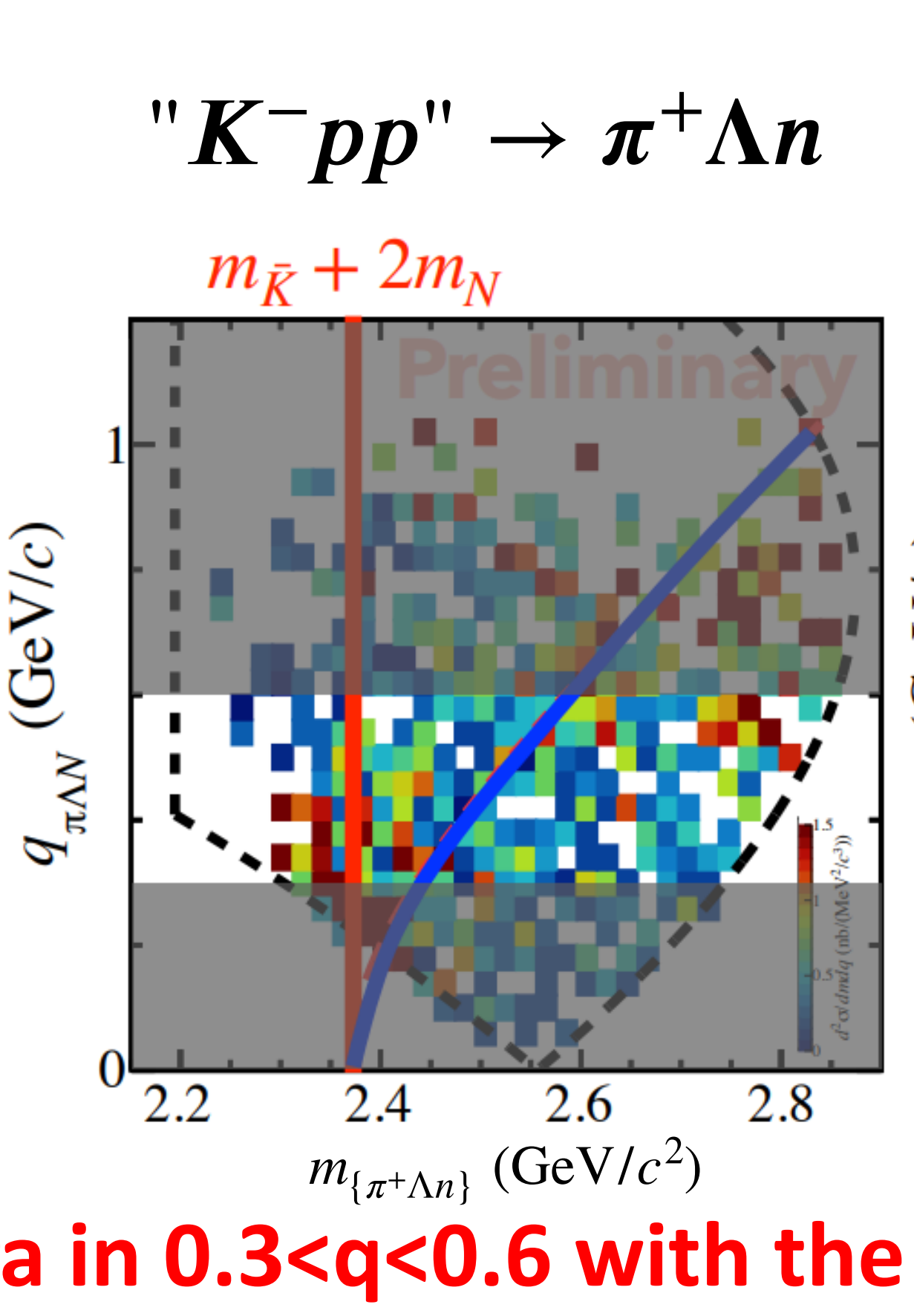
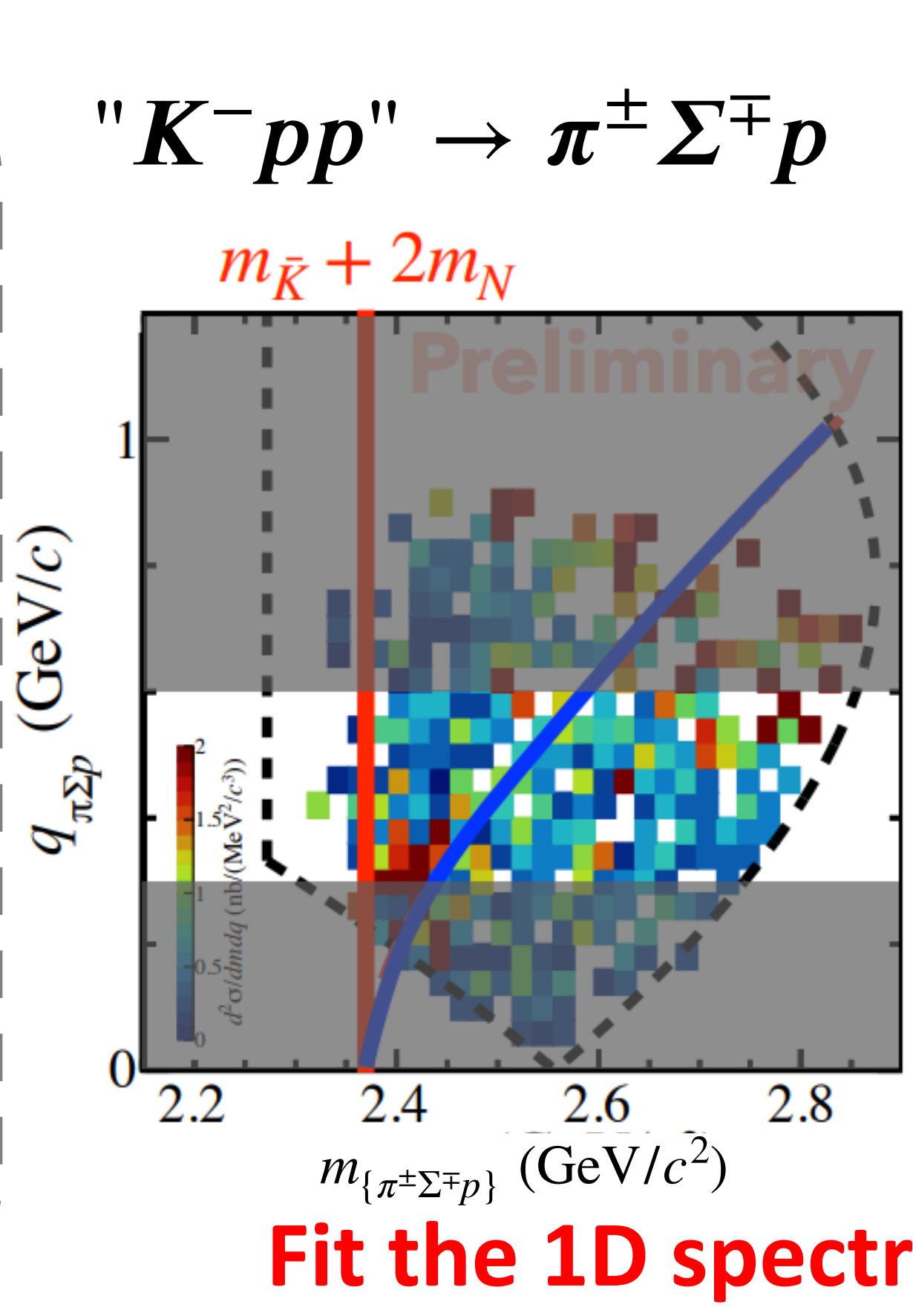
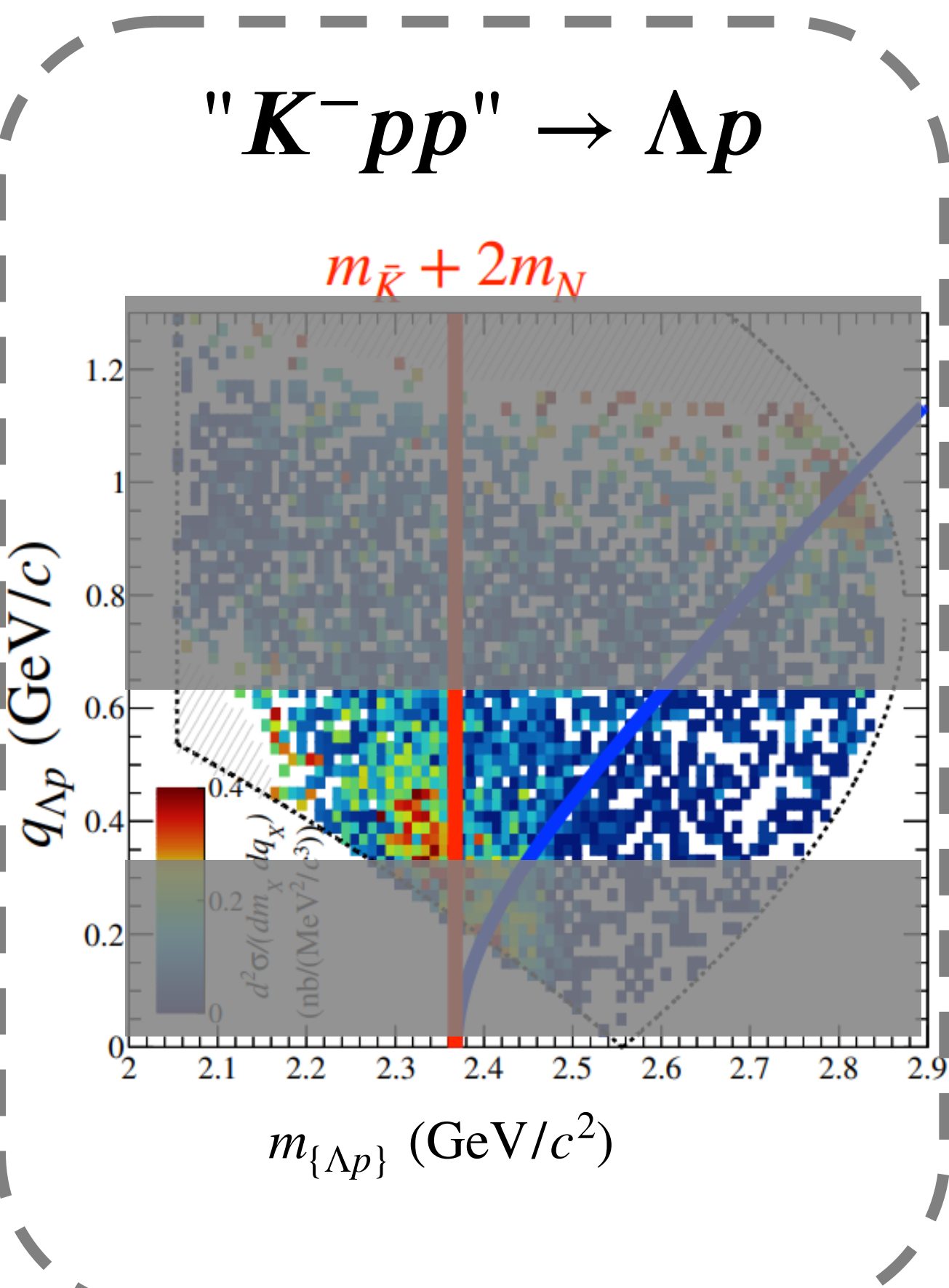

Fit the 1D spectra in $0.3 < q < 0.6$ with the same model func.

Mesonic Decay Analysis (with the E15 Data)

Plane Wave Impulse Approximation
Fit with PWIA $\sigma(M, q) \propto \rho(M, q) \times \frac{(\Gamma_{Kpp}/2)^2}{(M - M_{Kpp})^2 + (\Gamma_{Kpp}/2)^2} \times \exp\left(-\frac{q^2}{Q_{Kpp}^2}\right)$

Phase space (green box) Energy term (BW type) from time integral (red box) Momentum term from spatial integral (blue box)

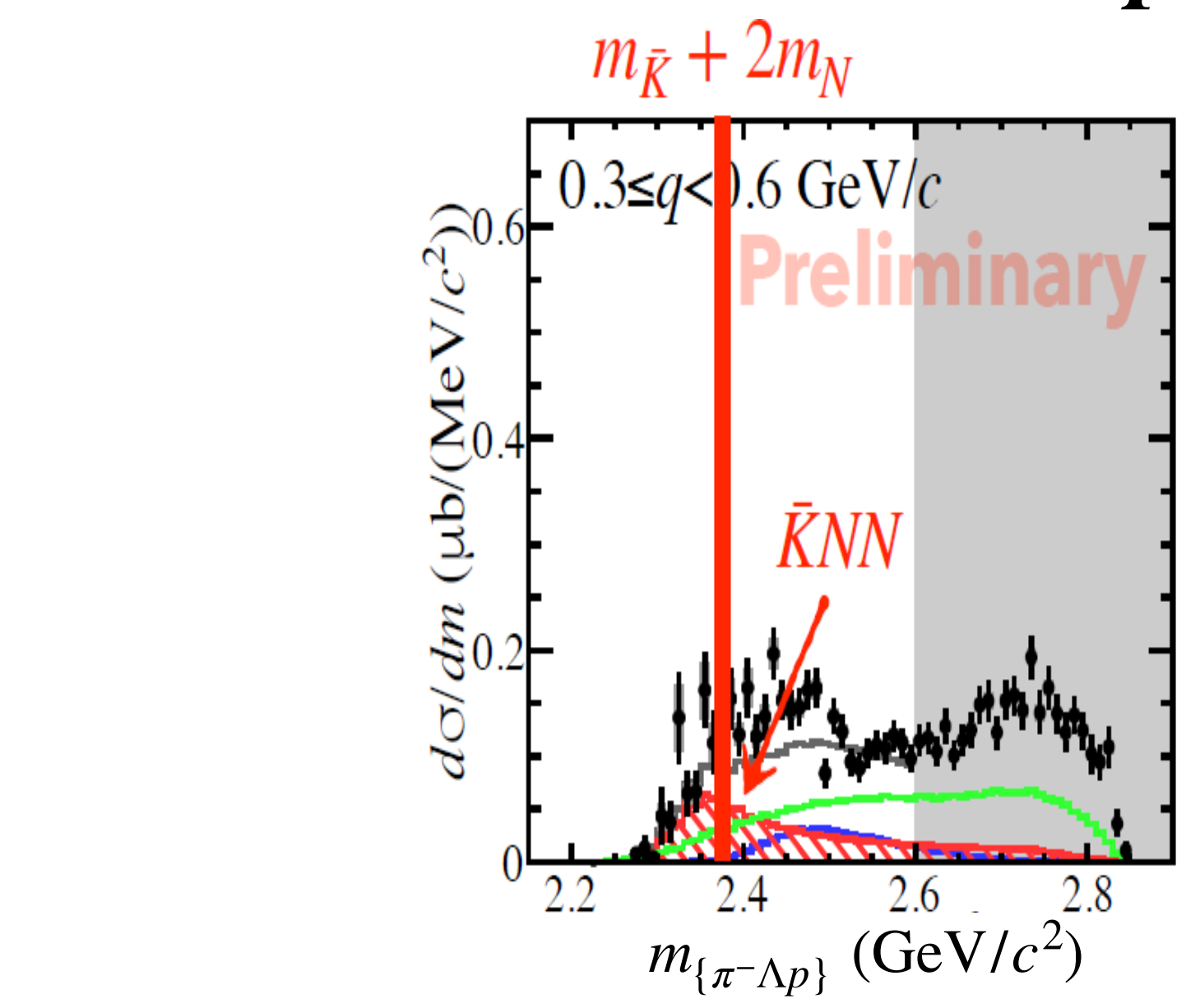
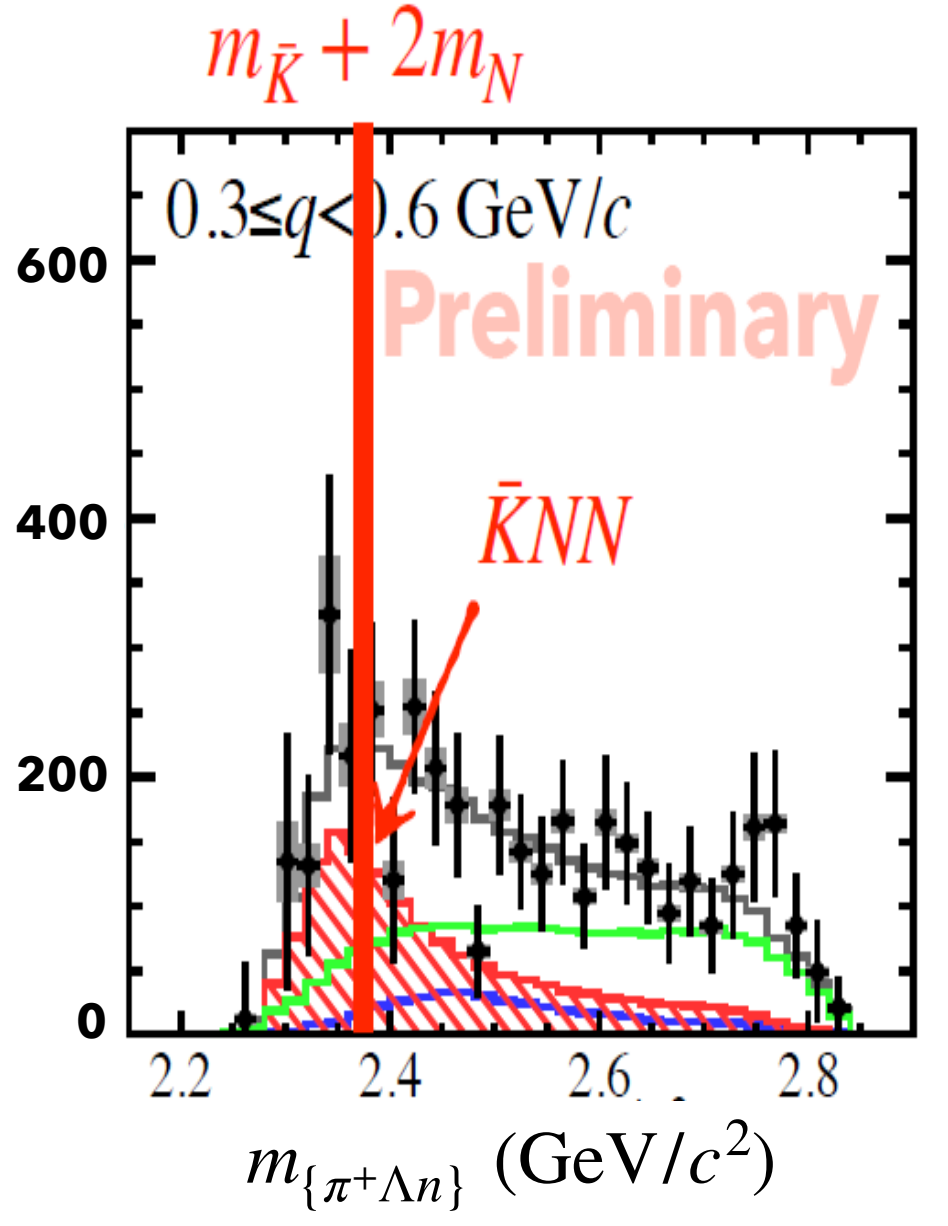
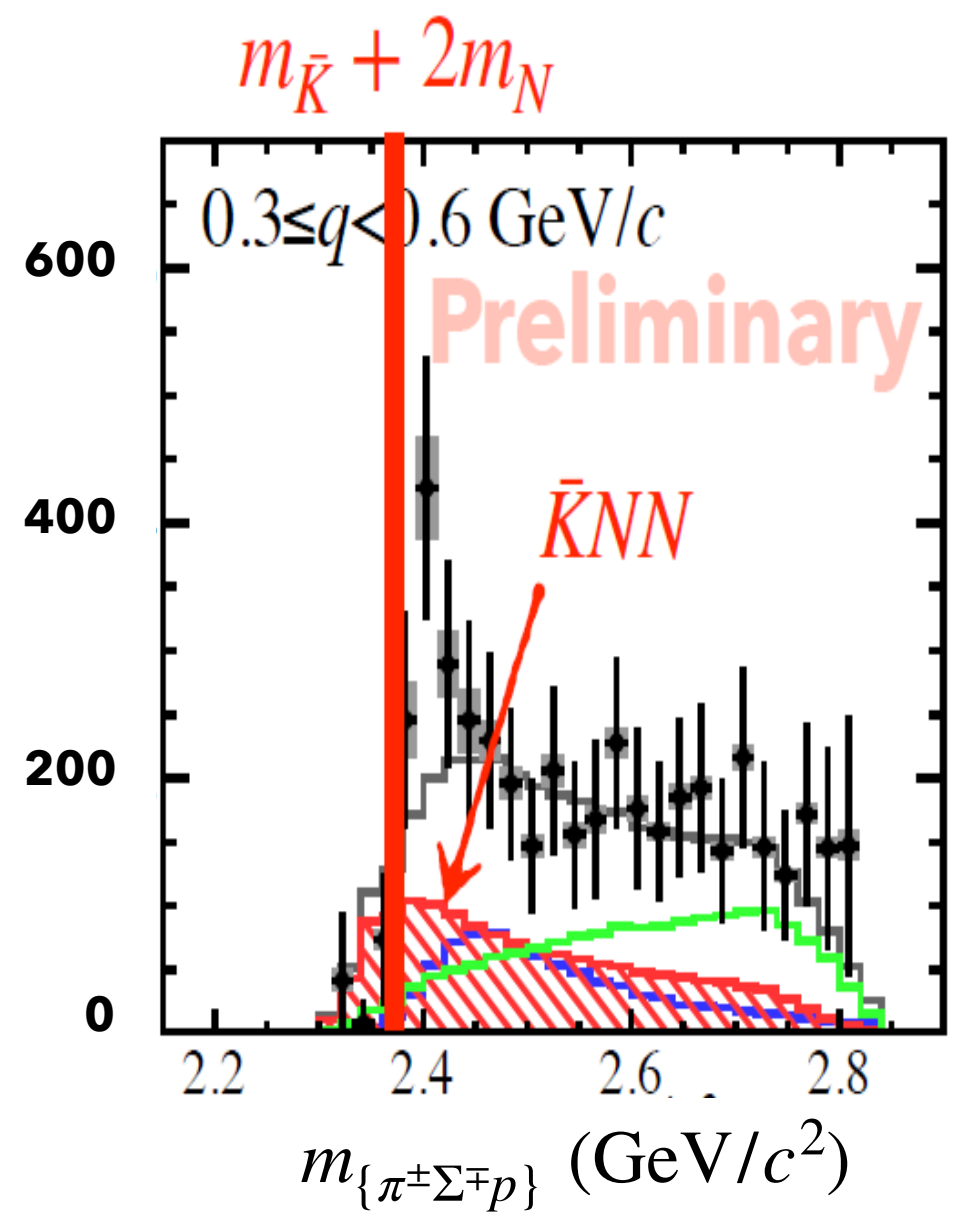
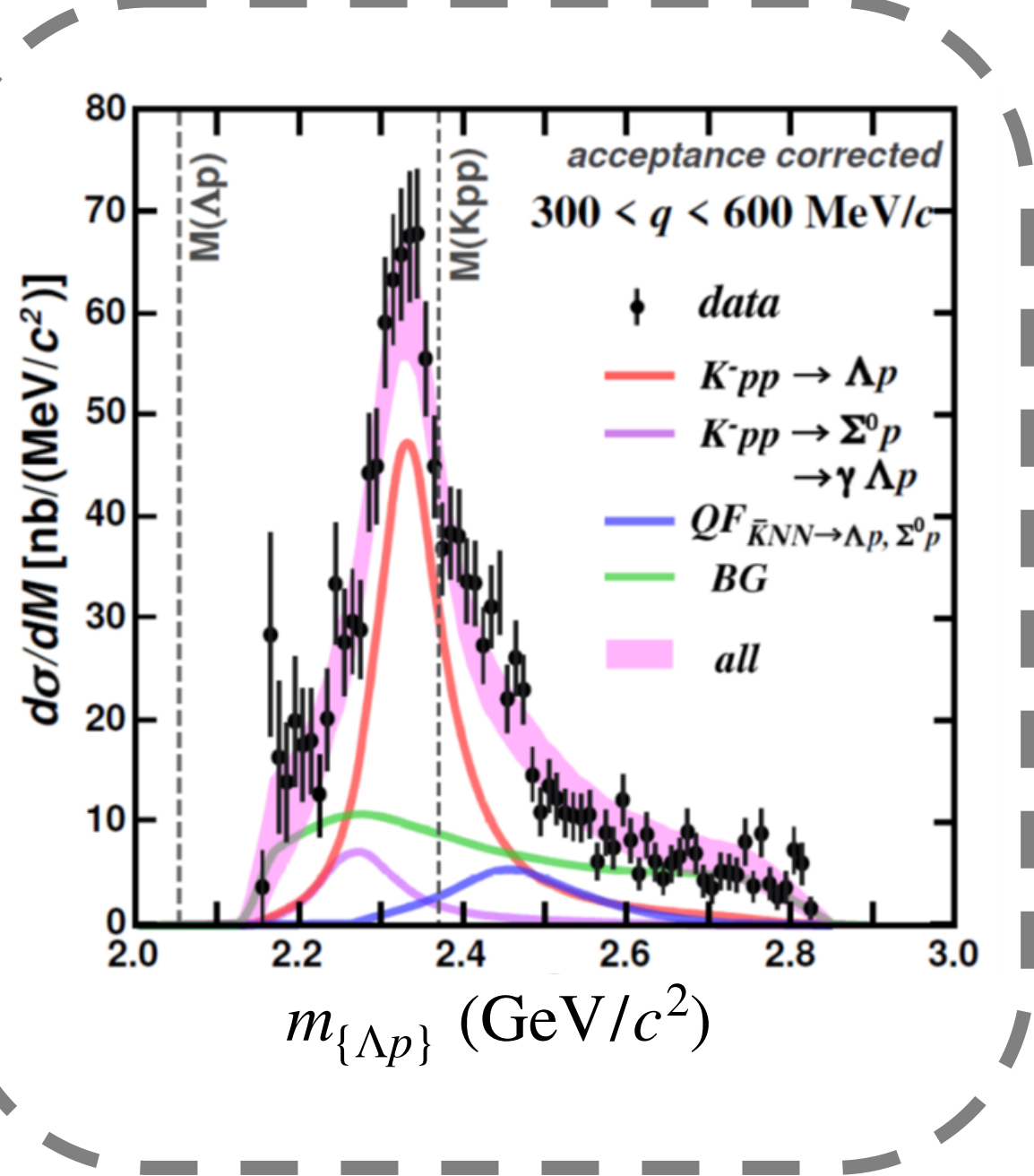
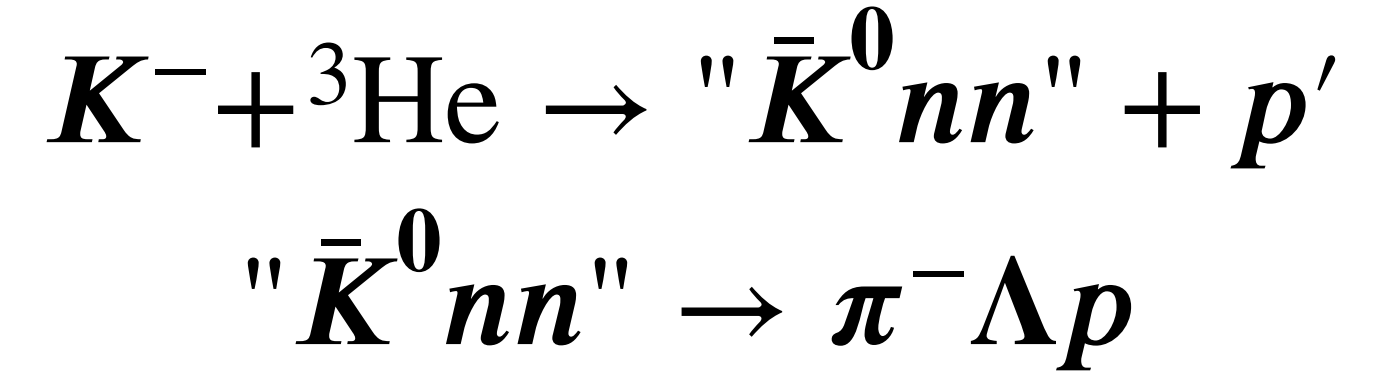
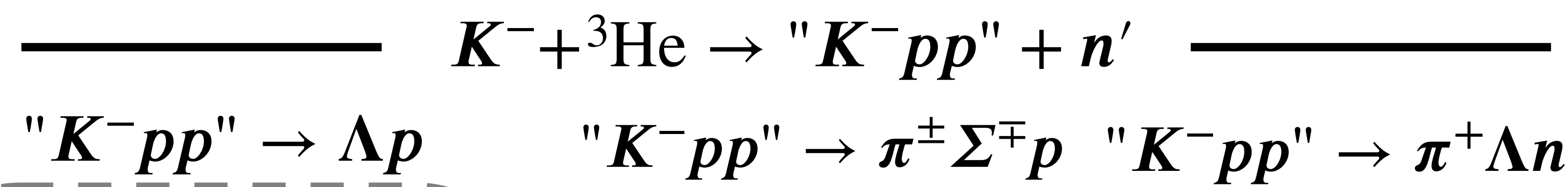

With the model func., the spectra are consistently explained.

Mesonic Decay Analysis (with the E15 Data)

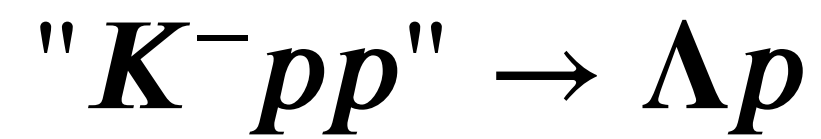

$$\sigma_{\bar{K}NN}^{tot} \times Br (\mu b) =$$

$$9.3 \pm 0.8^{+1.4}_{-1.0} \text{ [all]}$$

$$5.5 \pm 0.5^{+0.8}_{-0.6} \text{ [<M(KNN)]}$$

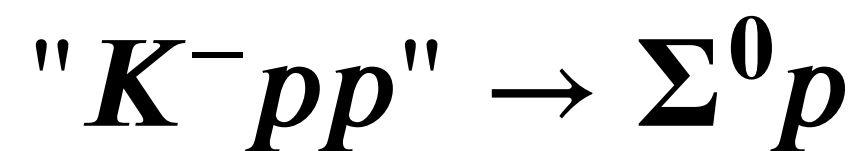

$$\sigma_{\bar{K}NN}^{tot} \times Br (\mu b) =$$

$$5.3 \pm 0.4^{+0.8}_{-0.6} \text{ [all]}$$

$$3.1 \pm 0.2^{+0.5}_{-0.4} \text{ [<M(KNN)]}$$

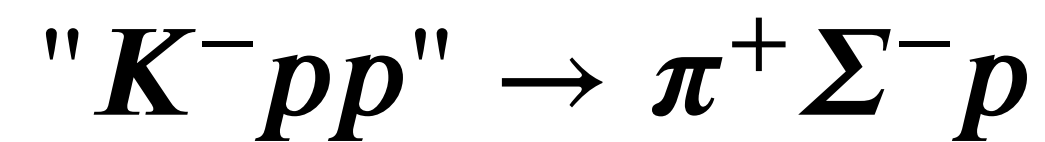

$$\sigma_{\bar{K}NN}^{tot} \times Br (\mu b) =$$

$$38 \pm 3 \pm 3 \text{ [all]}$$

$$3.2 \pm 0.2 \pm 0.2 \text{ [<M(KNN)]}$$

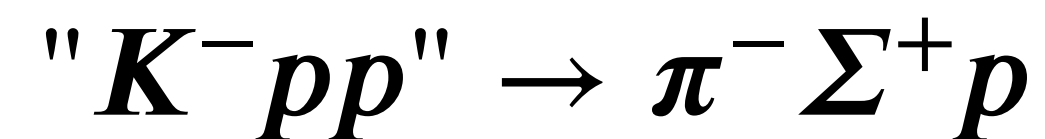

$$\sigma_{\bar{K}NN}^{tot} \times Br (\mu b) =$$

$$110 \pm 8 \pm 8 \text{ [all]}$$

$$9.4 \pm 0.4 \pm 0.7 \text{ [<M(KNN)]}$$

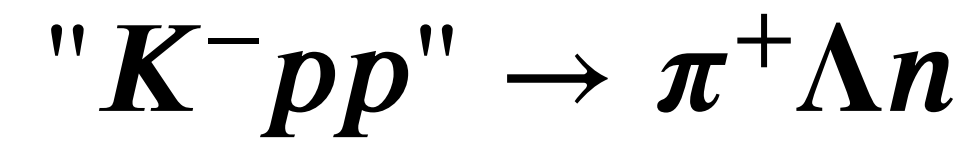

$$\sigma_{\bar{K}NN}^{tot} \times Br (\mu b) =$$

$$62 \pm 11 \pm 9 \text{ [all]}$$

$$15.5 \pm 2.7 \pm 2.1 \text{ [<M(KNN)]}$$

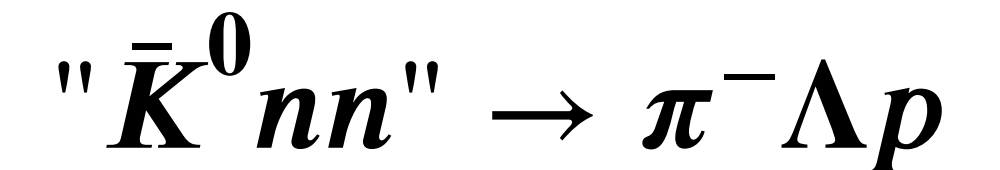

$$\sigma_{\bar{K}NN}^{tot} \times Br (\mu b) =$$

$$29 \pm 3 \pm 3 \text{ [all]}$$

$$7.2 \pm 0.6 \pm 0.7 \text{ [<M(KNN)]}$$

Mesonic Decay Analysis (with the E15 Data)

- $\Gamma_{YN} < \Gamma_{\pi YN}$: mesonic decay is dominant (about ~ 10 times in total)

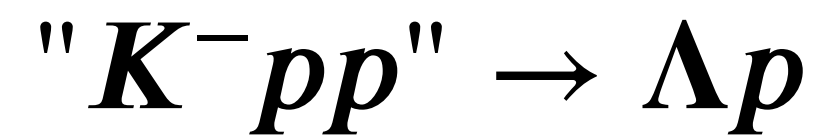

$$\sigma_{\bar{K}NN}^{tot} \times Br (\mu b) =$$

$$9.3 \pm 0.8^{+1.4}_{-1.0} \text{ [all]}$$

$$5.5 \pm 0.5^{+0.8}_{-0.6} \text{ [<M(KNN)]}$$

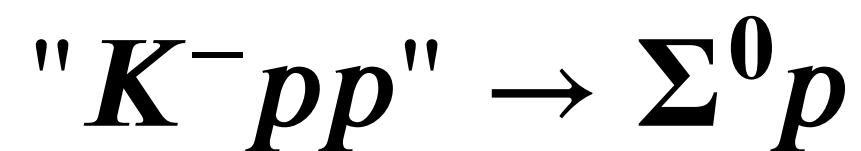

$$\sigma_{\bar{K}NN}^{tot} \times Br (\mu b) =$$

$$5.3 \pm 0.4^{+0.8}_{-0.6} \text{ [all]}$$

$$3.1 \pm 0.2^{+0.5}_{-0.4} \text{ [<M(KNN)]}$$

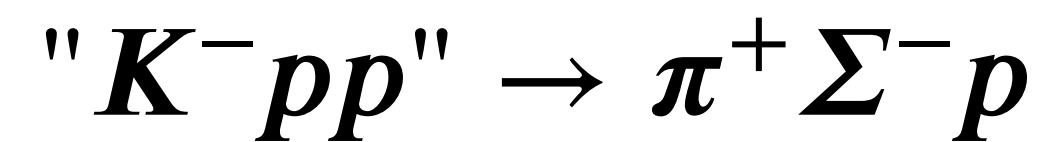

$$\sigma_{\bar{K}NN}^{tot} \times Br (\mu b) =$$

$$38 \pm 3 \pm 3 \text{ [all]}$$

$$3.2 \pm 0.2 \pm 0.2 \text{ [<M(KNN)]}$$

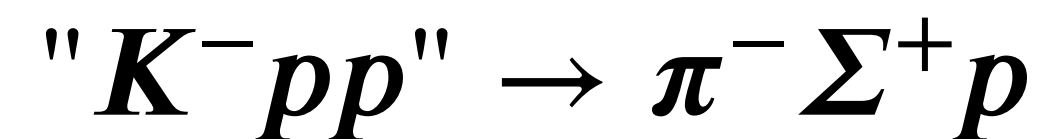

$$\sigma_{\bar{K}NN}^{tot} \times Br (\mu b) =$$

$$110 \pm 8 \pm 8 \text{ [all]}$$

$$9.4 \pm 0.4 \pm 0.7 \text{ [<M(KNN)]}$$

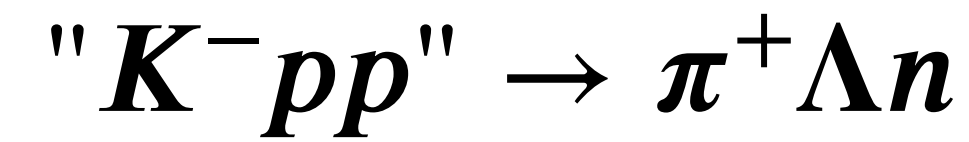

$$\sigma_{\bar{K}NN}^{tot} \times Br (\mu b) =$$

$$62 \pm 11 \pm 9 \text{ [all]}$$

$$15.5 \pm 2.7 \pm 2.1 \text{ [<M(KNN)]}$$

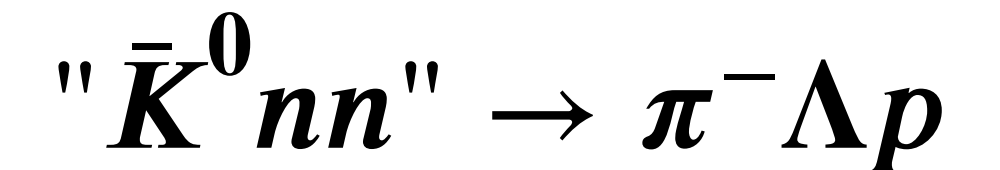

$$\sigma_{\bar{K}NN}^{tot} \times Br (\mu b) =$$

$$29 \pm 3 \pm 3 \text{ [all]}$$

$$7.2 \pm 0.6 \pm 0.7 \text{ [<M(KNN)]}$$

Mesonic Decay Analysis (with the E15 Data)

- $\Gamma_{\Upsilon N} < \Gamma_{\pi\Upsilon N}$: mesonic decay is dominant (about ~ 10 times in total)
- $\Gamma_{\pi\Sigma N} \sim \Gamma_{\pi\Lambda N}$: significant contribution of the $I_{KN} = 1$ as well as $I_{KN} = 0$



$$\sigma_{\bar{K}NN}^{tot} \times Br (\mu b) =$$

$$9.3 \pm 0.8^{+1.4}_{-1.0} \text{ [all]}$$

$$5.5 \pm 0.5^{+0.8}_{-0.6} \text{ [<M(KNN)]}$$

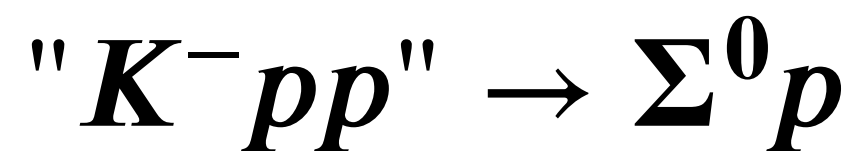

$$\sigma_{\bar{K}NN}^{tot} \times Br (\mu b) =$$

$$5.3 \pm 0.4^{+0.8}_{-0.6} \text{ [all]}$$

$$3.1 \pm 0.2^{+0.5}_{-0.4} \text{ [<M(KNN)]}$$

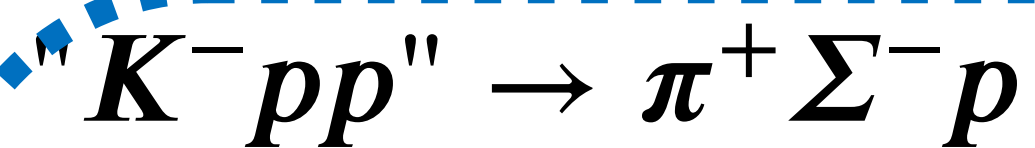

$$\sigma_{\bar{K}NN}^{tot} \times Br (\mu b) =$$

$$38 \pm 3 \pm 3 \text{ [all]}$$

$$3.2 \pm 0.2 \pm 0.2 \text{ [<M(KNN)]}$$

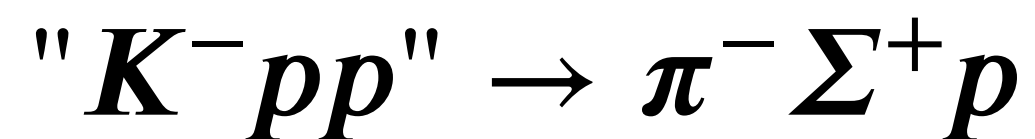

$$\sigma_{\bar{K}NN}^{tot} \times Br (\mu b) =$$

$$110 \pm 8 \pm 8 \text{ [all]}$$

$$9.4 \pm 0.4 \pm 0.7 \text{ [<M(KNN)]}$$



$$\sigma_{\bar{K}NN}^{tot} \times Br (\mu b) =$$

$$62 \pm 11 \pm 9 \text{ [all]}$$

$$15.5 \pm 2.7 \pm 2.1 \text{ [<M(KNN)]}$$

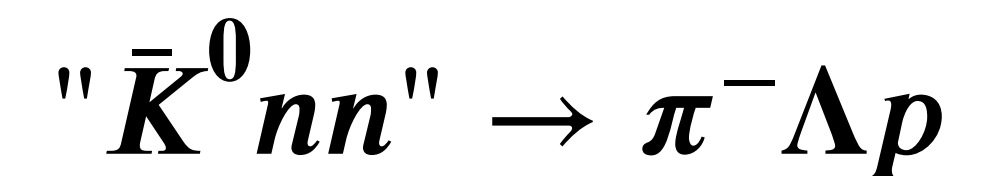

$$\sigma_{\bar{K}NN}^{tot} \times Br (\mu b) =$$

$$29 \pm 3 \pm 3 \text{ [all]}$$

$$7.2 \pm 0.6 \pm 0.7 \text{ [<M(KNN)]}$$

Mesonic Decay Analysis (with the E15 Data)

- $\Gamma_{\Upsilon N} < \Gamma_{\pi\Upsilon N}$: mesonic decay is dominant (about ~ 10 times in total)
- $\Gamma_{\pi\Sigma N} \sim \Gamma_{\pi\Lambda N}$: significant contribution of the $I_{KN} = 1$ as well as $I_{KN} = 0$
- $\Gamma_{\pi+\Lambda n} / \Gamma_{\pi-\Lambda p} \sim 2$: if we assume $\text{Br}_{K^-pp \rightarrow \pi+\Lambda n} = \text{Br}_{K^0nn \rightarrow \pi-\Lambda p} \rightarrow \sigma_{K^-pp} / \sigma_{K^0nn} \sim 2$



$$\sigma_{\bar{K}NN}^{tot} \times Br (\mu b) =$$

$$9.3 \pm 0.8_{-1.0}^{+1.4} \text{ [all]}$$

$$5.5 \pm 0.5_{-0.6}^{+0.8} \text{ [<M(KNN)]}$$

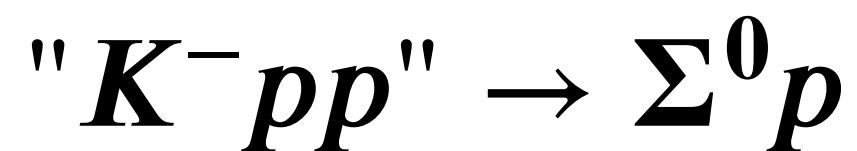

$$\sigma_{\bar{K}NN}^{tot} \times Br (\mu b) =$$

$$5.3 \pm 0.4_{-0.6}^{+0.8} \text{ [all]}$$

$$3.1 \pm 0.2_{-0.4}^{+0.5} \text{ [<M(KNN)]}$$

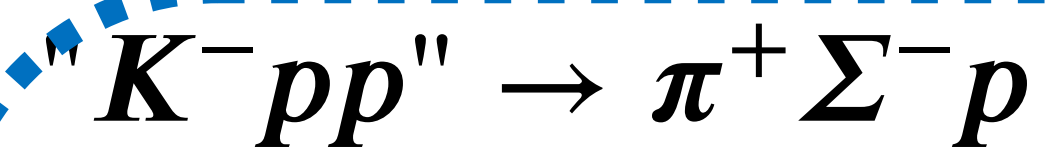

$$\sigma_{\bar{K}NN}^{tot} \times Br (\mu b) =$$

$$38 \pm 3 \pm 3 \text{ [all]}$$

$$3.2 \pm 0.2 \pm 0.2 \text{ [<M(KNN)]}$$

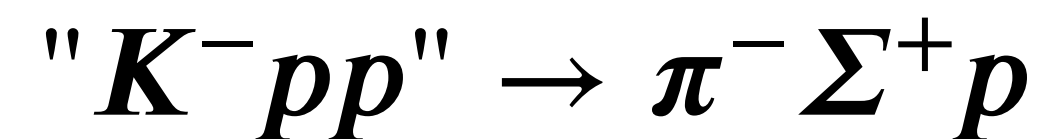

$$\sigma_{\bar{K}NN}^{tot} \times Br (\mu b) =$$

$$110 \pm 8 \pm 8 \text{ [all]}$$

$$9.4 \pm 0.4 \pm 0.7 \text{ [<M(KNN)]}$$



$$\sigma_{\bar{K}NN}^{tot} \times Br (\mu b) =$$

$$62 \pm 11 \pm 9 \text{ [all]}$$

$$15.5 \pm 2.7 \pm 2.1 \text{ [<M(KNN)]}$$

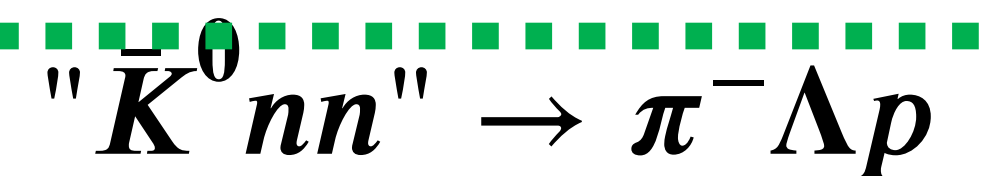

$$\sigma_{\bar{K}NN}^{tot} \times Br (\mu b) =$$

$$29 \pm 3 \pm 3 \text{ [all]}$$

$$7.2 \pm 0.6 \pm 0.7 \text{ [<M(KNN)]}$$

Mesonic Decay Analysis (with the E15 Data)

- $\Gamma_{YN} < \Gamma_{\pi YN}$: mesonic decay is dominant (about ~ 10 times in total)
- $\Gamma_{\pi\Sigma N} \sim \Gamma_{\pi\Lambda N}$: significant contribution of the $I_{KN} = 1$ as well as $I_{KN} = 0$
- $\Gamma_{\pi+\Lambda n} / \Gamma_{\pi-\Lambda p} \sim 2$: if we assume $Br_{K^{-}pp \rightarrow \pi^{+}\Lambda n} = Br_{K^{0}nn \rightarrow \pi^{-}\Lambda p} \rightarrow \sigma_{K^{-}pp} / \sigma_{K^{0}nn} \sim 2$



$$\sigma_{\bar{K}NN}^{tot} \times Br (\mu b) =$$

$$9.3 \pm 0.8^{+1.4}_{-1.0} \text{ [all]}$$

$$5.5 \pm 0.5^{+0.8}_{-0.6} \text{ [<M(KNN)]}$$

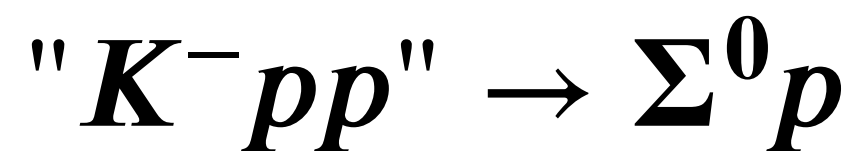

$$\sigma_{\bar{K}NN}^{tot} \times Br (\mu b) =$$

$$5.3 \pm 0.4^{+0.8}_{-0.6} \text{ [all]}$$

$$3.1 \pm 0.2^{+0.5}_{-0.4} \text{ [<M(KNN)]}$$

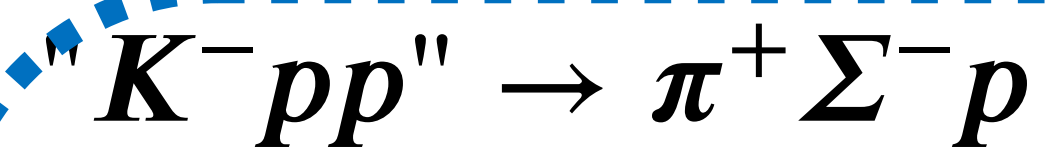

$$\sigma_{\bar{K}NN}^{tot} \times Br (\mu b) =$$

$$38 \pm 3 \pm 3 \text{ [all]}$$

$$3.2 \pm 0.2 \pm 0.2 \text{ [<M(KNN)]}$$

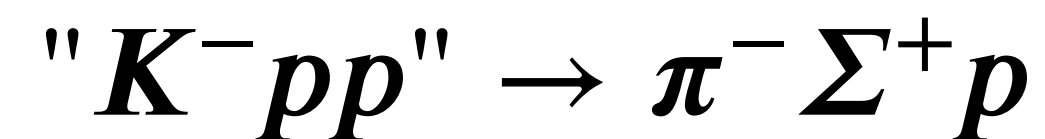

$$\sigma_{\bar{K}NN}^{tot} \times Br (\mu b) =$$

$$110 \pm 8 \pm 8 \text{ [all]}$$

$$9.4 \pm 0.4 \pm 0.7 \text{ [<M(KNN)]}$$



$$\sigma_{\bar{K}NN}^{tot} \times Br (\mu b) =$$

$$62 \pm 11 \pm 9 \text{ [all]}$$

$$15.5 \pm 2.7 \pm 2.1 \text{ [<M(KNN)]}$$

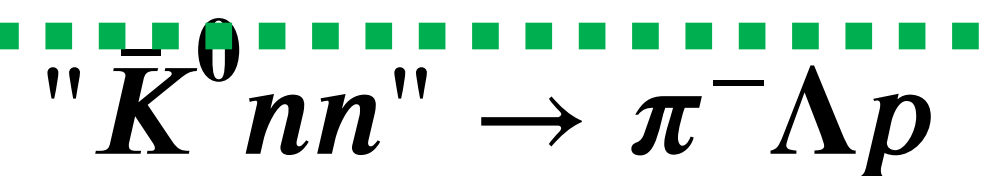

$$\sigma_{\bar{K}NN}^{tot} \times Br (\mu b) =$$

$$29 \pm 3 \pm 3 \text{ [all]}$$

$$7.2 \pm 0.6 \pm 0.7 \text{ [<M(KNN)]}$$

More precise measurements
and theoretical investigations
are needed

Mesonic decay branch of $\bar{K}^0 nn$?

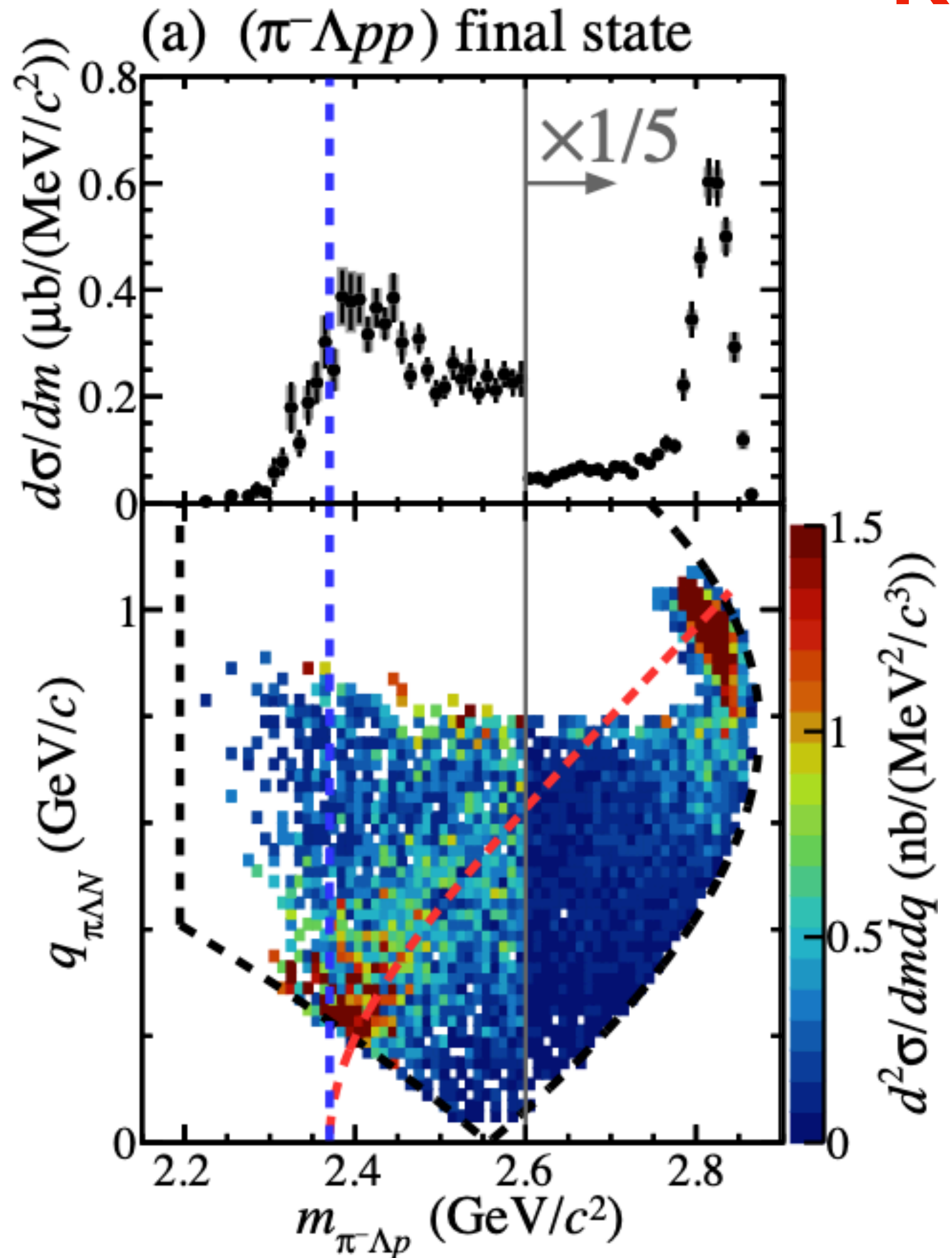
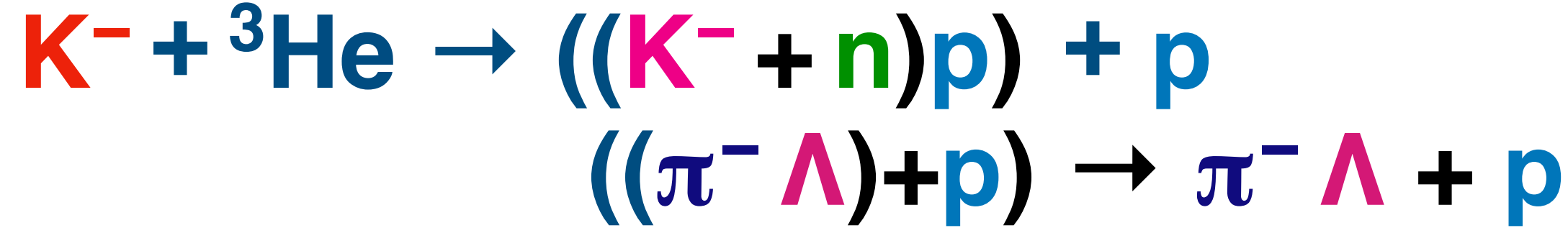

Mesonic decay branch of $\bar{K}^0 nn$?

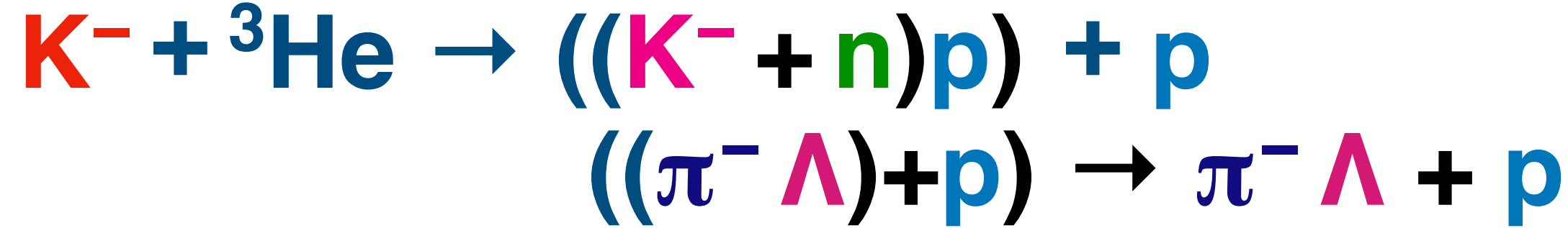

... but the *excess* is still not easy to see ...

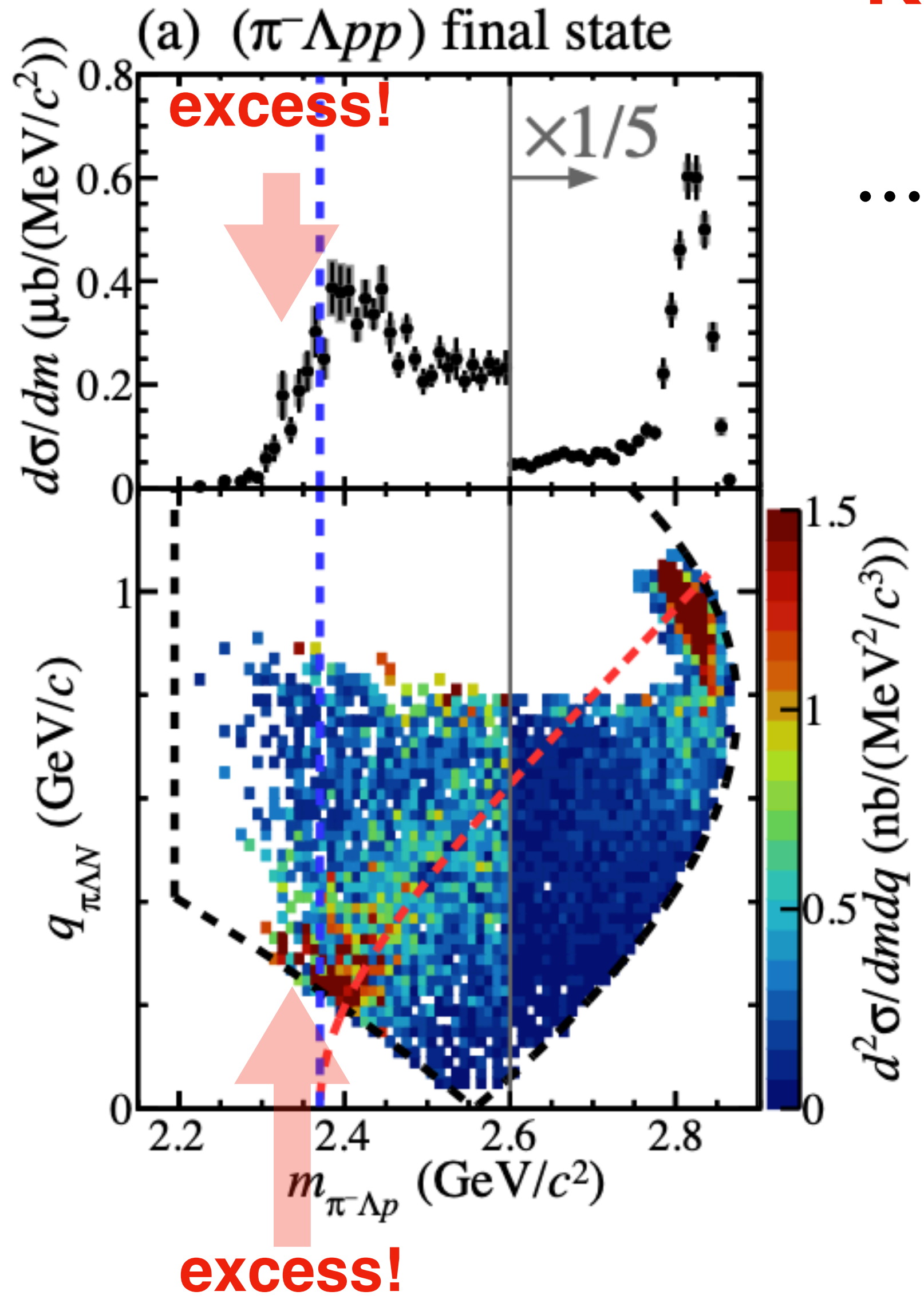

Mesonic decay branch of $\bar{K}^0 nn$?

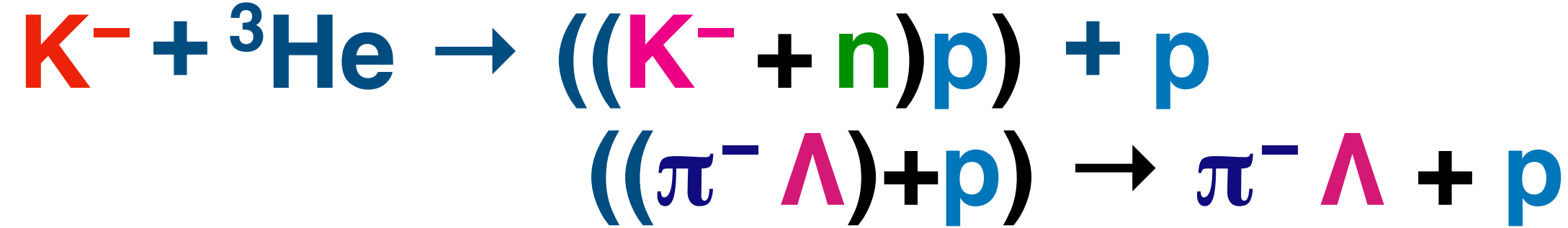

... but the *excess* is still not easy to see ... due to the *QF-K*

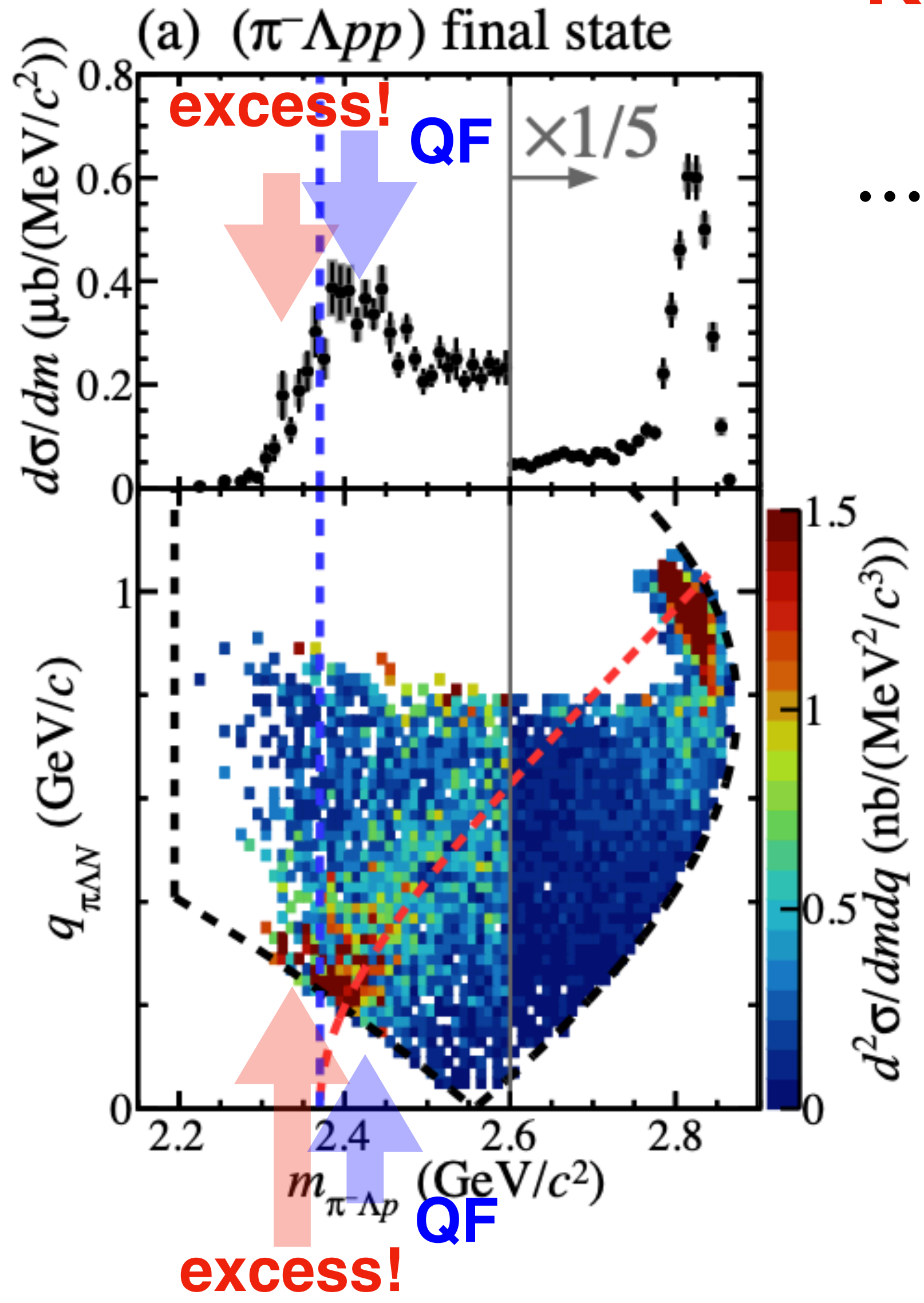

Mesonic decay branch of $\bar{K}^0 nn$?

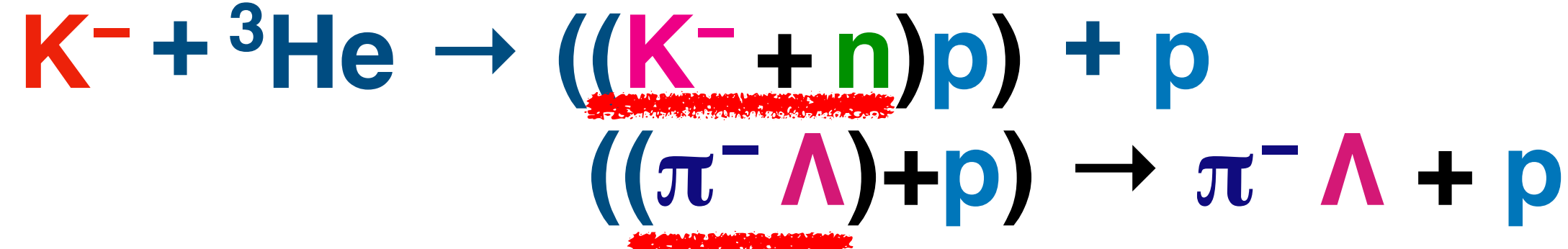

... but the *excess* is still not easy to see ... due to the *QF-K*

If $m_{\pi^- \Lambda} \geq m_{K^-} + m_n$, then the “ $K^- np$ ” bound state cannot be formed, but will form a quasi-free background.

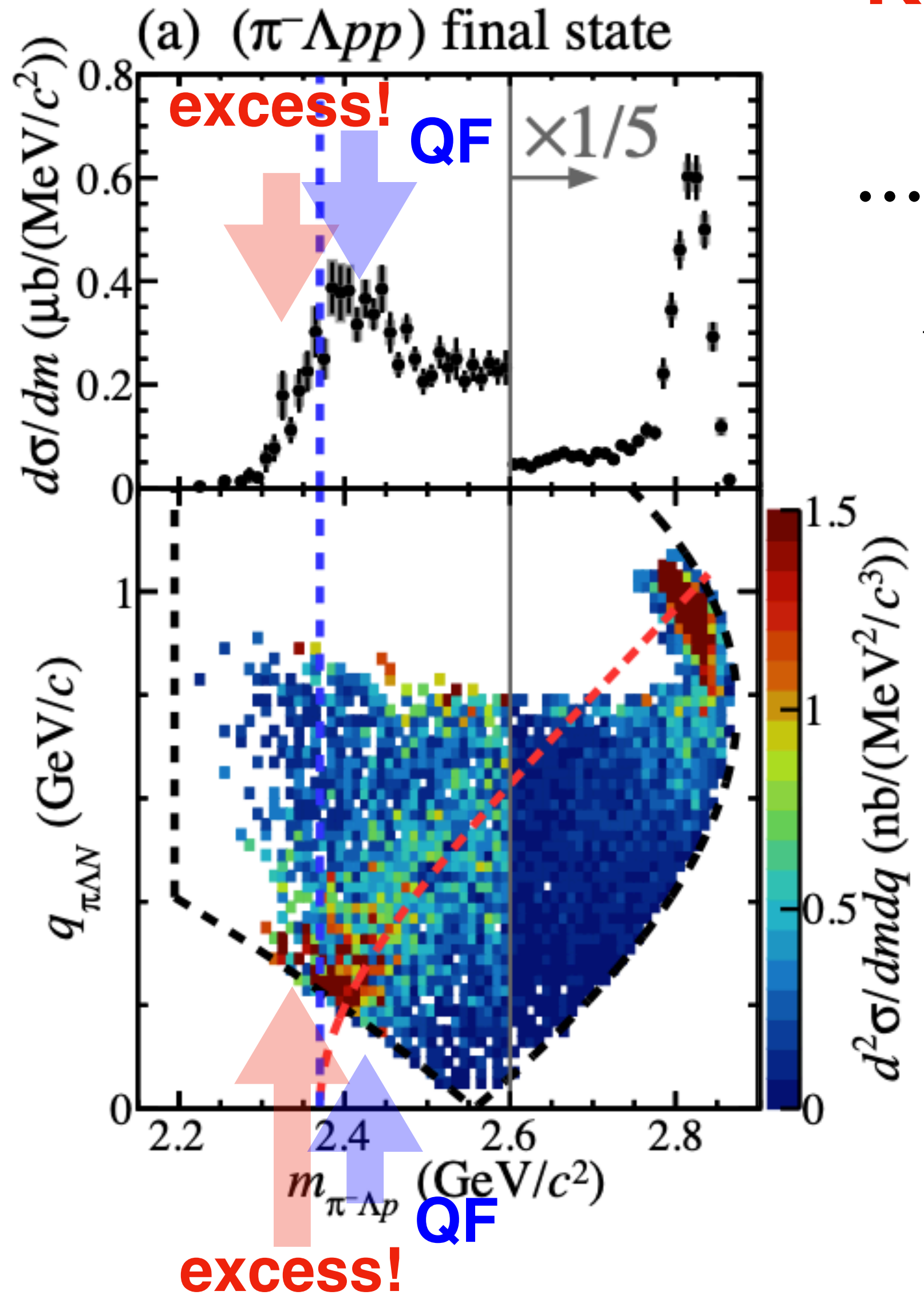

Mesonic decay branch of $\bar{K}^0 nn$?

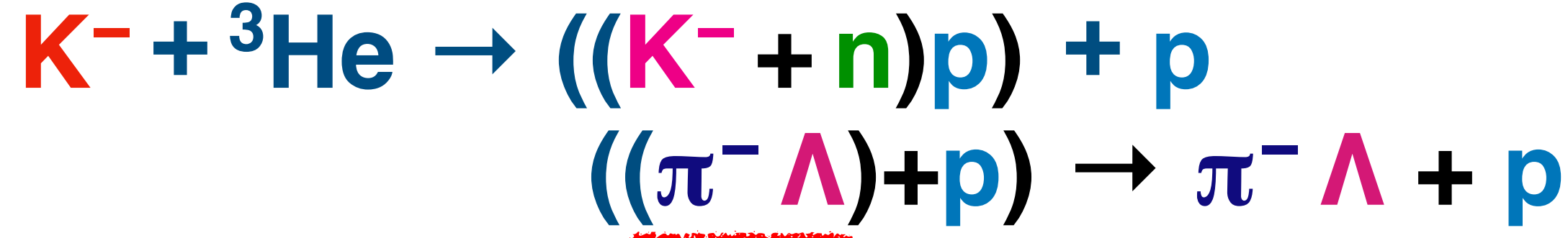

... but the *excess* is still not easy to see ... due to the *QF-K*

If $m_{\pi^- \Lambda} \geq m_{K^-} + m_n$, then the "*K⁻np*" bound state cannot be formed, but will form a quasi-free background.

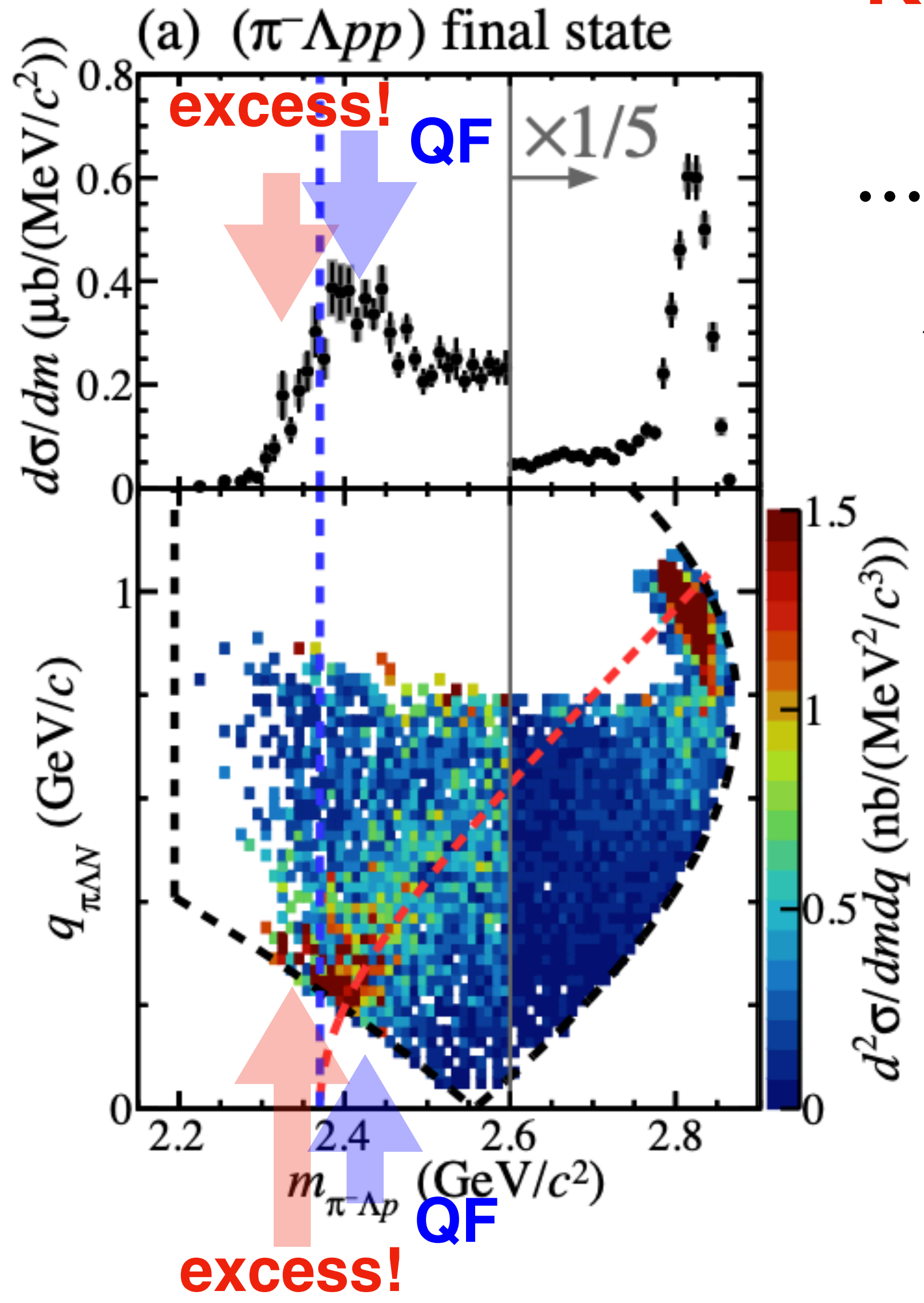

Mesonic decay branch of $\bar{K}^0 nn$?

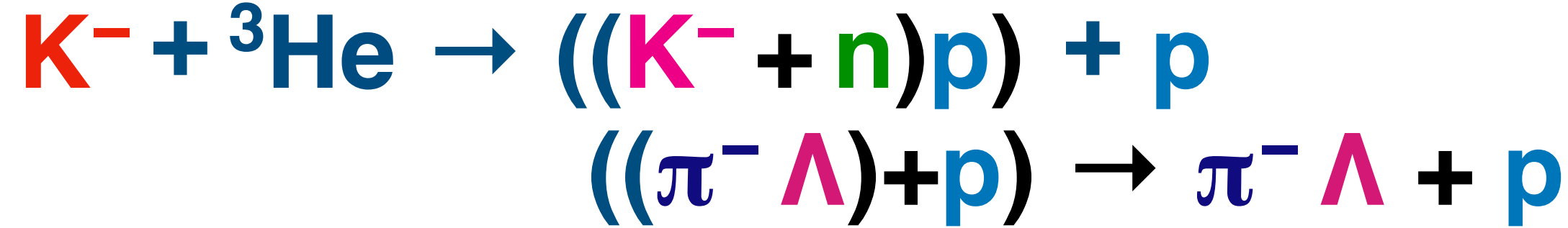

... but the *excess* is still not easy to see ... due to the *QF-K*

If $m_{\pi^- \Lambda} \geq m_{K^-} + m_n$, then the “*K⁻np*” bound state cannot be formed, but will form a quasi-free background.

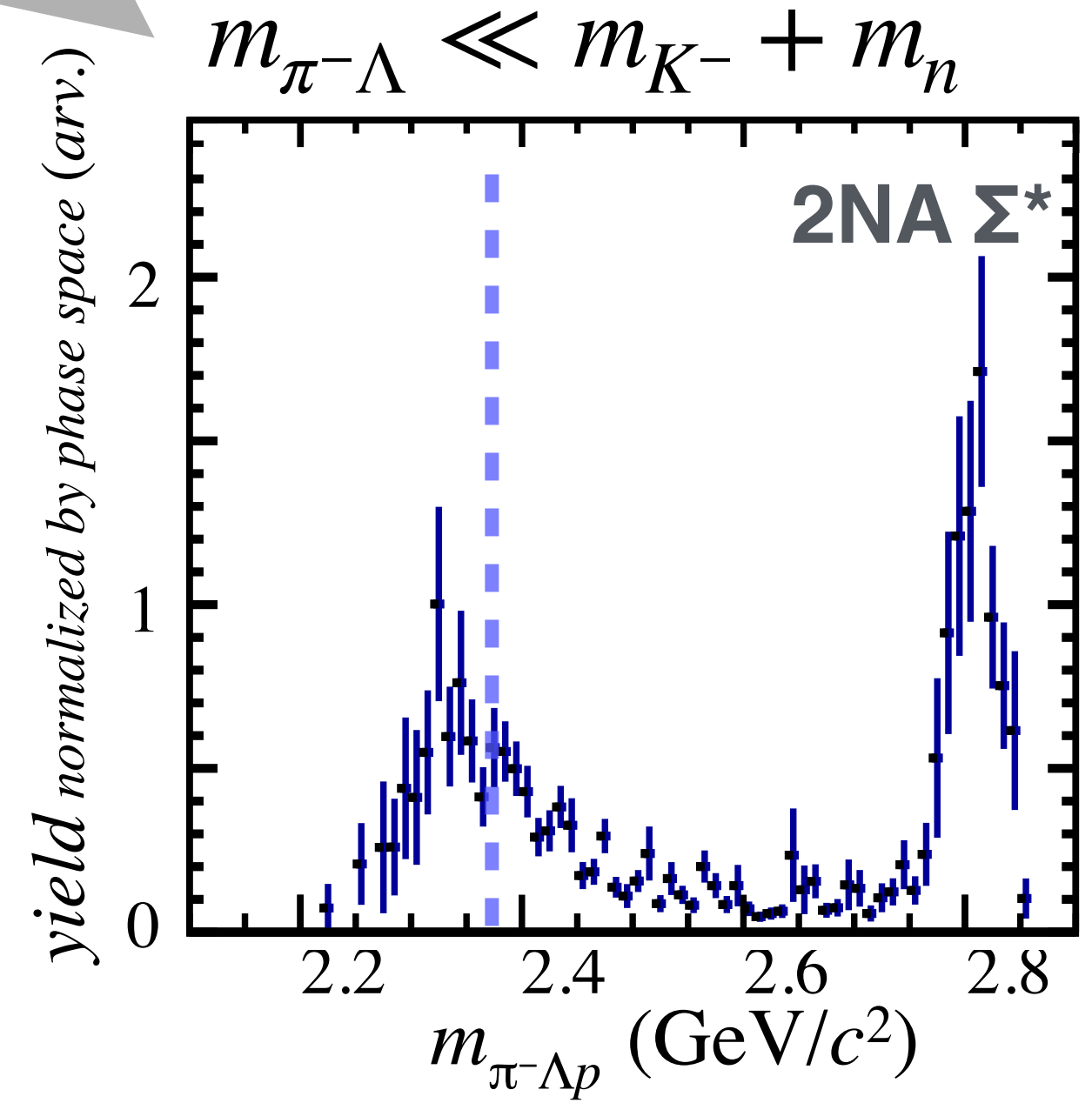
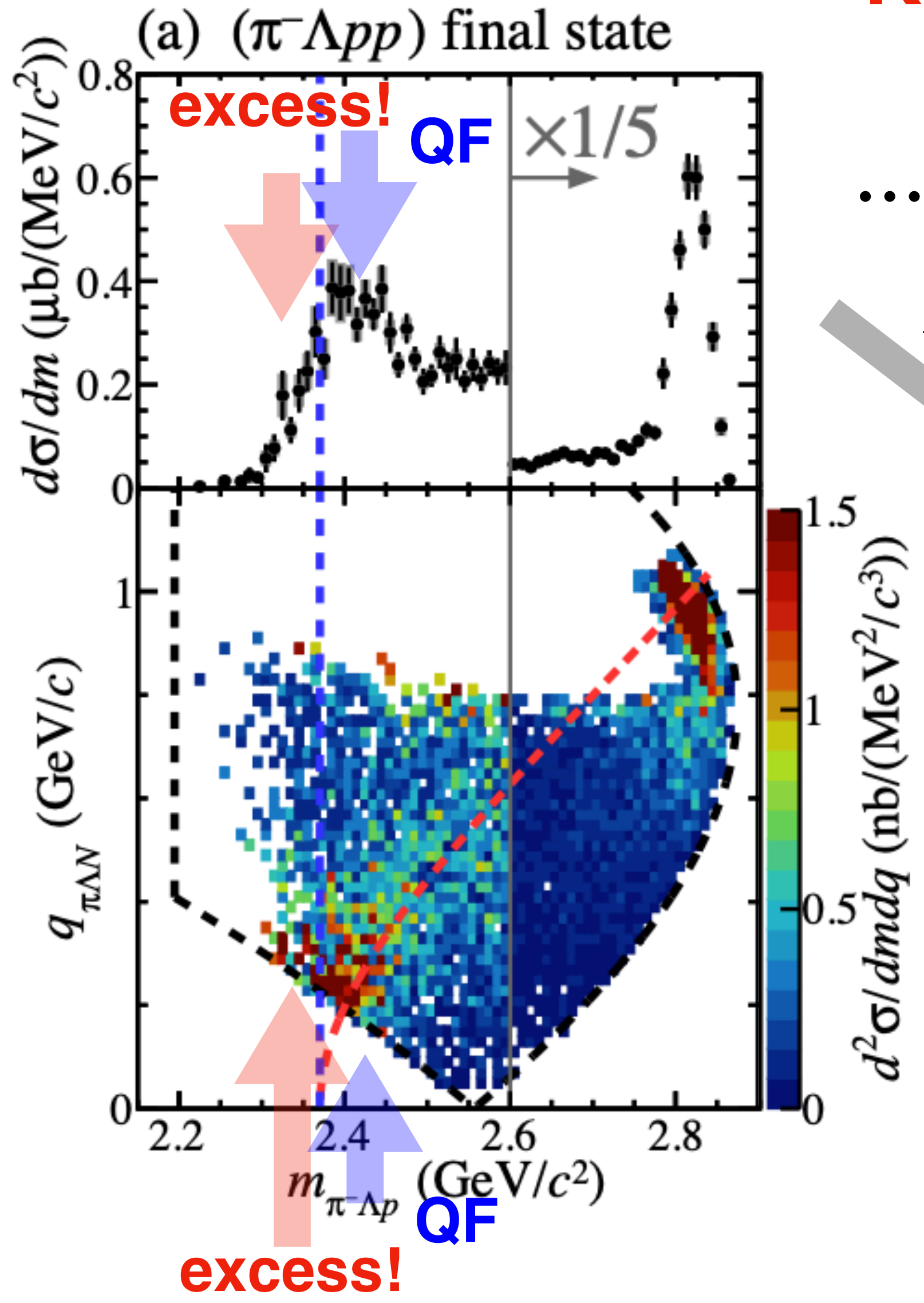

Mesonic decay branch of $\bar{K}^0 nn$?

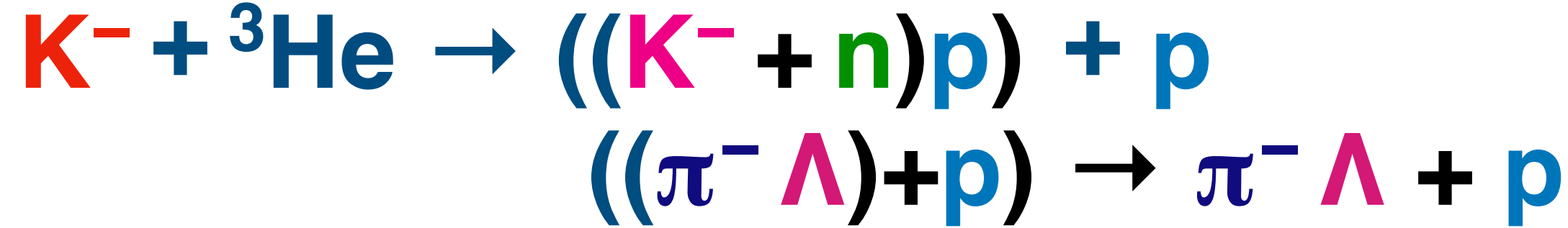

... but the *excess* is still not easy to see ... due to the *QF-K*

If $m_{\pi^- \Lambda} \geq m_{K^-} + m_n$, then the “ $K^- np$ ” bound state cannot be formed, but will form a quasi-free background.

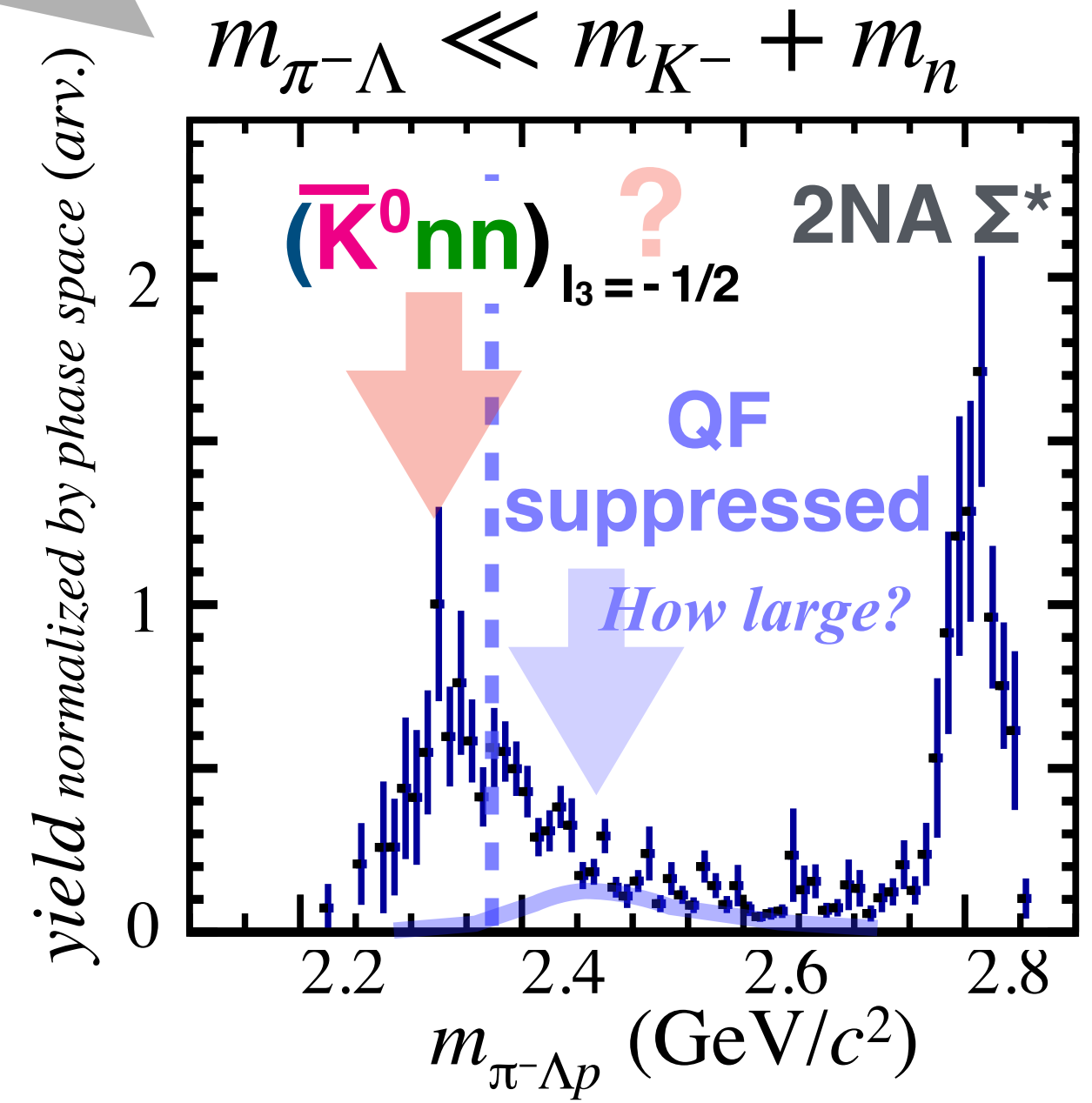
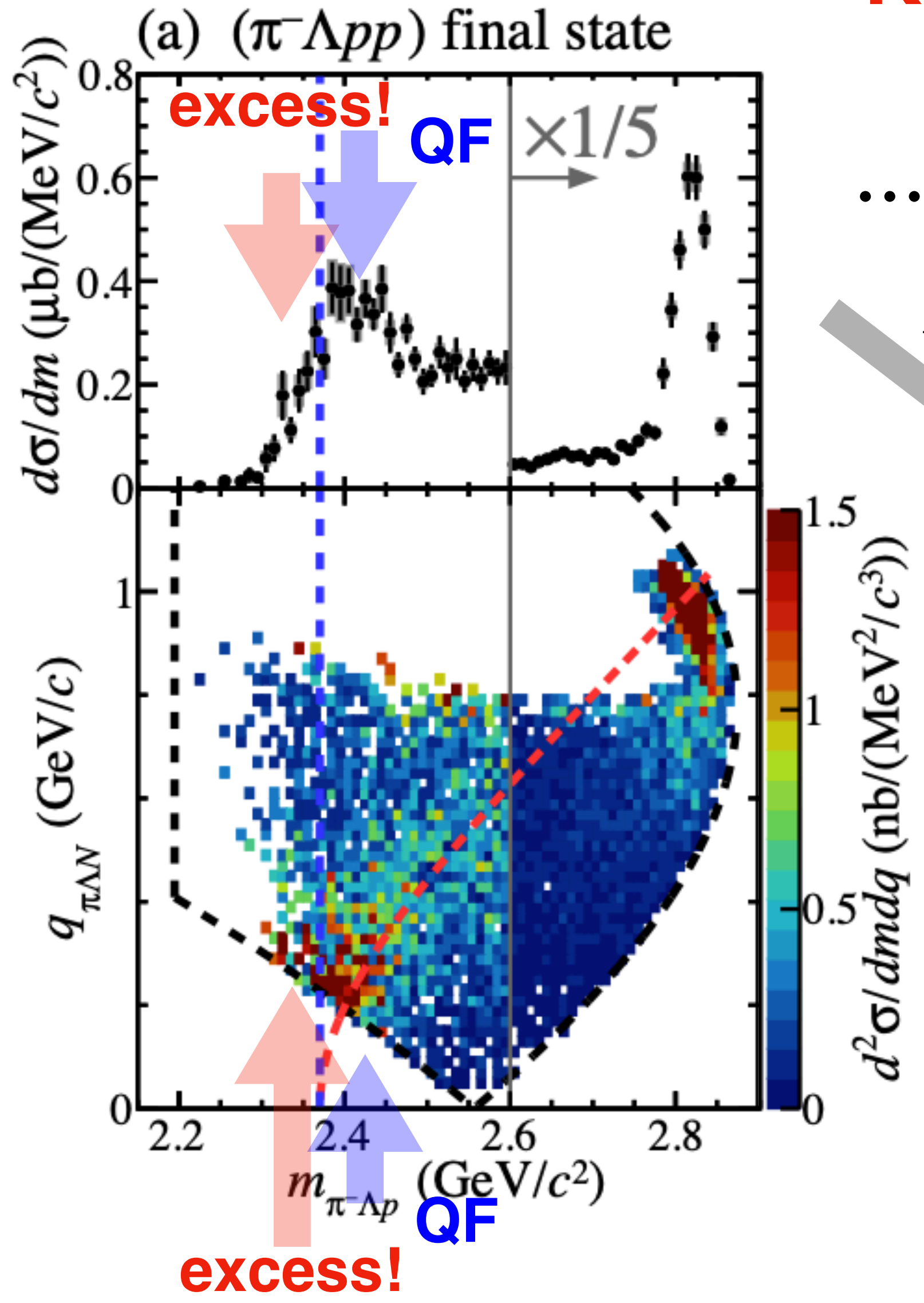

The spectrum is very promising, but needs further verification, by examining...

Mesonic decay branch of $\bar{K}^0 nn$?

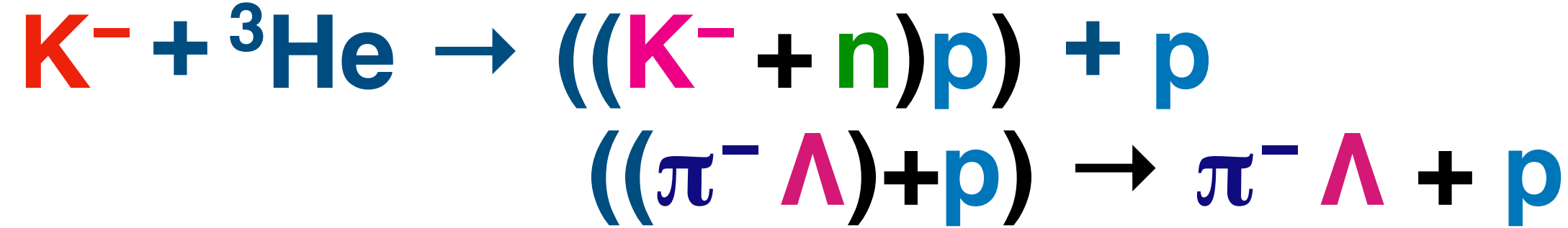

... but the *excess* is still not easy to see ... due to the *QF-K*

If $m_{\pi^- \Lambda} \geq m_{K^-} + m_n$, then the “ $K^- np$ ” bound state cannot be formed, but will form a quasi-free background.

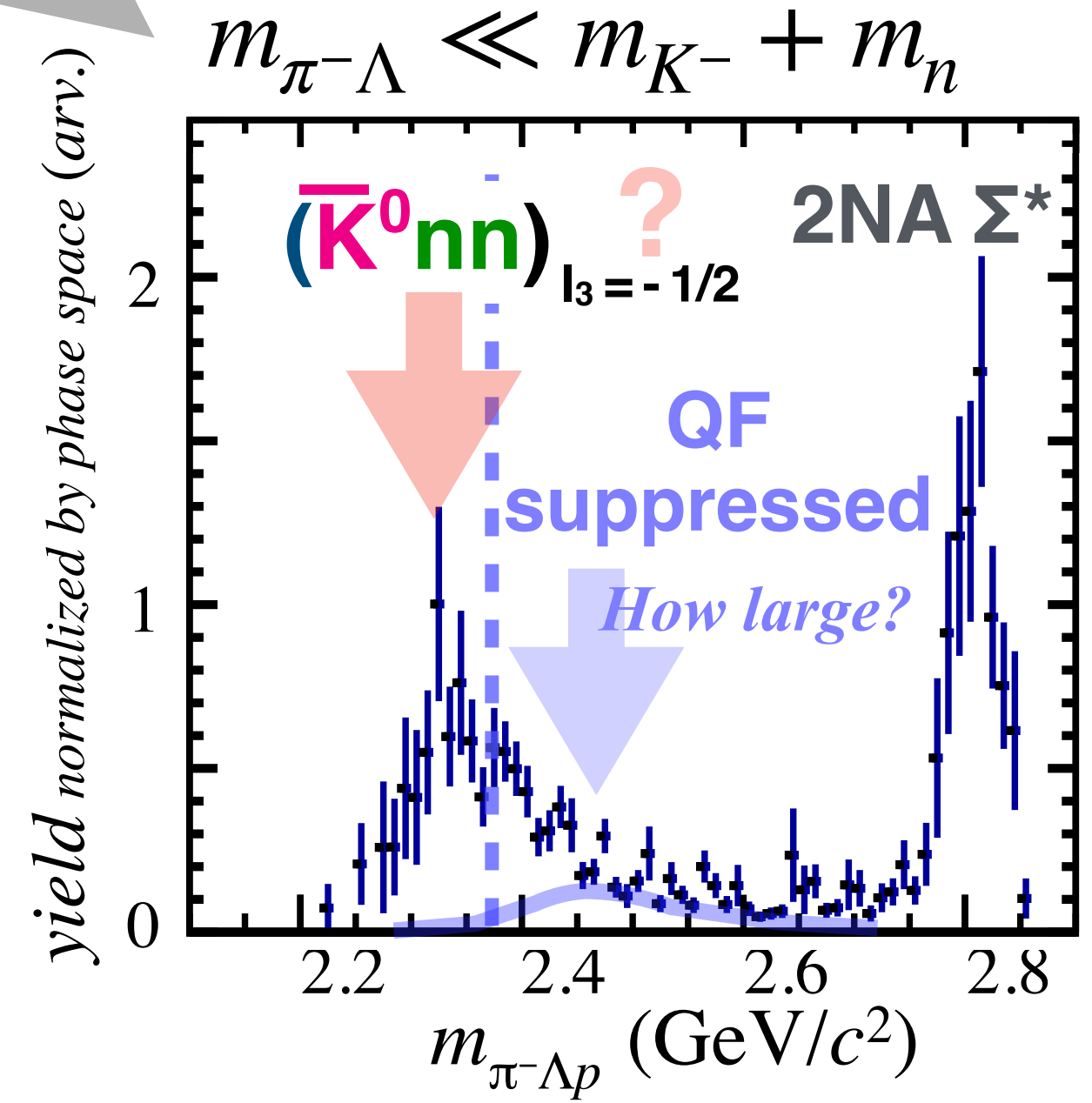
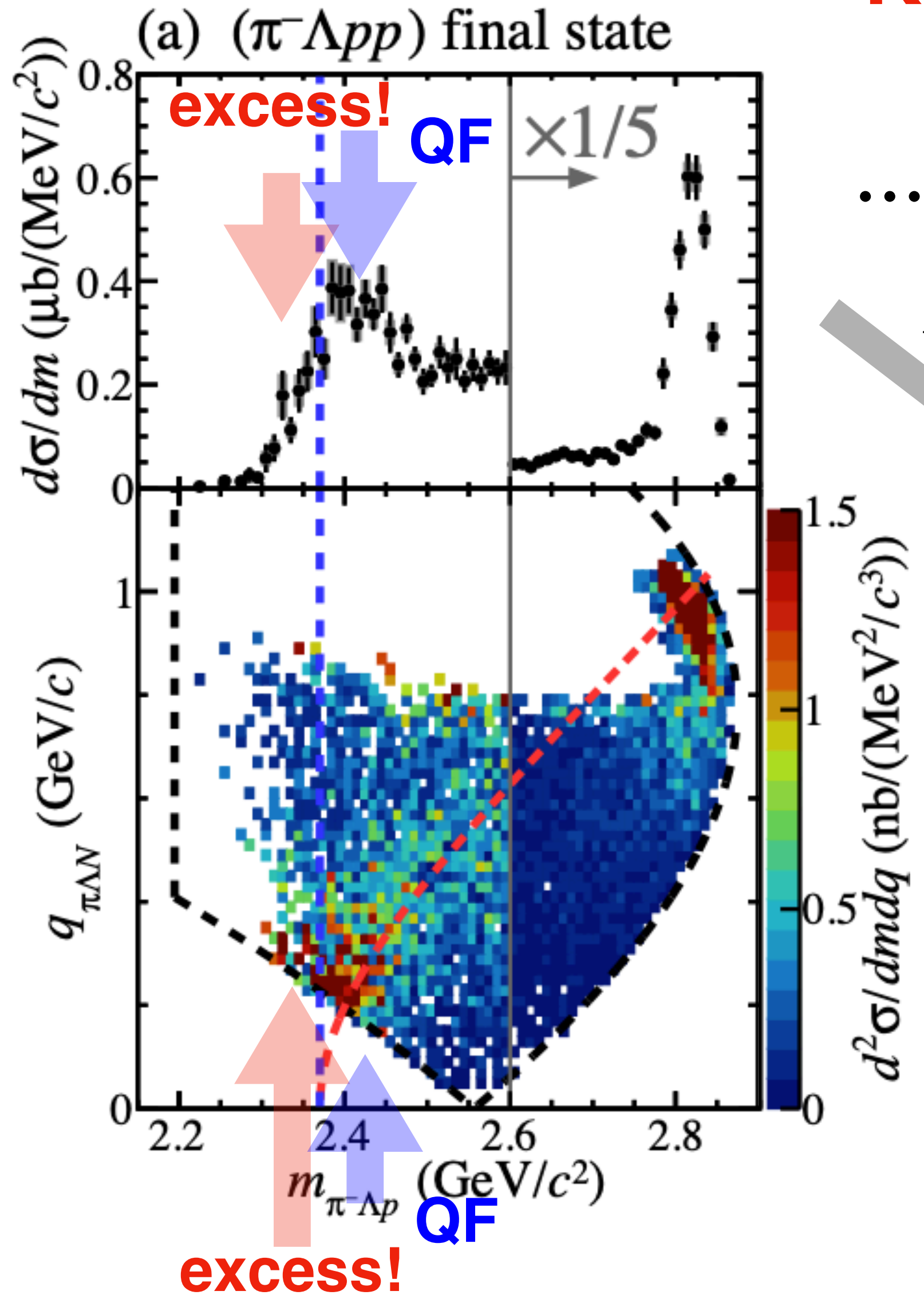

The spectrum is very promising, but needs further verification, by examining...

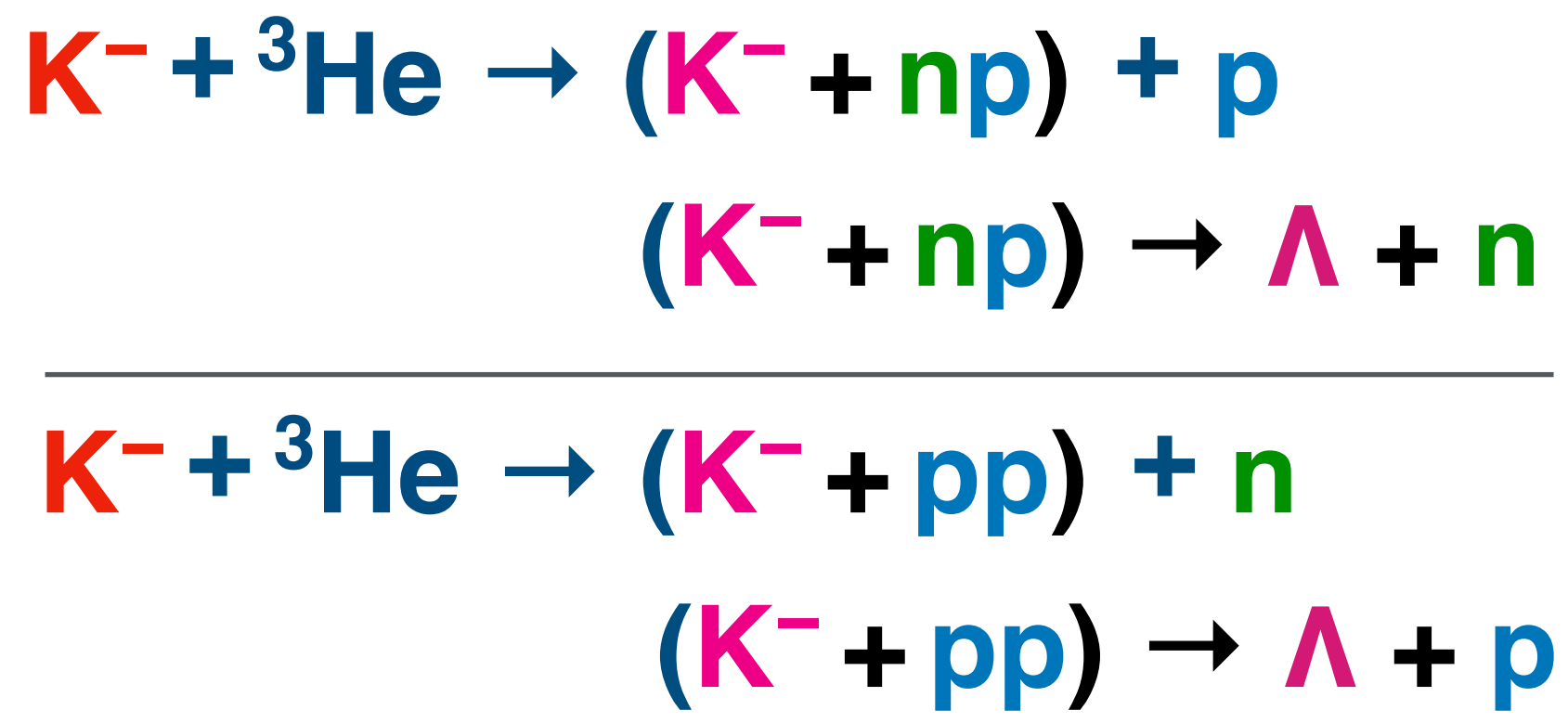

Mesonic decay branch of $\bar{K}^0 nn$?

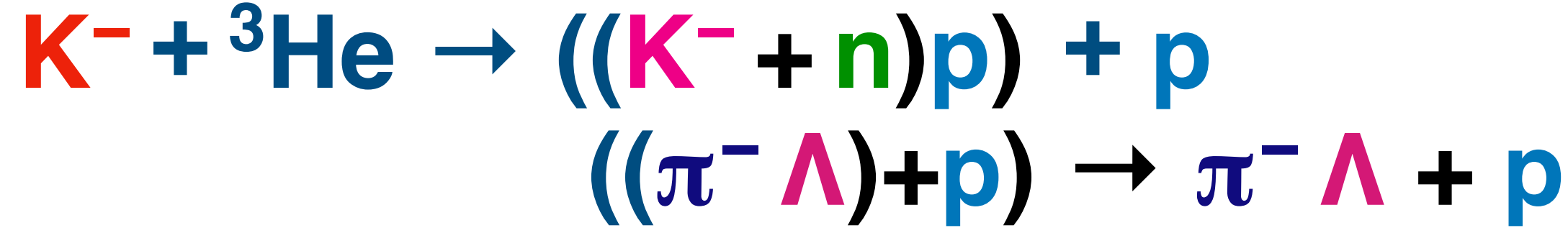

... but the *excess* is still not easy to see ... due to the *QF-K*

If $m_{\pi^- \Lambda} \geq m_{K^-} + m_n$, then the “ $K^- np$ ” bound state cannot be formed, but will form a quasi-free background.

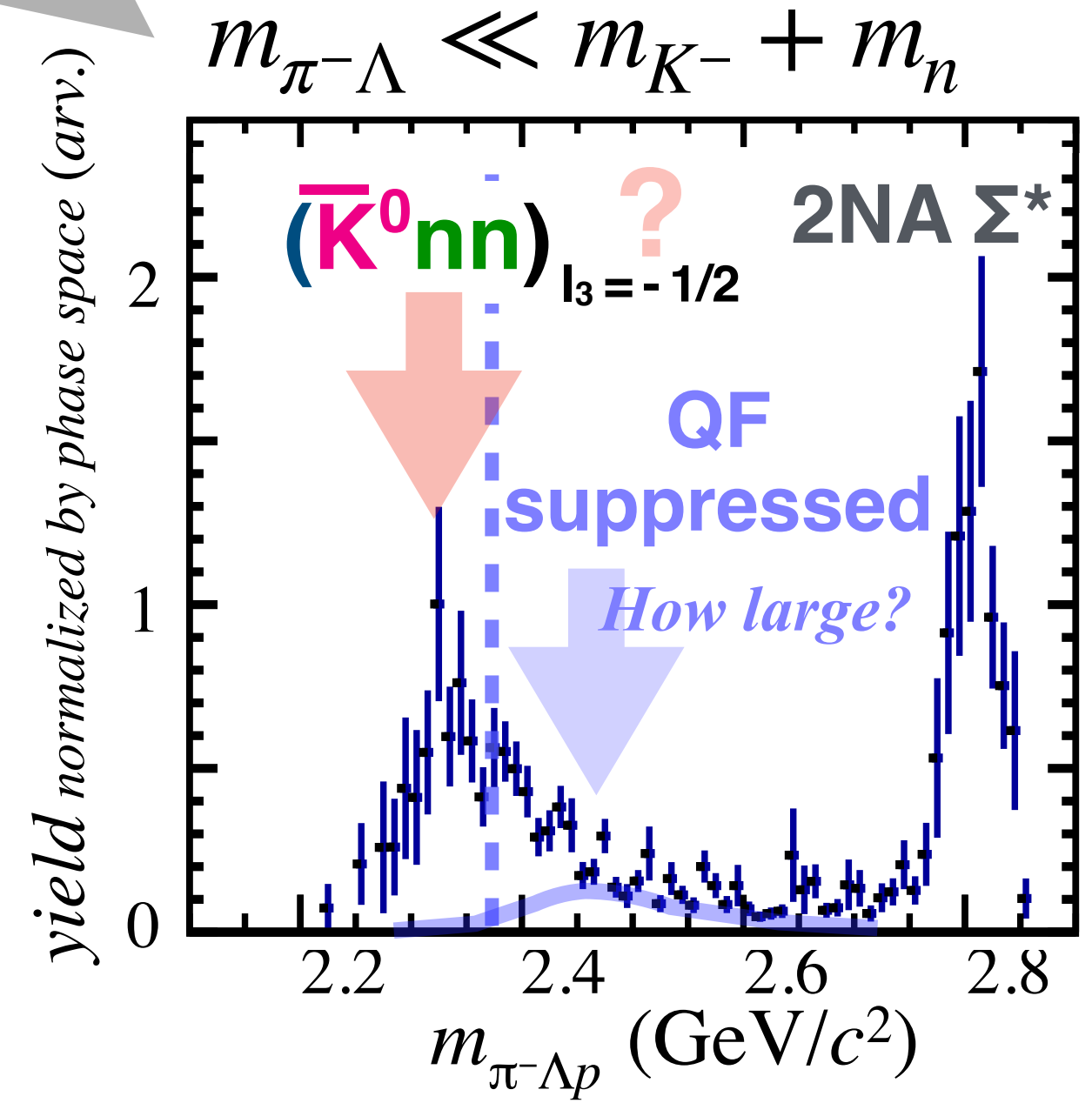
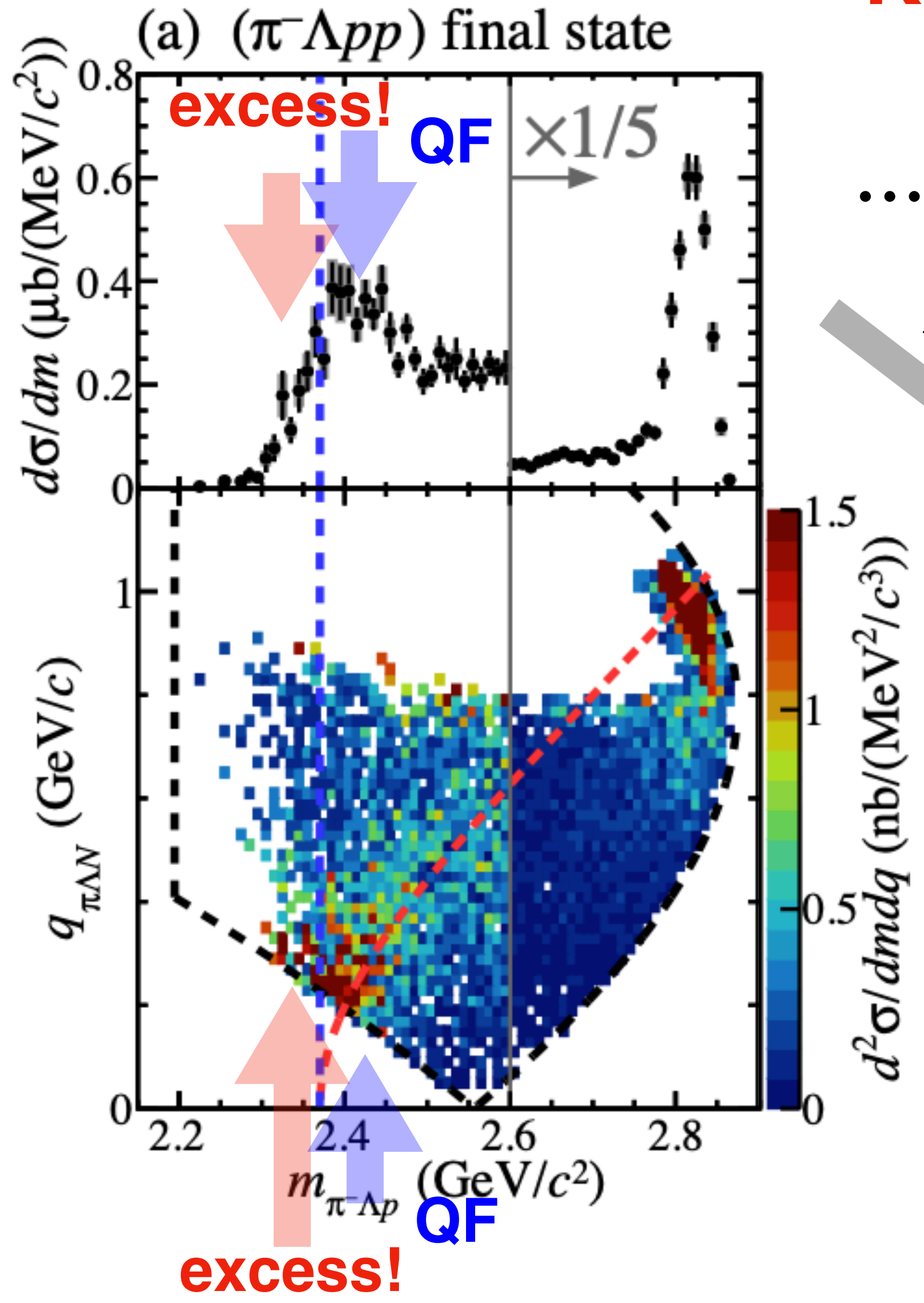

The spectrum is very promising, but needs further verification, by examining...

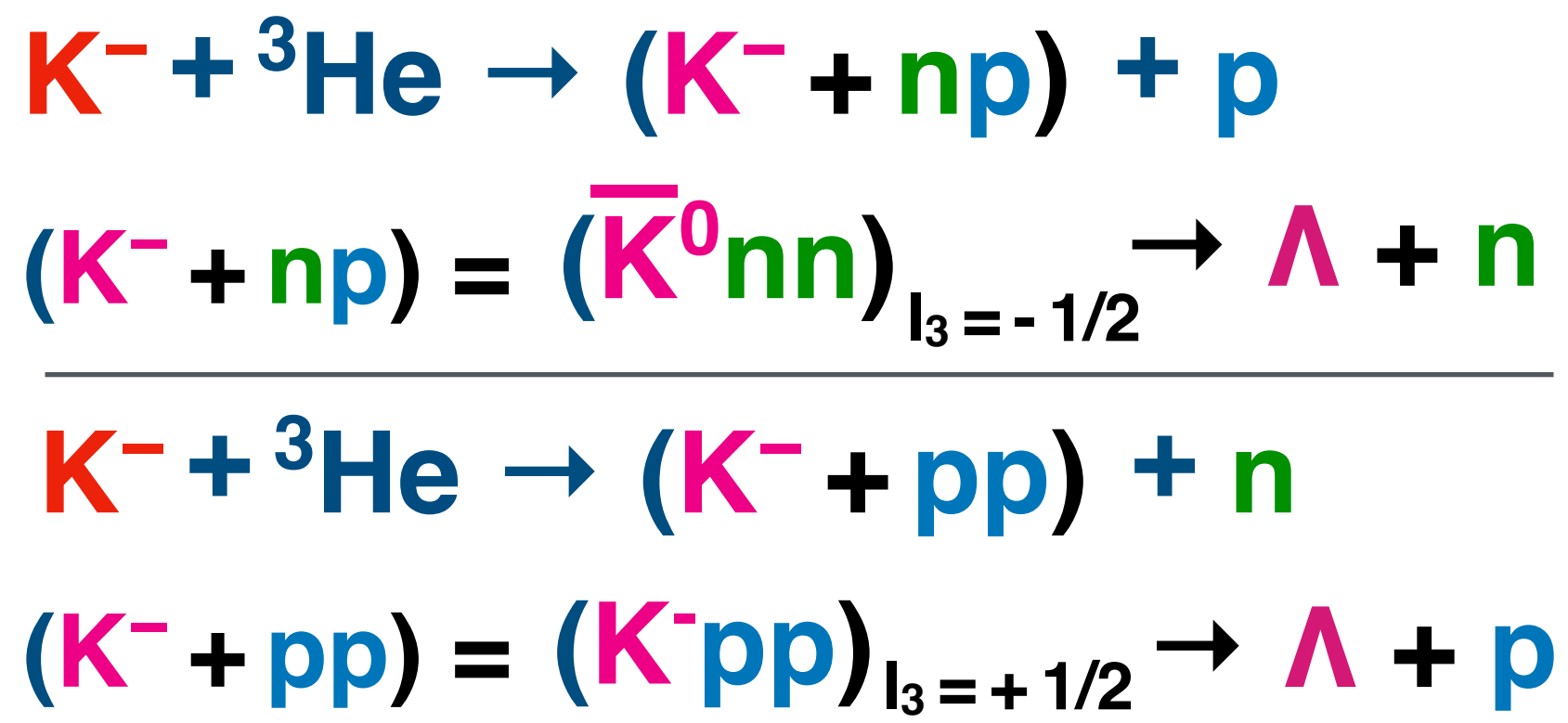

Signal of $\bar{K}NNN$?

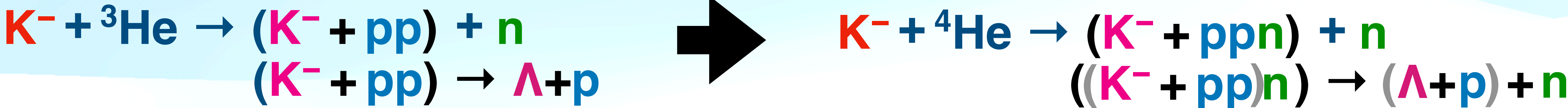

Preliminary data analysis for $\bar{K}NNN$ formation study utilizing ${}^4_{\Lambda}\text{He}$ lifetime measurement via $K^- + {}^4\text{He} \rightarrow \pi^0 + {}^4_{\Lambda}\text{He}$ reaction giving us a very interesting result

Signal of $\bar{K}NNN$?

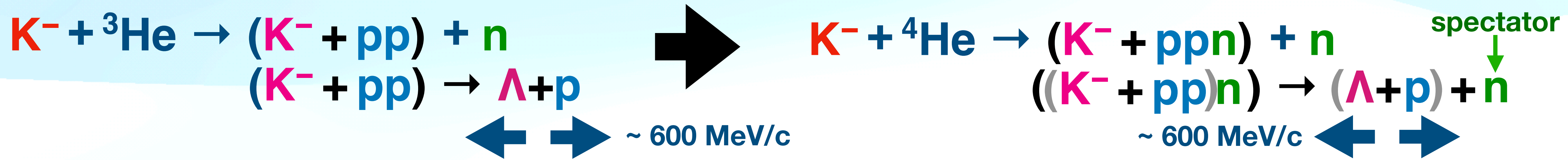

Preliminary data analysis for $\bar{K}NNN$ formation study utilizing ${}^4_{\Lambda}\text{He}$ lifetime measurement via $K^- + {}^4\text{He} \rightarrow \pi^0 + {}^4_{\Lambda}\text{He}$ reaction giving us a very interesting result

Signal of $\bar{K}NNN$?



Preliminary data analysis for $\bar{K}NNN$ formation study utilizing ${}^4_{\Lambda}\text{He}$ lifetime measurement via $K^- + {}^4\text{He} \rightarrow \pi^0 + {}^4_{\Lambda}\text{He}$ reaction giving us a very interesting result

Signal of $\bar{K}NNN$?

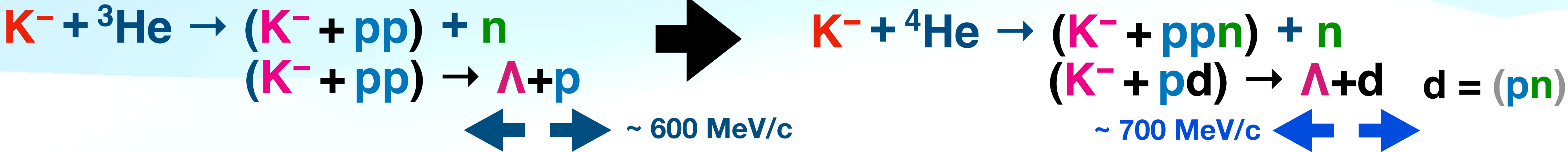

Preliminary data analysis for $\bar{K}NNN$ formation study utilizing ${}^4_{\Lambda}\text{He}$ lifetime measurement via $K^- + {}^4\text{He} \rightarrow \pi^0 + {}^4_{\Lambda}\text{He}$ reaction giving us a very interesting result

$K^- 4\text{He} \rightarrow \{\Lambda d\} + n$ Analysis (with the T77 Data)

Promising signal is observed!

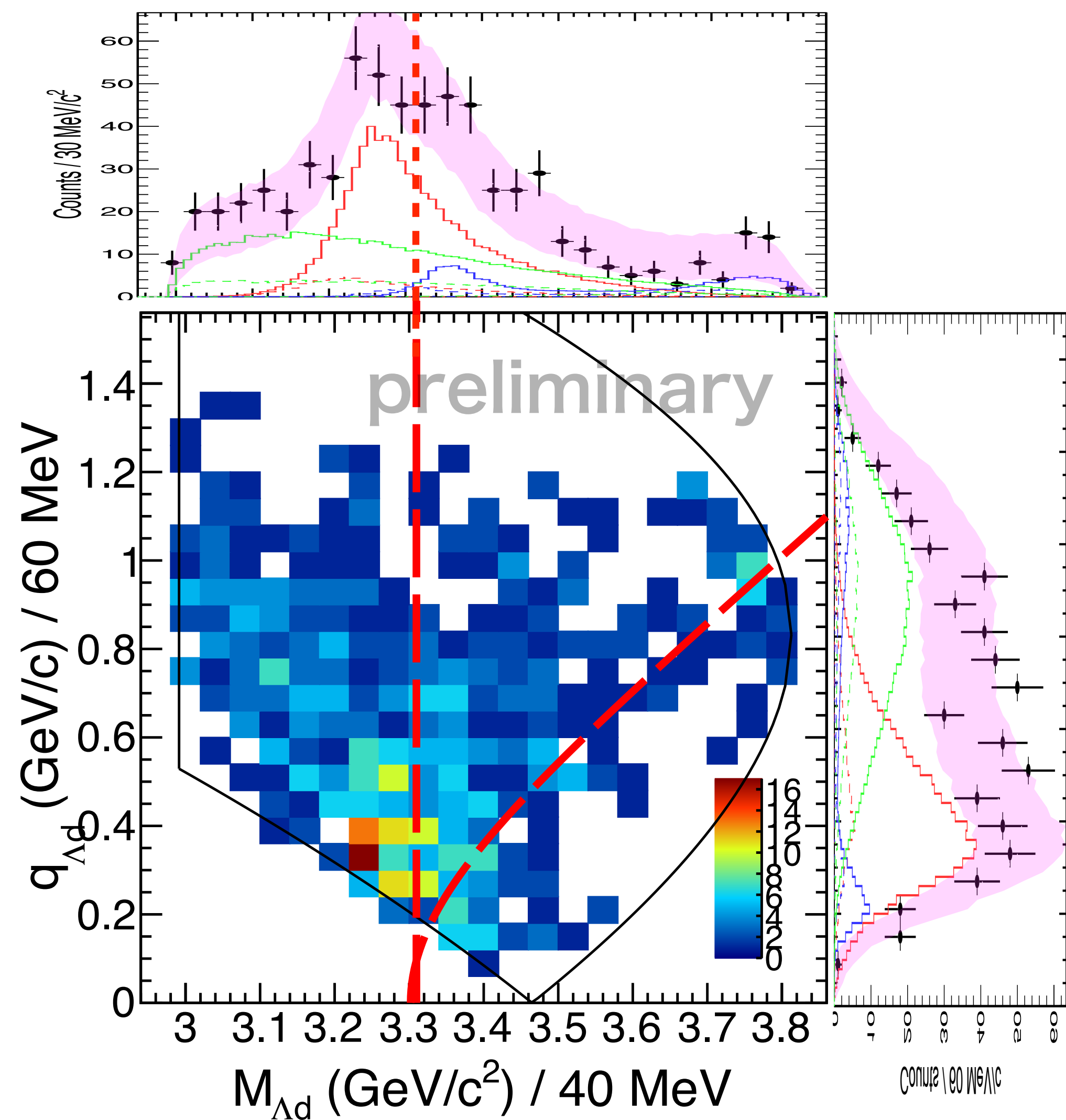

$K^- ^4\text{He} \rightarrow \{\Lambda d\} + n$ Analysis (with the T77 Data)

Promising signal is observed!

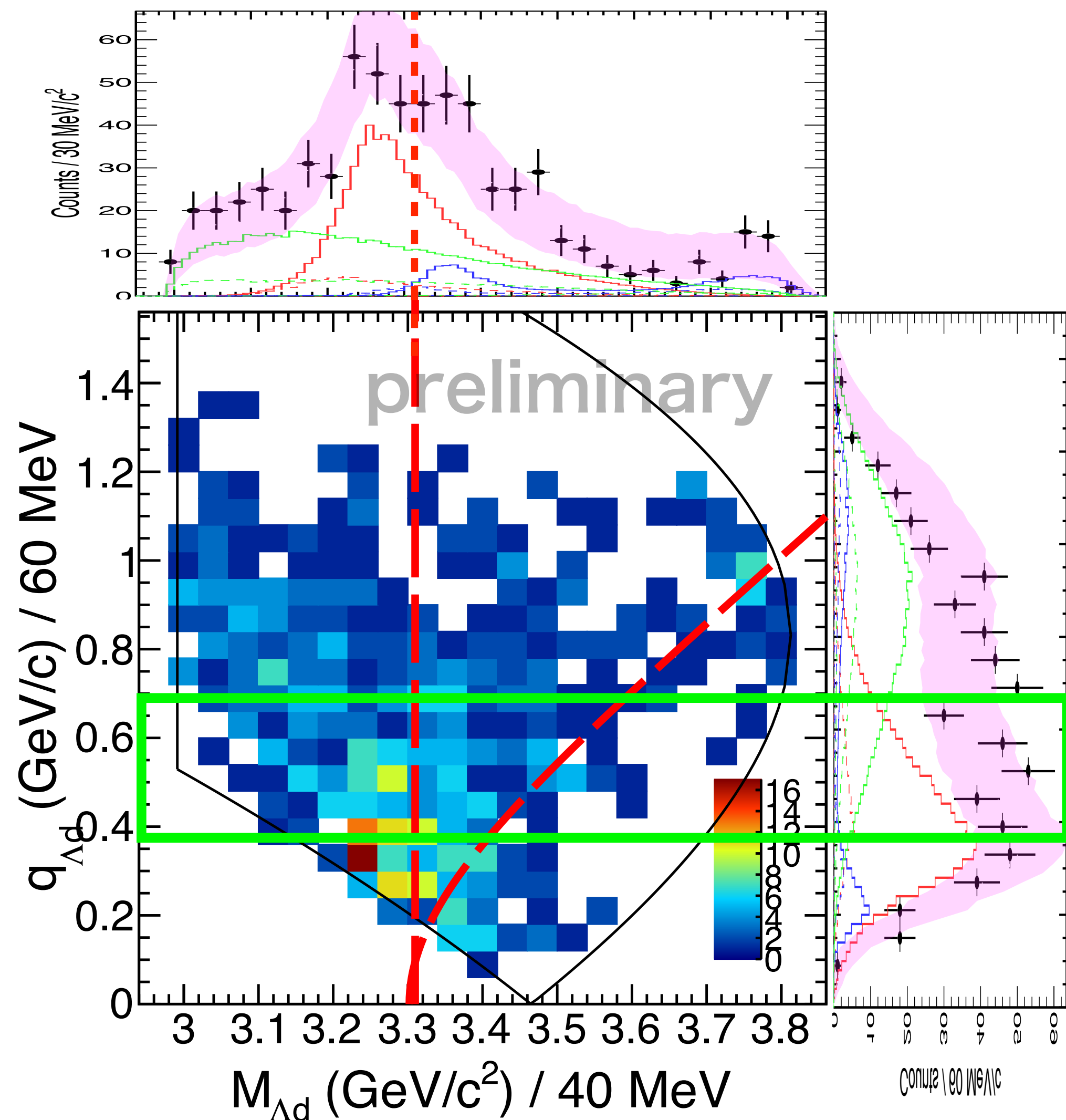

$0.3 < q_{\Lambda d} < 0.6$
GeV/c window

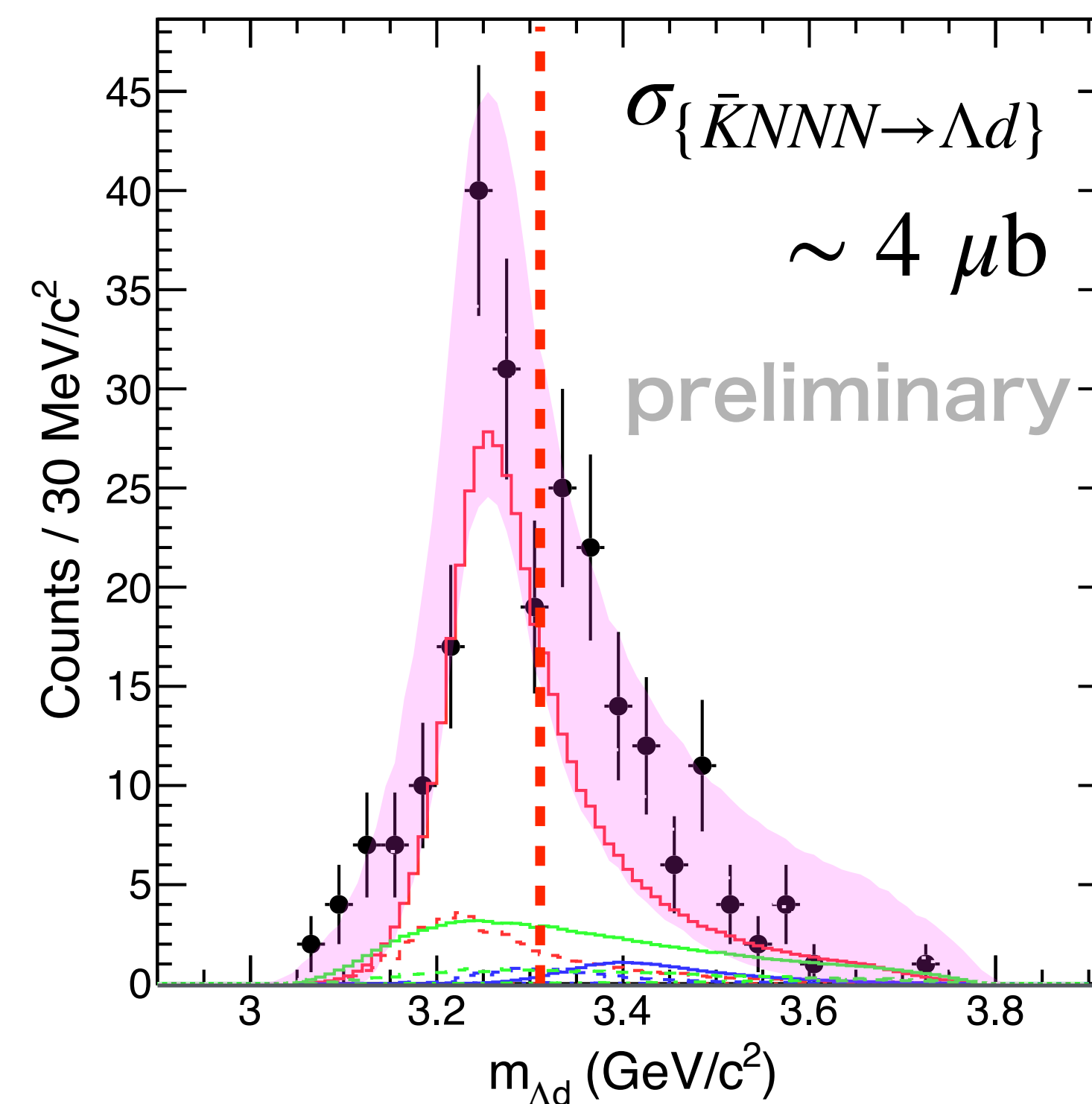

$K^- {}^4\text{He} \rightarrow \{\Lambda d\} + n$ Analysis (with the T77 Data)

Promising signal is observed! 1) *It suggests kaonic nuclei exist more universally, not just in cases like $K^- pp$.*

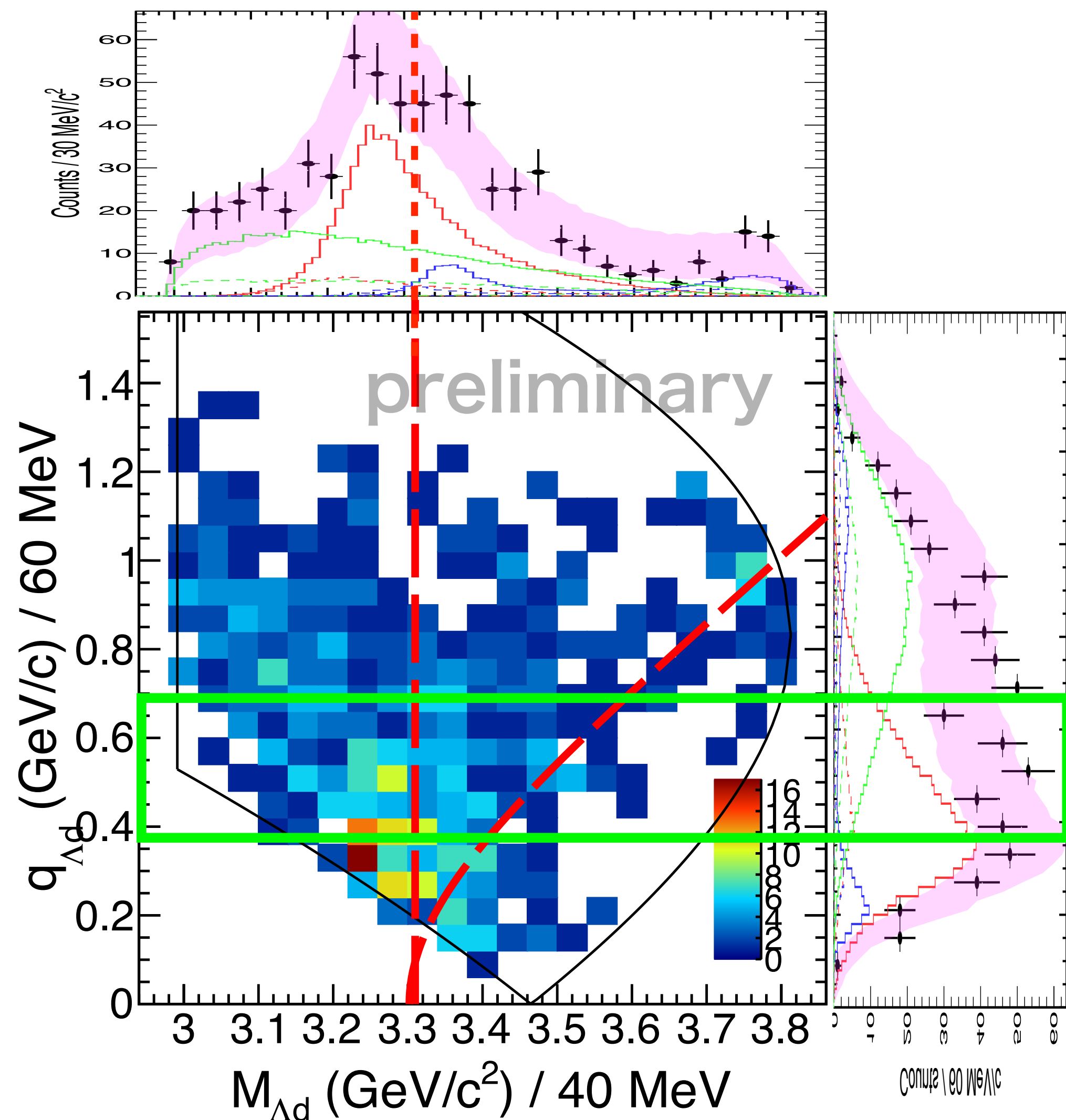

$0.3 < q_{\Lambda d} < 0.6$
GeV/c window

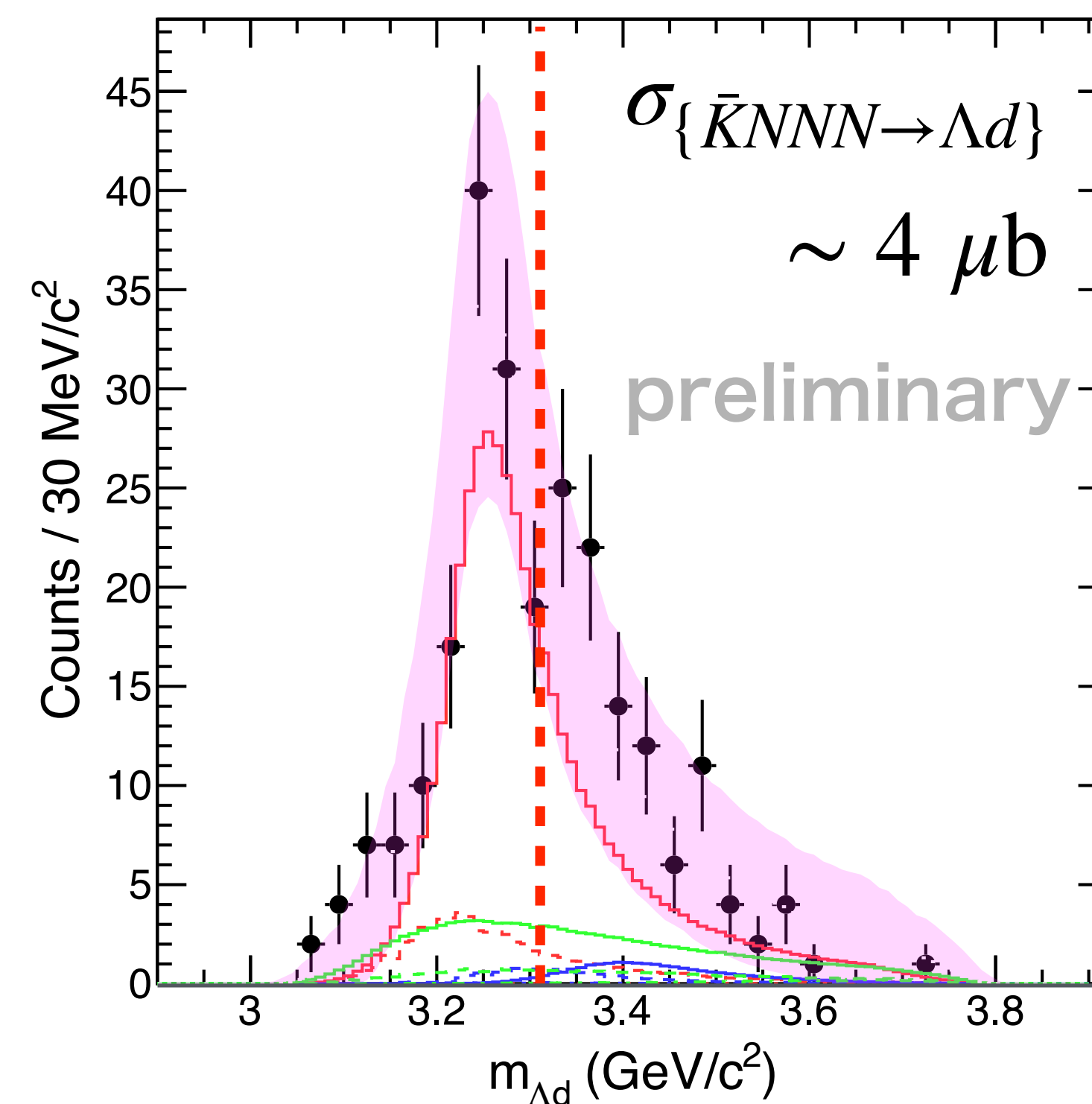

$K^- {}^4\text{He} \rightarrow \{\Lambda d\} + n$ Analysis (with the T77 Data)

- Promising signal is observed!**
- 1) It suggests kaonic nuclei exist more universally, not just in cases like $K^- pp$.
 - 2) Despite more nucleons absorbing the K meson, the width remains unchanged, suggesting a near plateau.

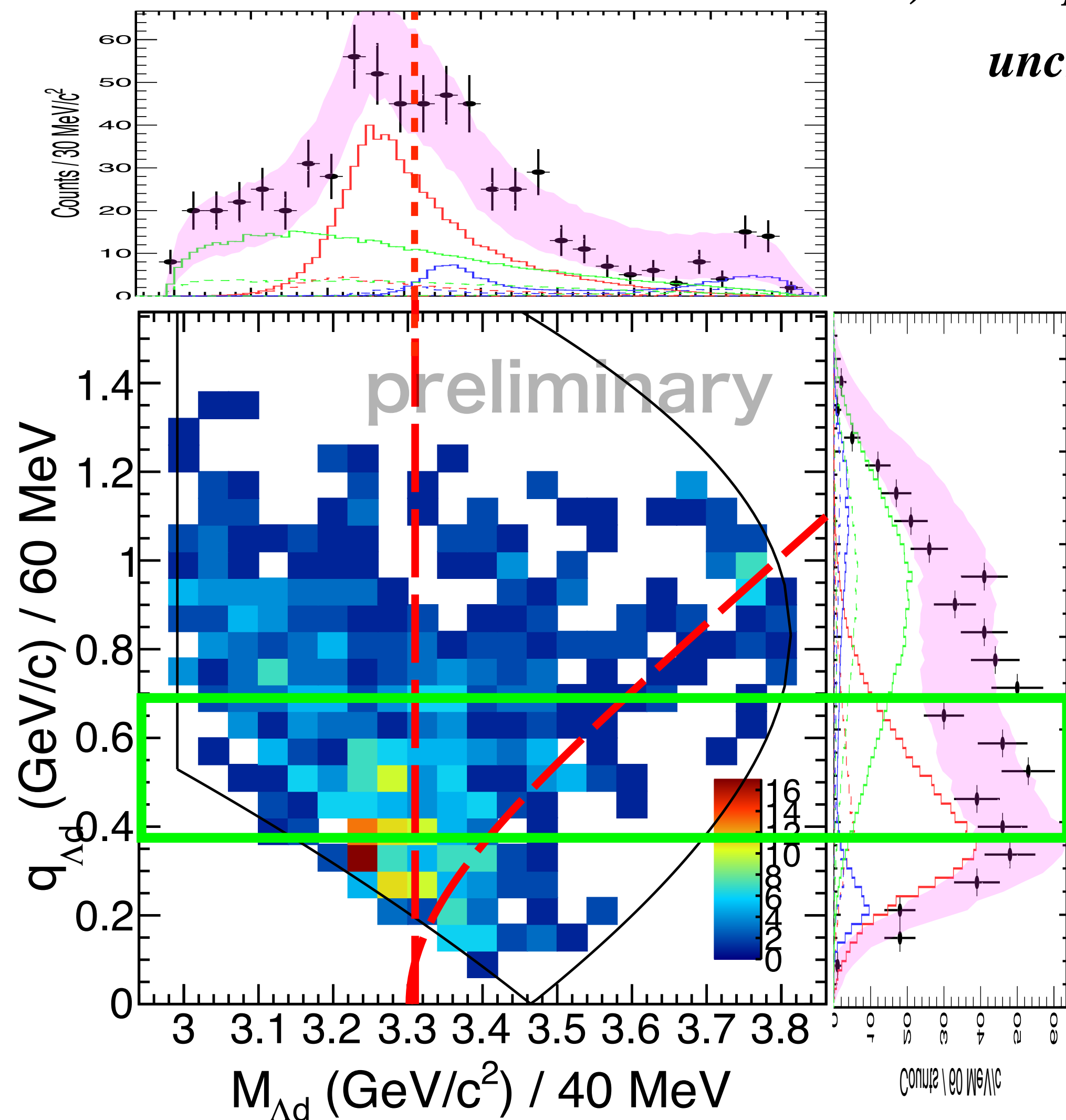

$0.3 < q_{\Lambda d} < 0.6$
GeV/c window

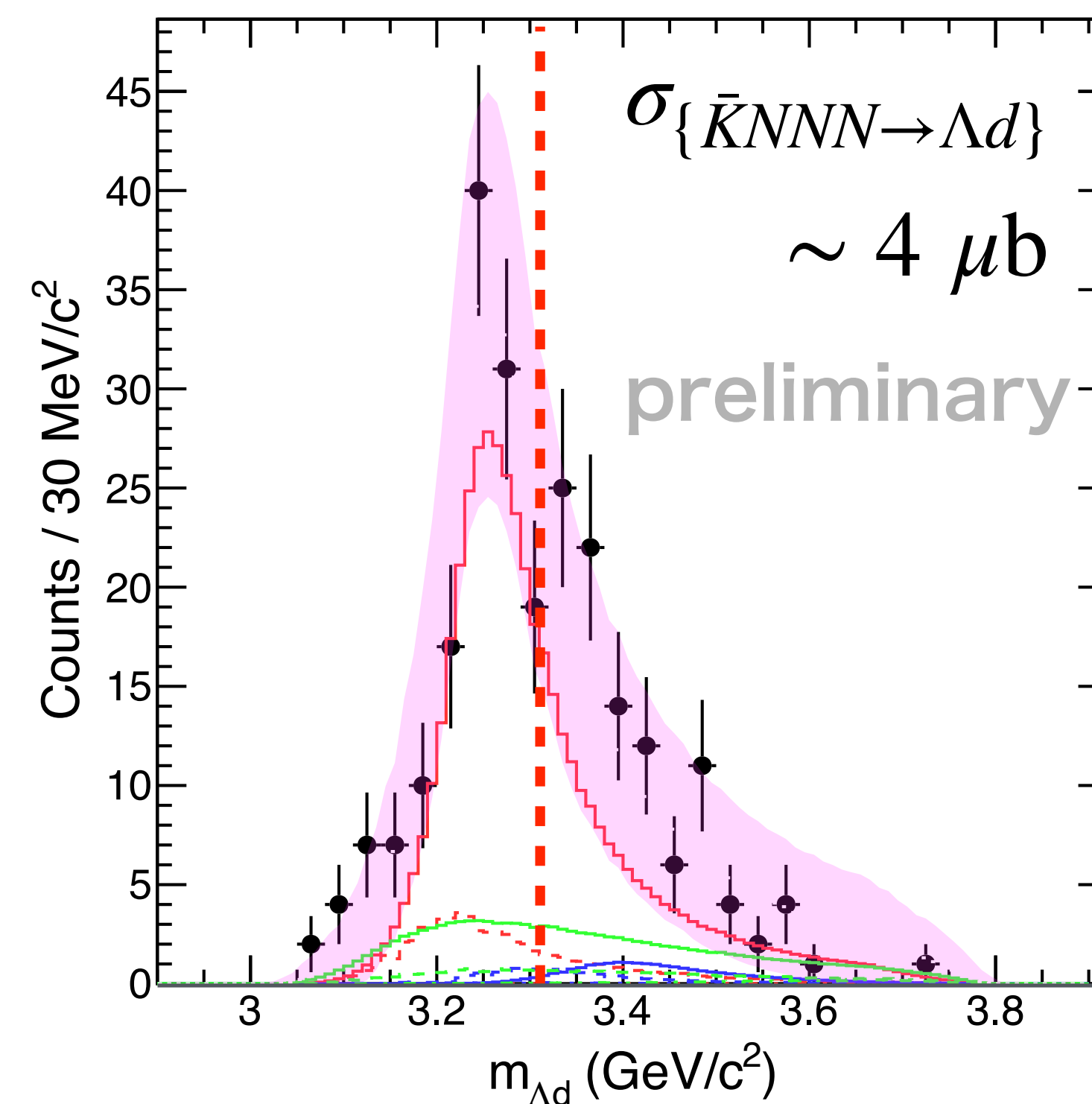

$K^- {}^4\text{He} \rightarrow \{\Lambda d\} + n$ Analysis (with the T77 Data)

Promising signal is observed!

- 1) It suggests kaonic nuclei exist more universally, not just in cases like $K^- pp$.
- 2) Despite more nucleons absorbing the K meson, the width remains unchanged, suggesting a near plateau.
- 3) In the case of $K^- ppn$, isospin and spin-parity $I(J^P)$, has been fixed to be $0(1/2^-)$ with high certainty through Λp decay.

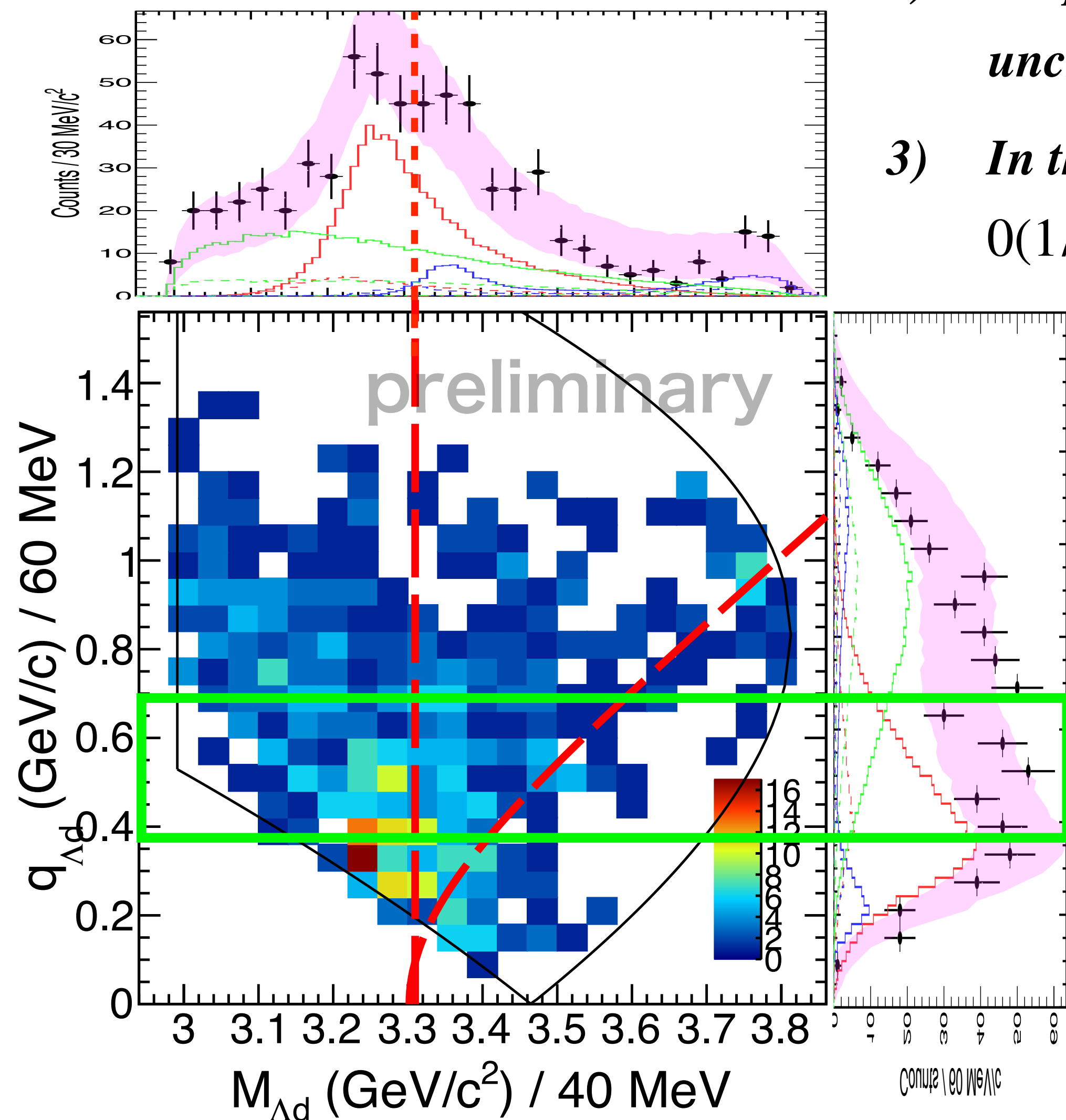

$0.3 < q_{\Lambda d} < 0.6$
GeV/c window

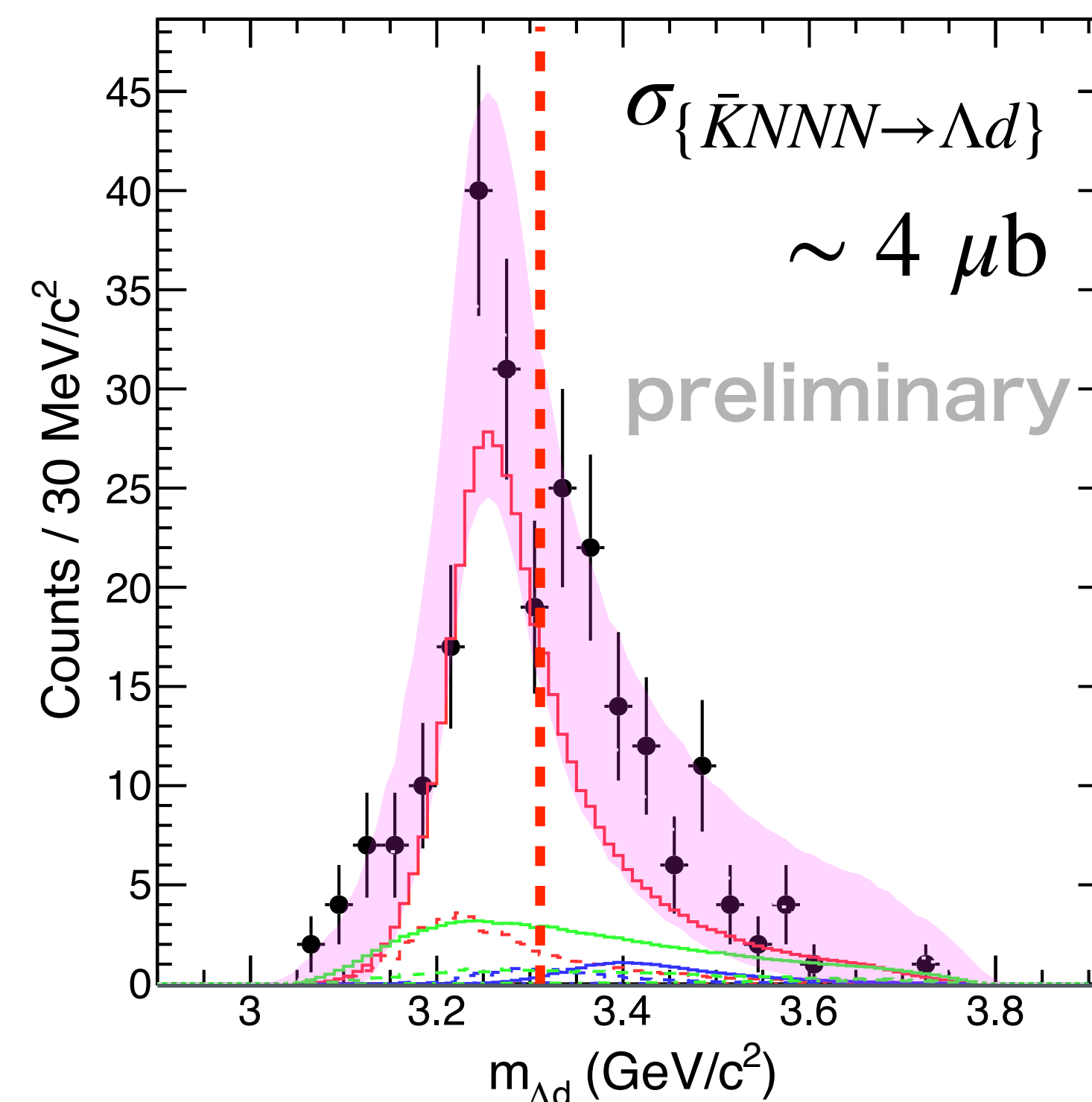

$I(J^P)$ of X in $K^- 4\text{He} \rightarrow X + n$

What is the $I(J^P)$ of the observed state? := $0(1/2^-)$

➤ $\Lambda p n$ would be the major decay mode (relatively easily identified in this channel)

1. “ X ” $\rightarrow \Lambda d$ decay mode is unique evidence of $I_{“X”} = 0$

- $I(J^P) : \Lambda = 0(1/2^+), d = 0(1^+), K^- = 1/2(0^-), {}^3\text{He} = 1/2(1/2^+), {}^4\text{He} = 0(0^+)$

$I(J^P)$ of X in $K^- 4\text{He} \rightarrow X + n$

What is the $I(J^P)$ of the observed state? := $0(1/2^-)$

➤ Λpn would be the major decay mode (relatively easily identified in this channel)

1. “ X ” $\rightarrow \Lambda d$ decay mode is unique evidence of $I_{“X”} = 0$

- $I(J^P) : \Lambda = 0(1/2^+), d = 0(1^+), K^- = 1/2(0^-), {}^3\text{He} = 1/2(1/2^+), {}^4\text{He} = 0(0^+)$

2. If “ X ” = “ $K^- ppn$ ”, then J would be $J_{Kppn} = 1/2$, because J_{NNN}

must be $1/2$ (two nucleons out of three are identical).

- **Most likely, it is “ X ” = “ $K^- ppn$ ”,** in which \bar{K} 's isospin anti-parallel coupling with NNN [$I(J) = 1/2(1/2)$] in S-wave
- **Difficult to interpret as $\Sigma^* NN$:** 1) spin/isospin of NN [$I(J) = 1(0)$] part must flip to form deuteron [$I(J) = 0(1)$], and 2) energy release is much bigger than the binding energy of d .

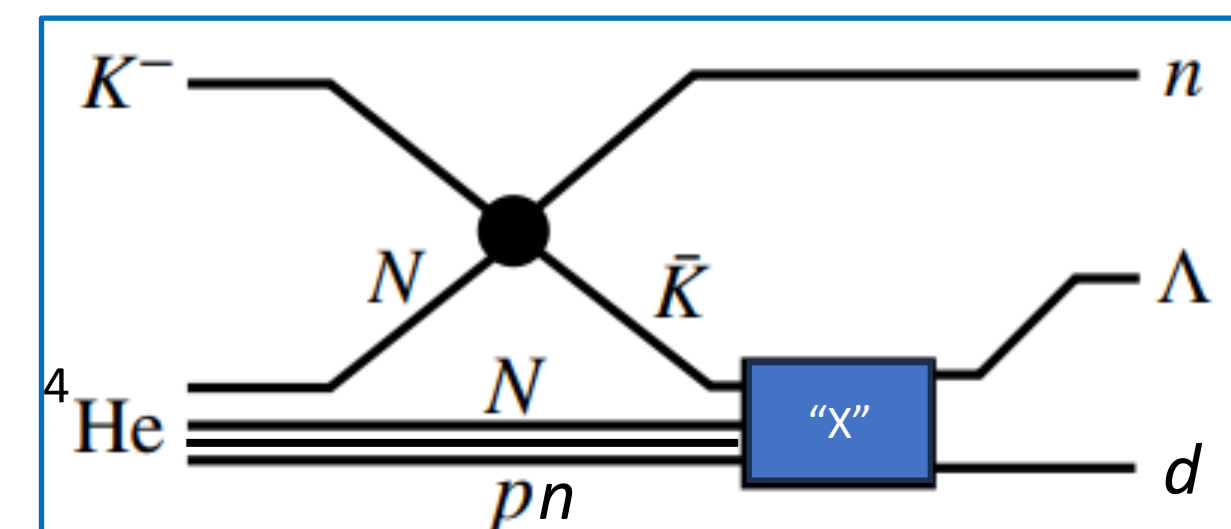
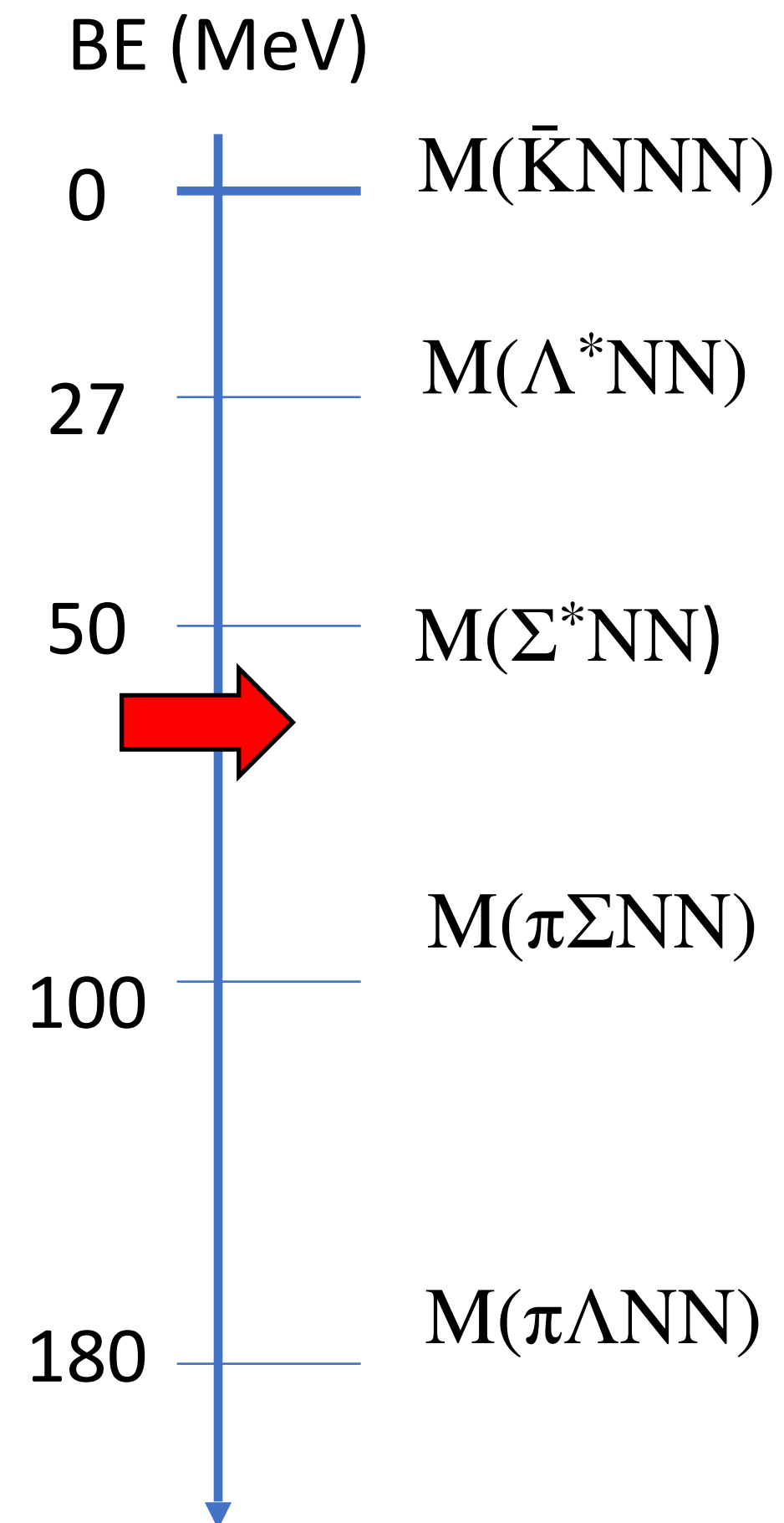

Size of $\bar{K}NNN$ via Data?

One nucleon \bar{K} absorption ($1N_{\bar{K}A}$):

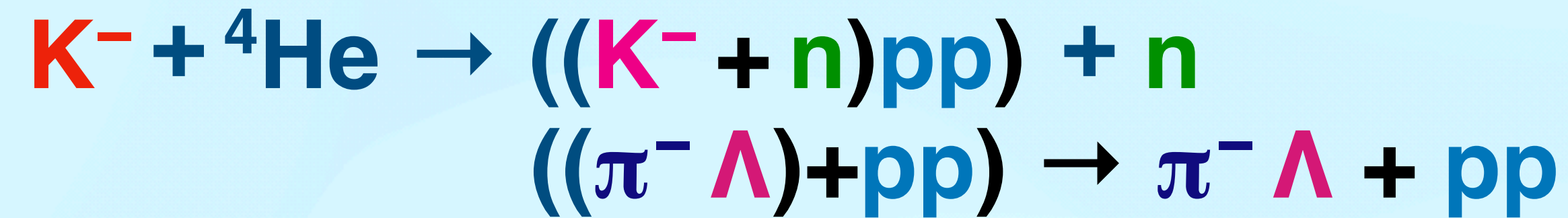

Two nucleon \bar{K} absorption ($2N_{\bar{K}A}$):

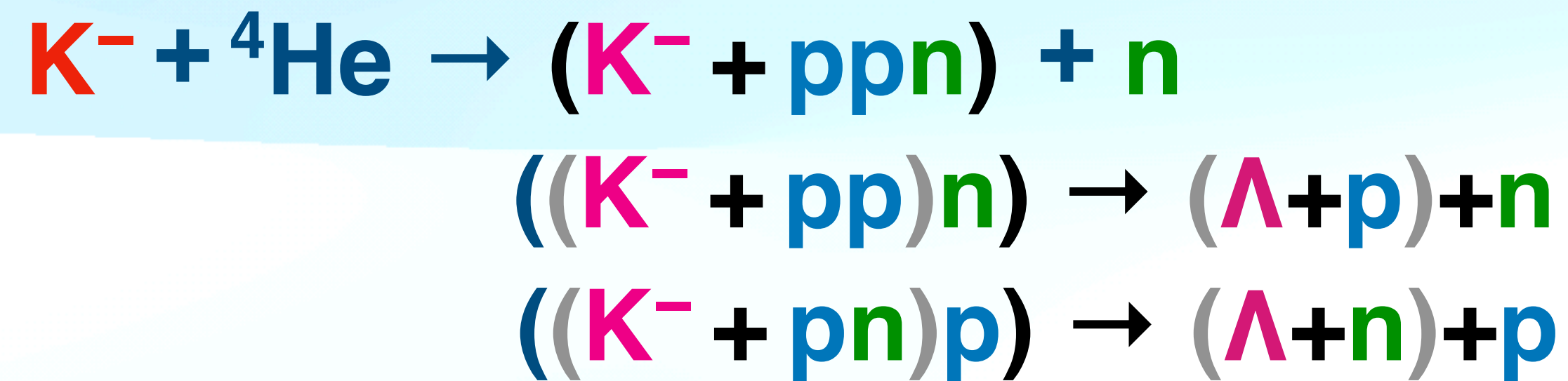

Three nucleon \bar{K} absorption ($3N_{\bar{K}A}$):

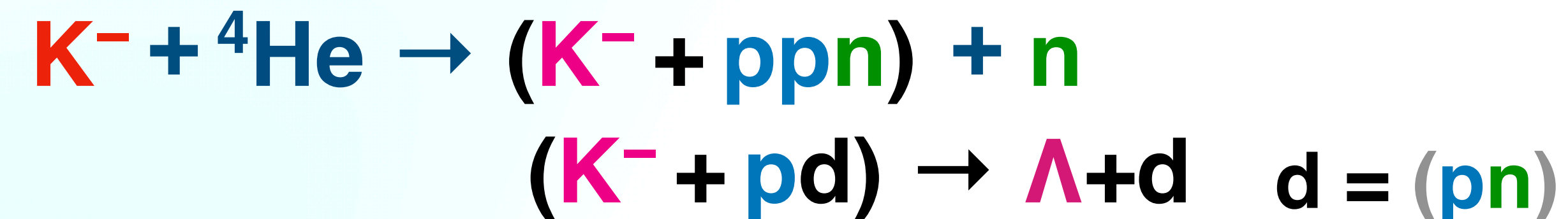

Size of $\bar{K}NNN$ via Data?

One nucleon \bar{K} absorption ($1N_{\bar{K}A}$):

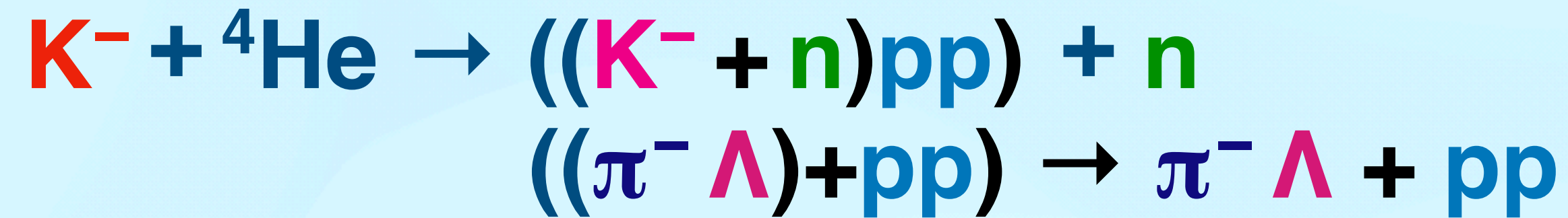

Two nucleon \bar{K} absorption ($2N_{\bar{K}A}$):

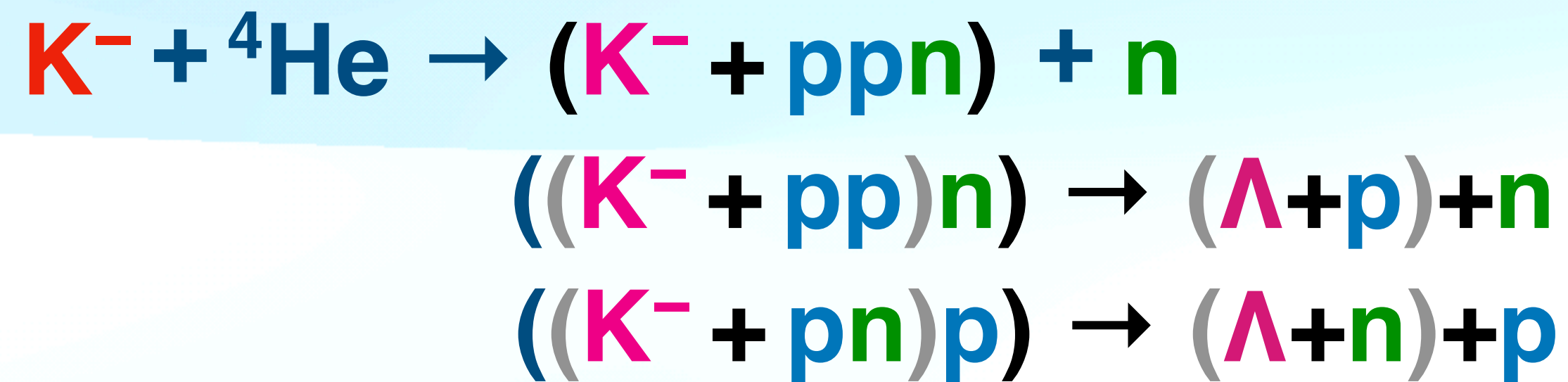

Three nucleon \bar{K} absorption ($3N_{\bar{K}A}$):

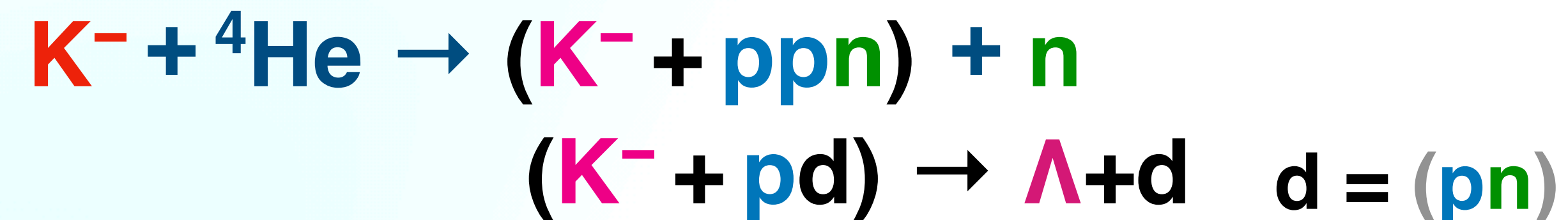

The ratio of the three nucleon processes would be sensitive to the core size.

$$1N_{\bar{K}A} : 2N_{\bar{K}A} : 3N_{\bar{K}A} \sim \rho_N : \rho_N^2 : \rho_N^3 ?$$

Theoretical inputs are needed.

Size of $\bar{K}NNN$ via Data?

One nucleon \bar{K} absorption ($1N_{\bar{K}A}$):

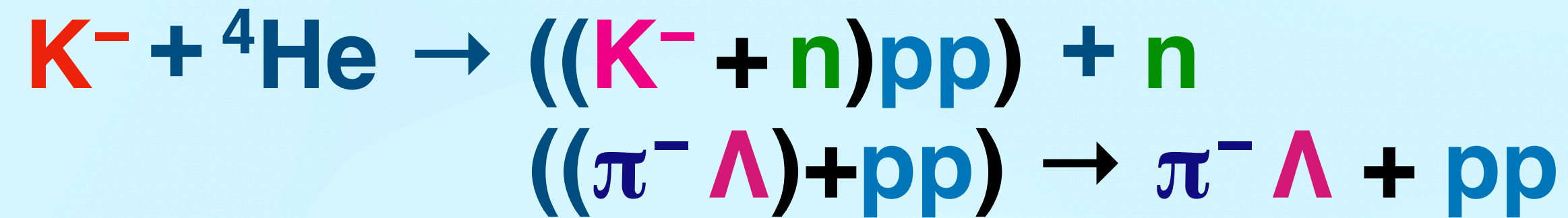

Two nucleon \bar{K} absorption ($2N_{\bar{K}A}$):

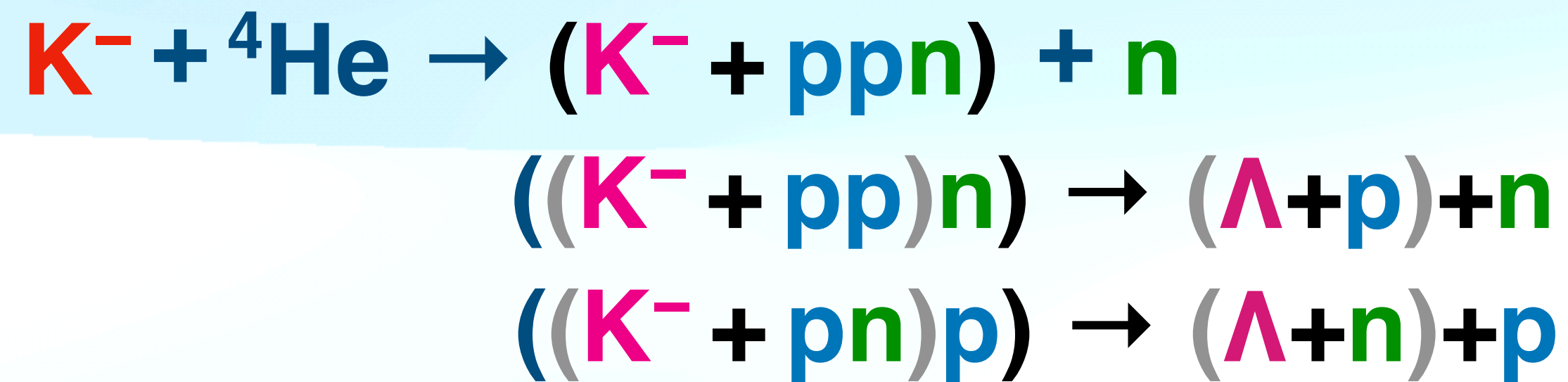

Three nucleon \bar{K} absorption ($3N_{\bar{K}A}$):

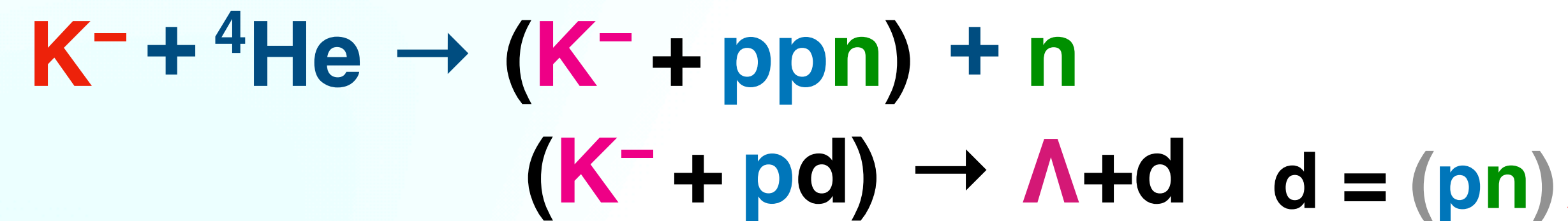

The ratio of the three nucleon processes would be sensitive to the core size.

$$1N_{\bar{K}A} : 2N_{\bar{K}A} : 3N_{\bar{K}A} \sim \rho_N : \rho_N^2 : \rho_N^3 ?$$

Theoretical inputs are needed.

Size of $\bar{K}NNN$ via Data?

One nucleon \bar{K} absorption ($1N_{\bar{K}A}$):

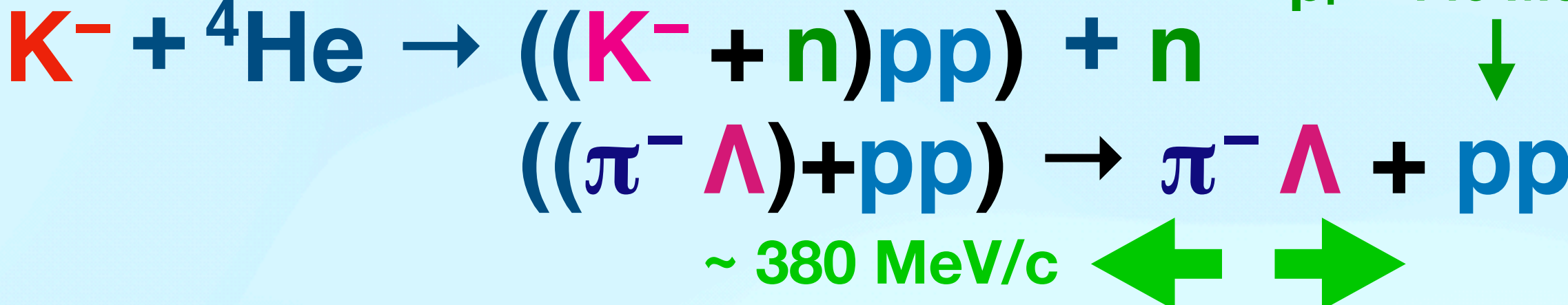

spectators
 $p_F \sim 140 \text{ MeV}/c$
 \downarrow

The ratio of the three nucleon processes would be sensitive to the core size.

$$1N_{\bar{K}A} : 2N_{\bar{K}A} : 3N_{\bar{K}A} \sim \rho_N : \rho_N^2 : \rho_N^3 ?$$

Theoretical inputs are needed.

Two nucleon \bar{K} absorption ($2N_{\bar{K}A}$):

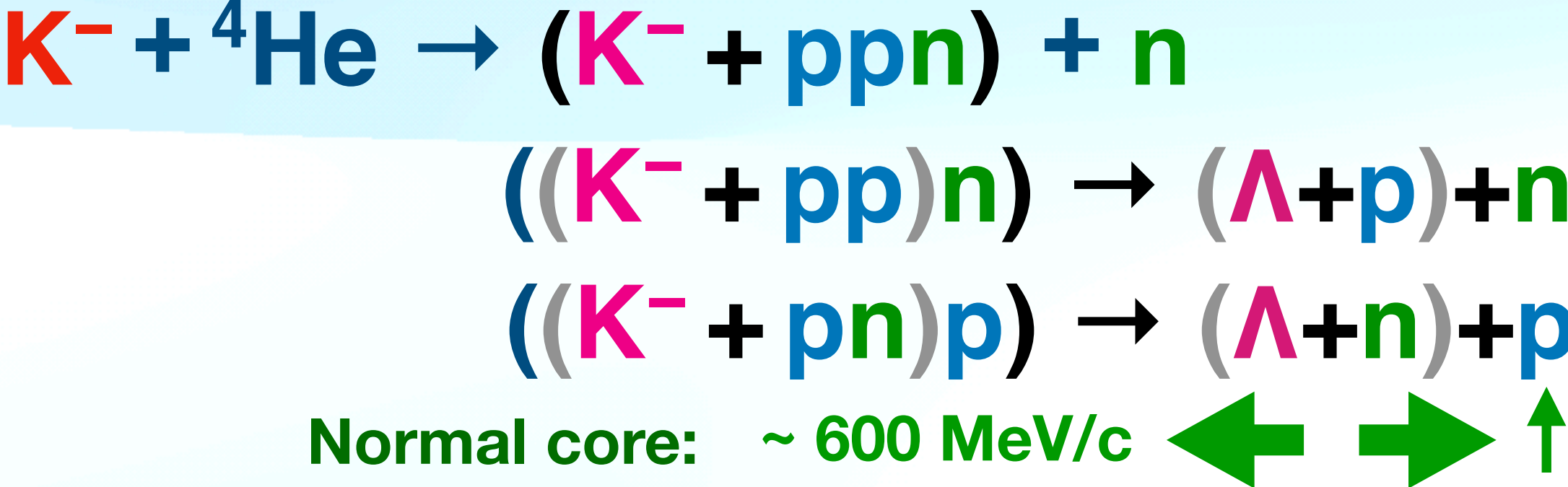

spectators
 $p_F \sim 140 \text{ MeV}/c$

Three nucleon \bar{K} absorption ($3N_{\bar{K}A}$):

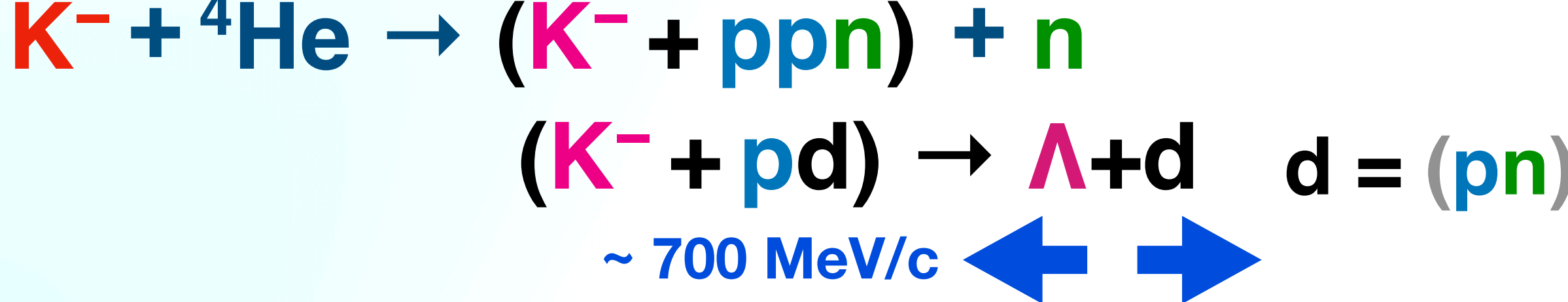

Dalitz plots

Normal core:

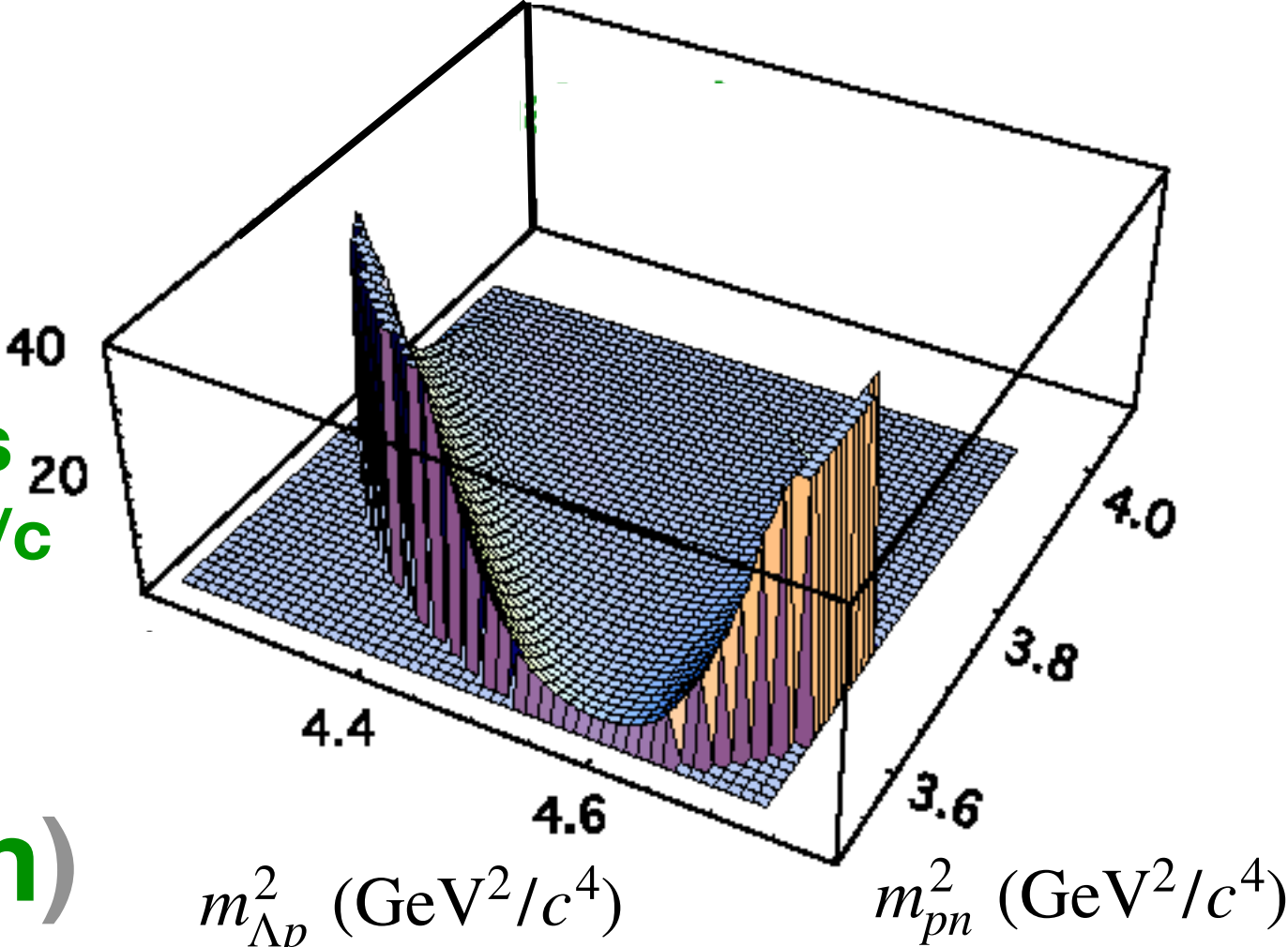

Size of $\bar{K}NNN$ via Data?

One nucleon \bar{K} absorption ($1N_{\bar{K}A}$):

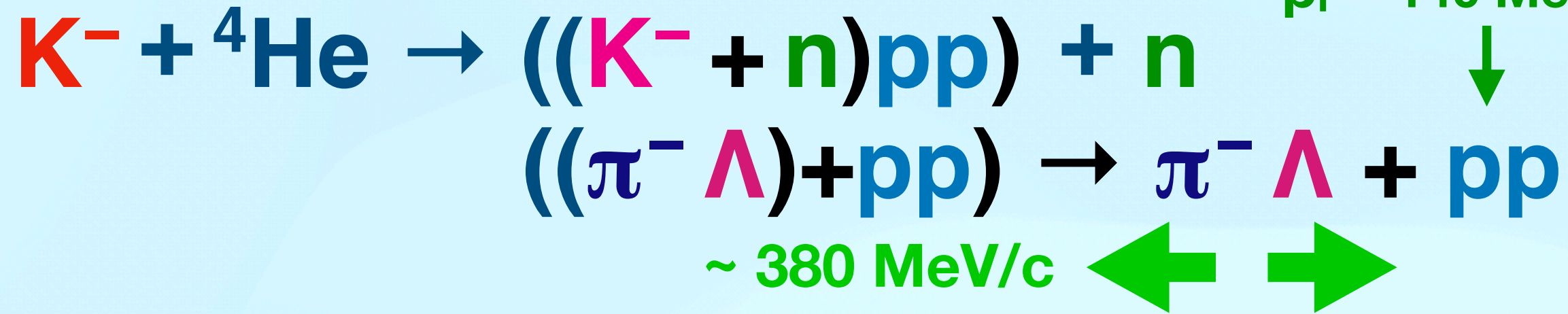

The ratio of the three nucleon processes would be sensitive to the core size.

$$1N_{\bar{K}A} : 2N_{\bar{K}A} : 3N_{\bar{K}A} \sim \rho_N : \rho_N^2 : \rho_N^3 ?$$

Theoretical inputs are needed.

Two nucleon \bar{K} absorption ($2N_{\bar{K}A}$):

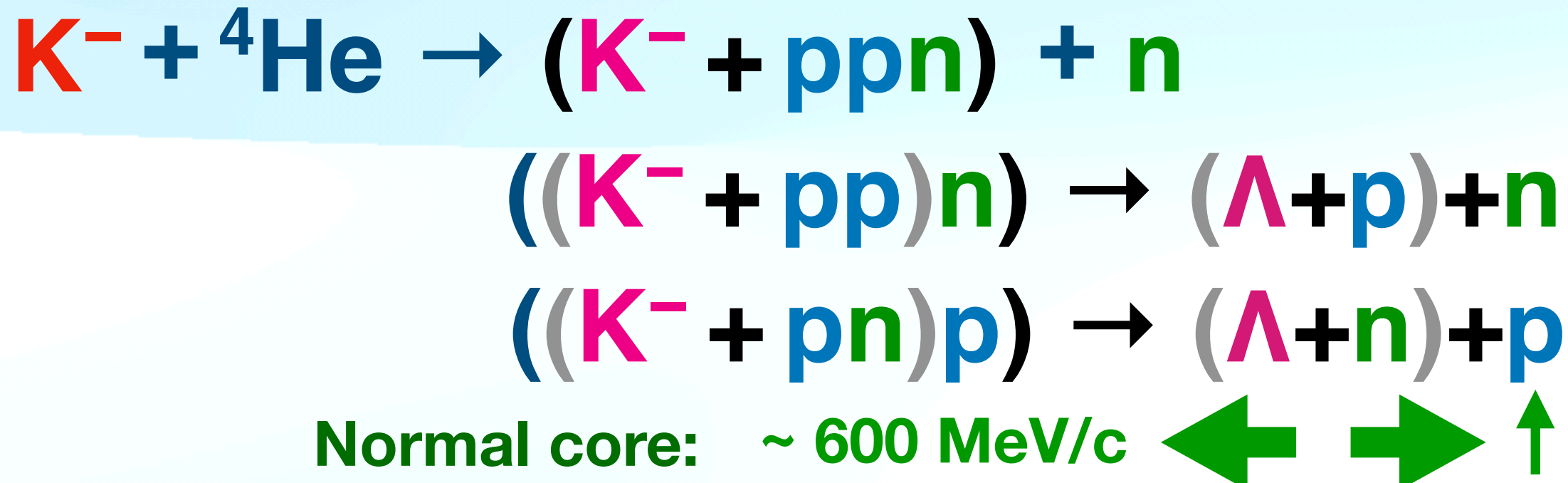

Dalitz plots

Three nucleon \bar{K} absorption ($3N_{\bar{K}A}$):

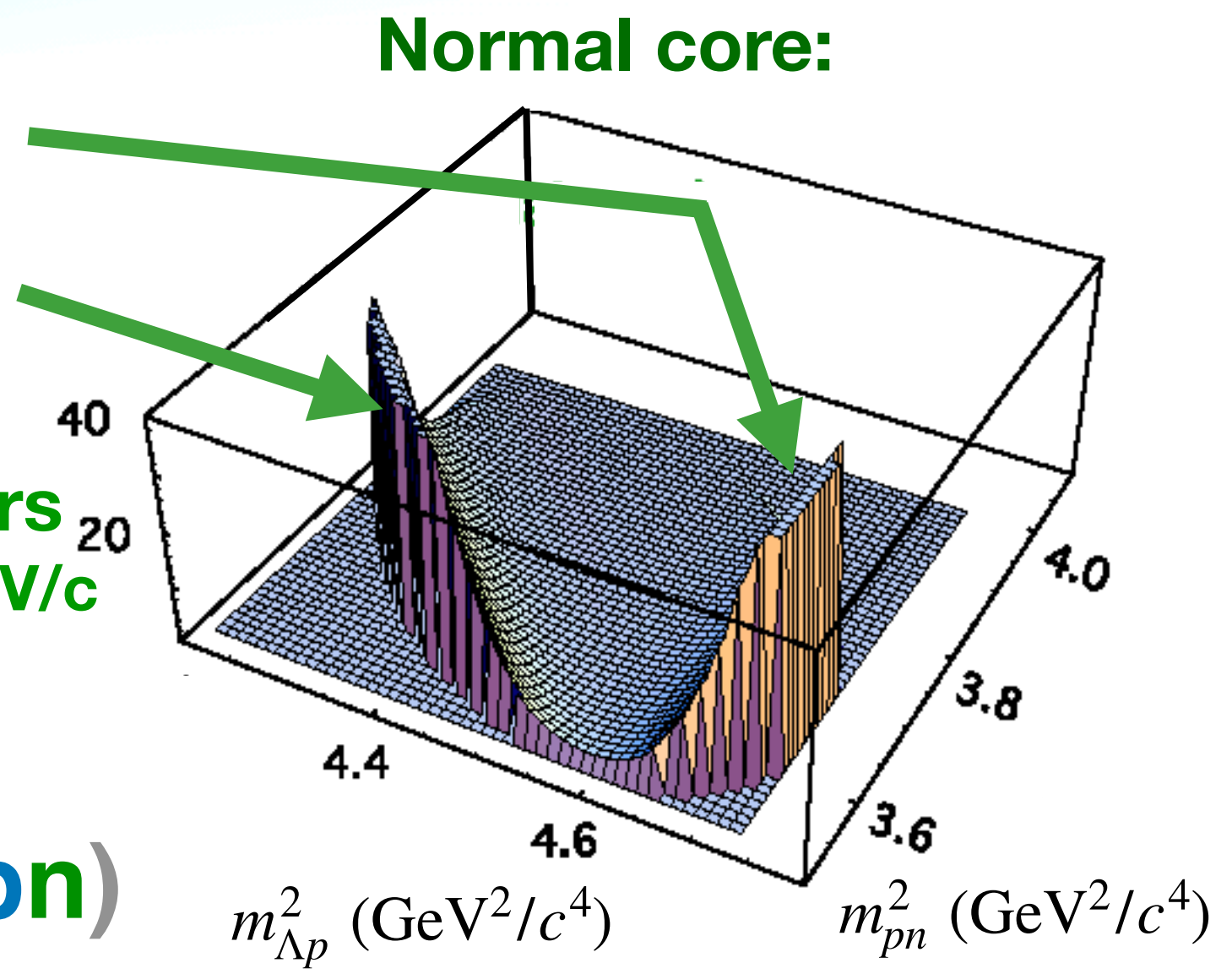
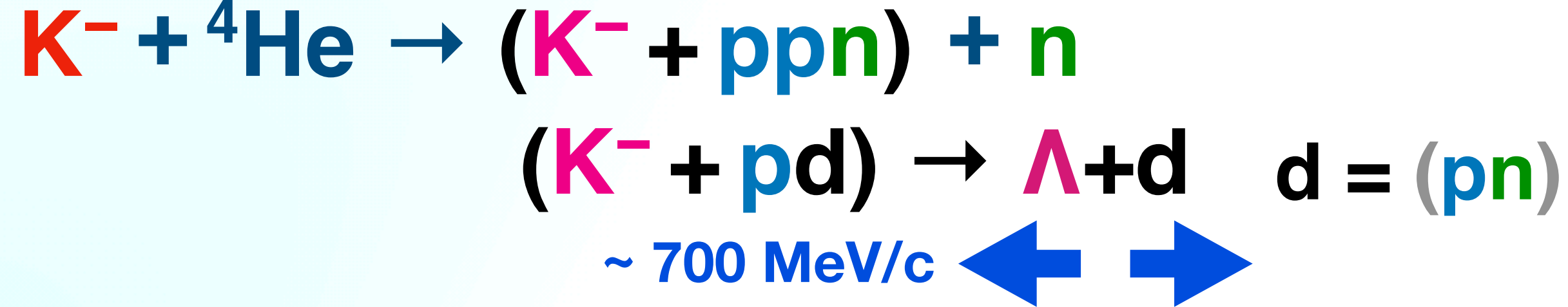

Size of $\bar{K}NNN$ via Data?

One nucleon \bar{K} absorption ($1N_{\bar{K}A}$):

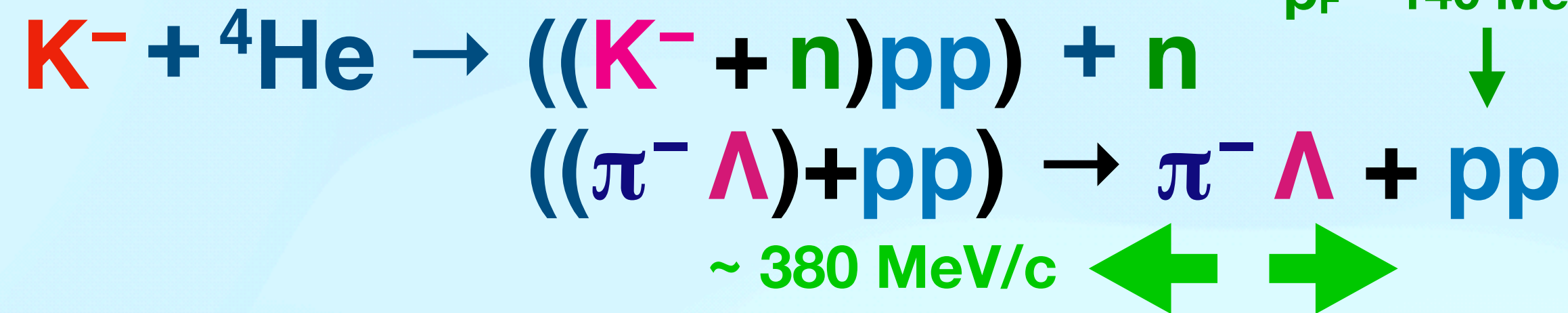

The ratio of the three nucleon processes would be sensitive to the core size.

$$1N_{\bar{K}A} : 2N_{\bar{K}A} : 3N_{\bar{K}A} \sim \rho_N : \rho_N^2 : \rho_N^3 ?$$

Theoretical inputs are needed.

Two nucleon \bar{K} absorption ($2N_{\bar{K}A}$):

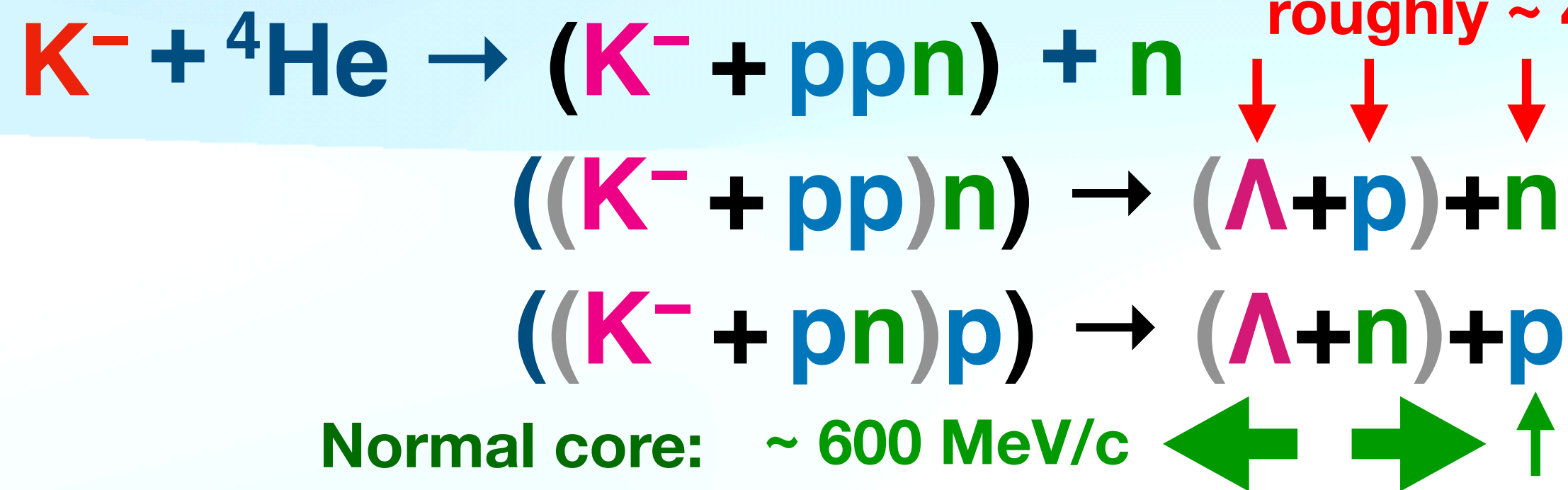

Dalitz plots

Compact core:

Three nucleon \bar{K} absorption ($3N_{\bar{K}A}$):

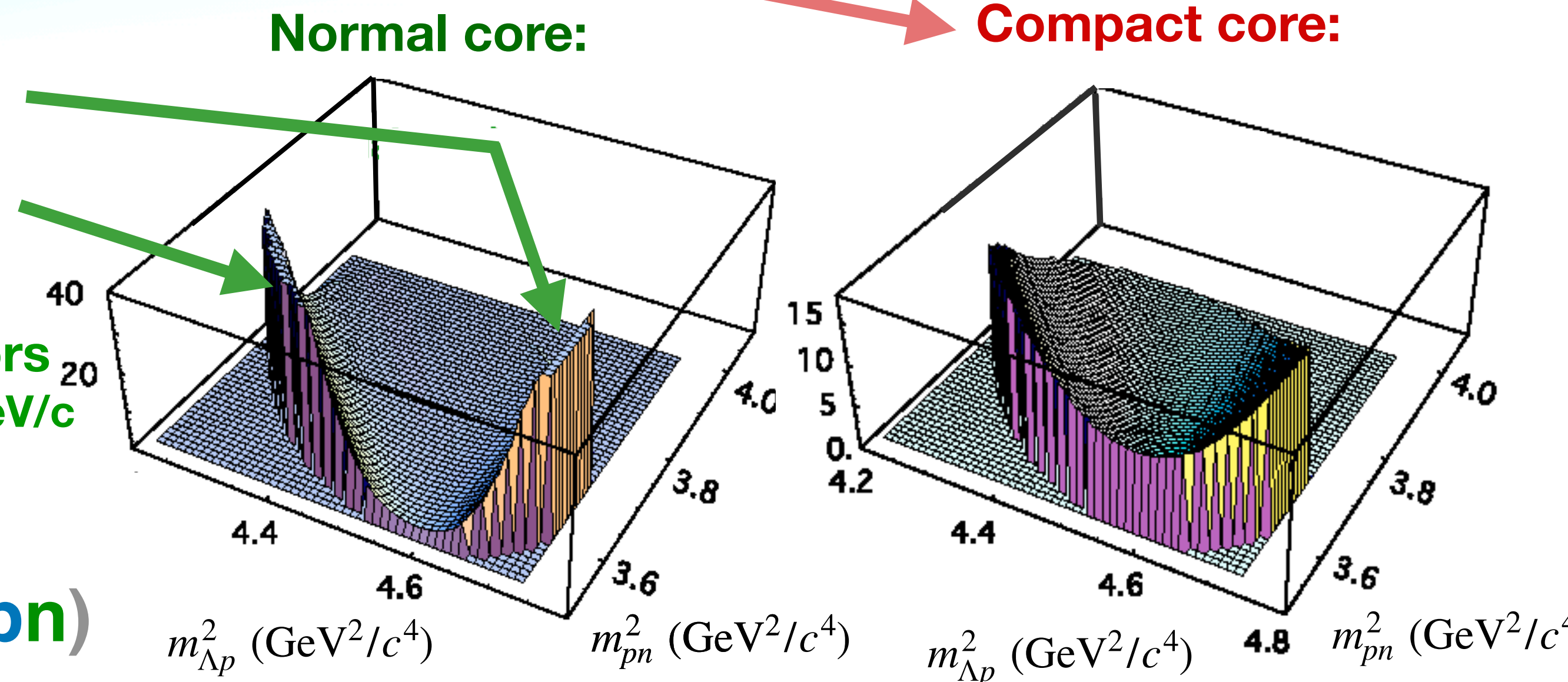
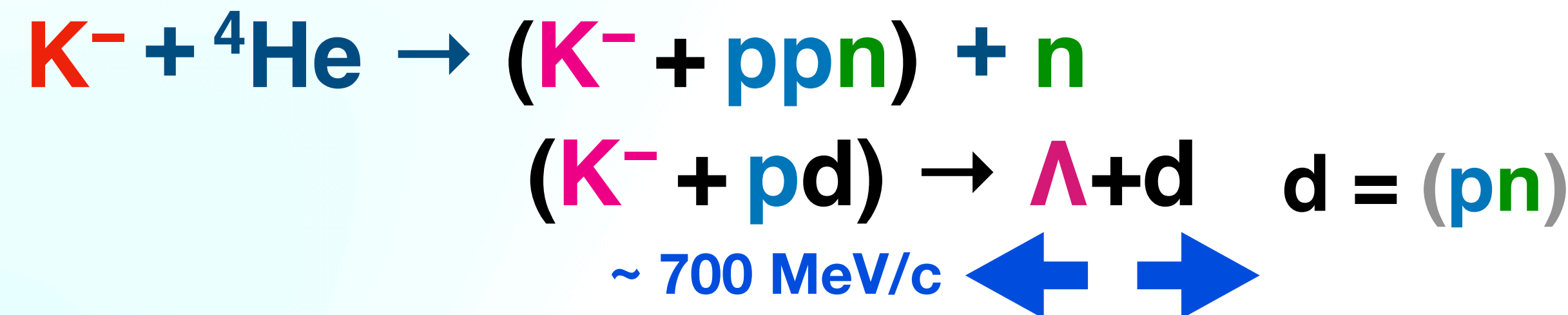

Toward next generation research — New Spectrometer —

Does Isospin-partner $(\bar{K}^0 nn)_{I_3 = -1/2}$ exist?

Are kaonic nuclei really compact?

Theoretical exploration of Kaonic Nuclei.

for the systematic study on

$(\sim 10^{-15} \text{ m})$



molecule-like hadronic nuclear cluster⁰

"Does it have a unique shape like a chemical molecule?"

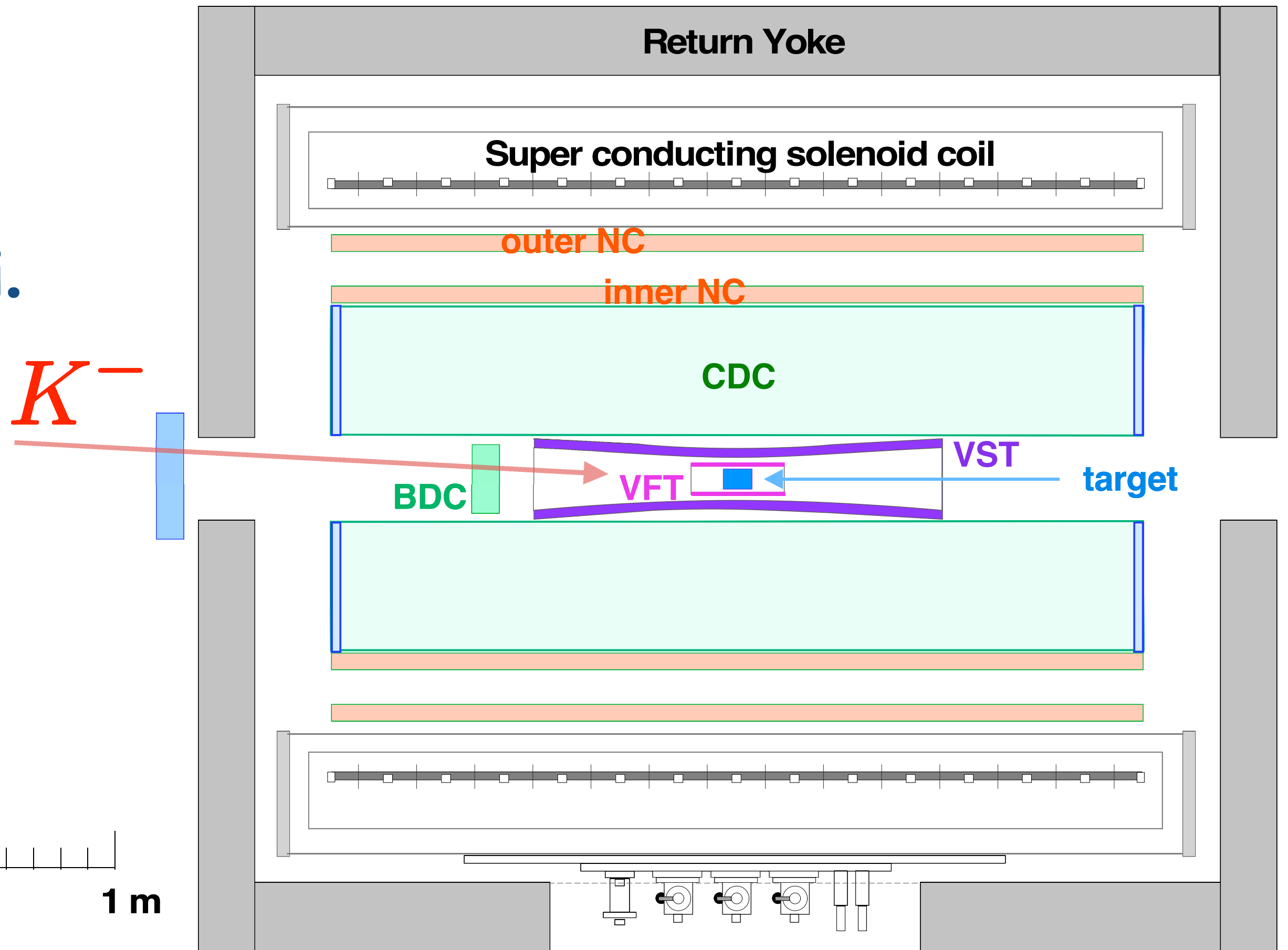
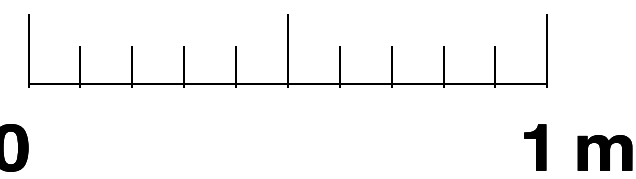

... Construction is in progress, led by *F. Sakuma* 25

Toward next generation research — New Spectrometer —

Does Isospin-partner $(\bar{K}^0 nn)_{I_3 = -1/2}$ exist?

Are kaonic nuclei really compact?

Theoretical exploration of Kaonic Nuclei.

for the systematic study on

($\sim 10^{-15}$ m)

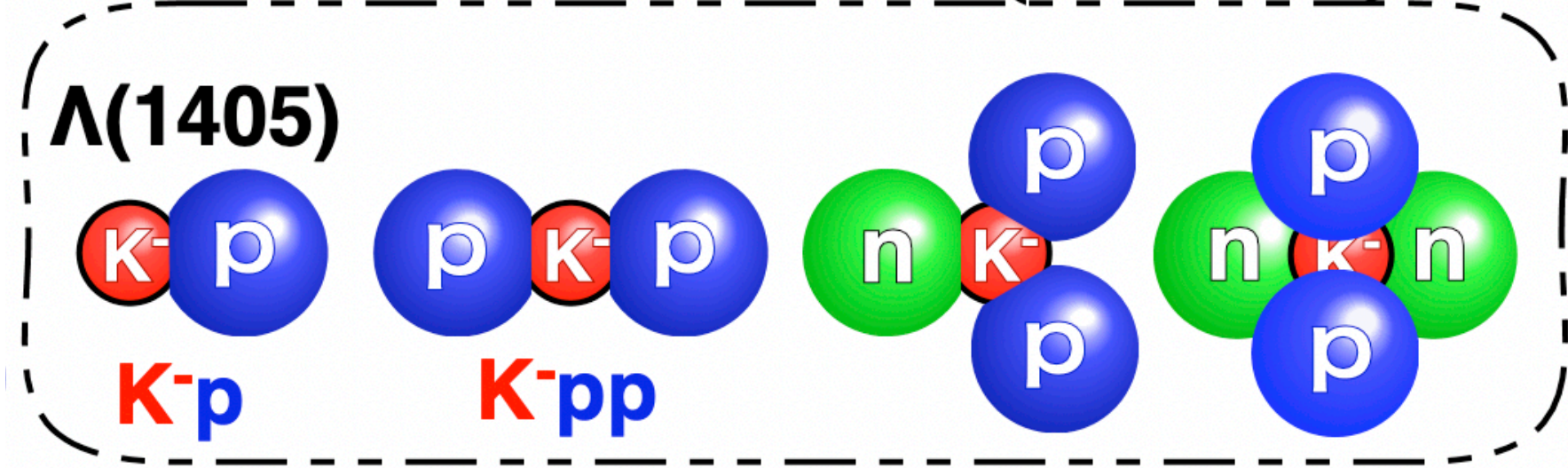

molecule-like hadronic nuclear cluster⁰

"Does it have a unique shape like a chemical molecule?"

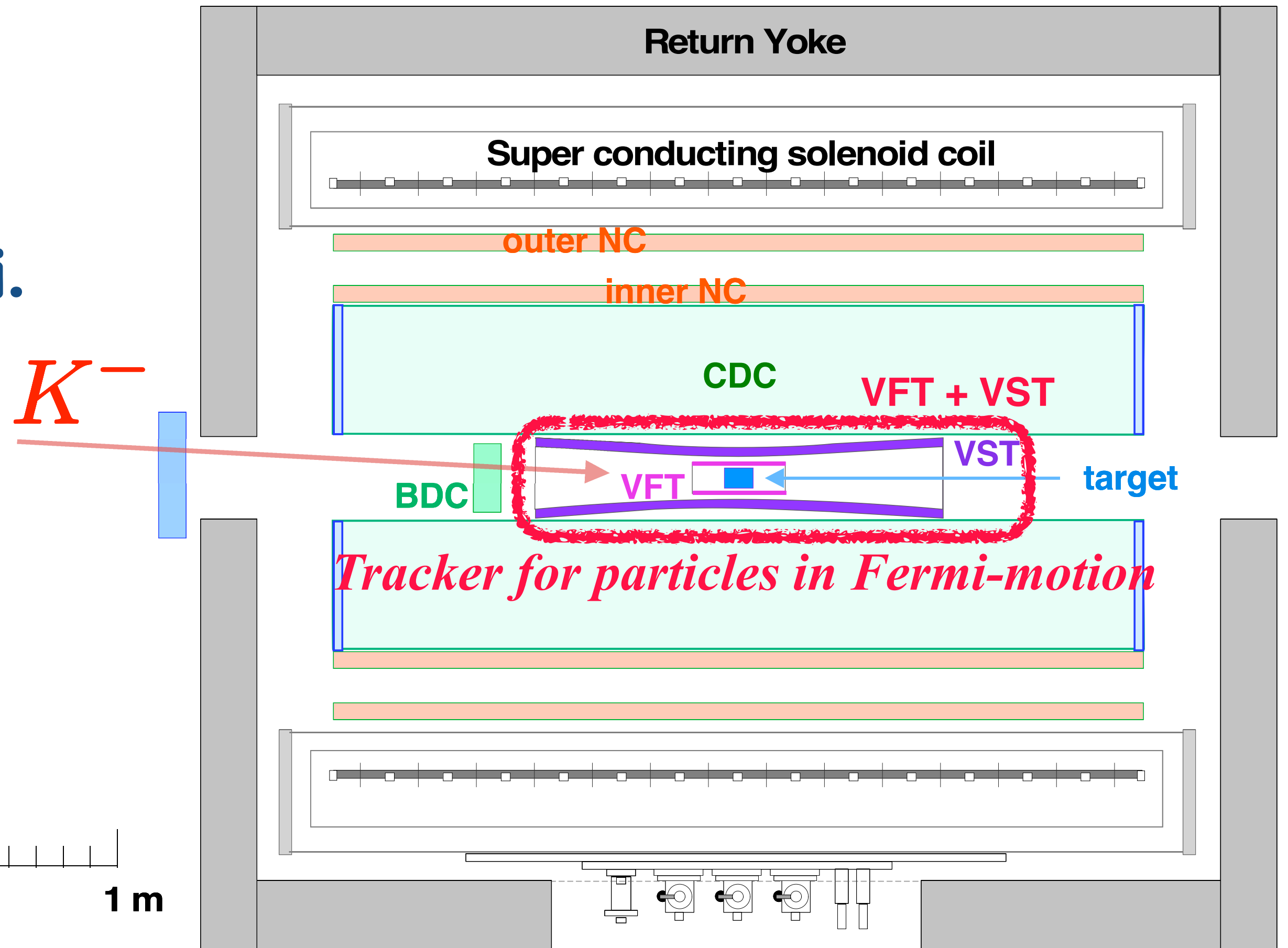

... Construction is in progress, led by *F. Sakuma* 25

New Cylindrical Detector System (CDS)

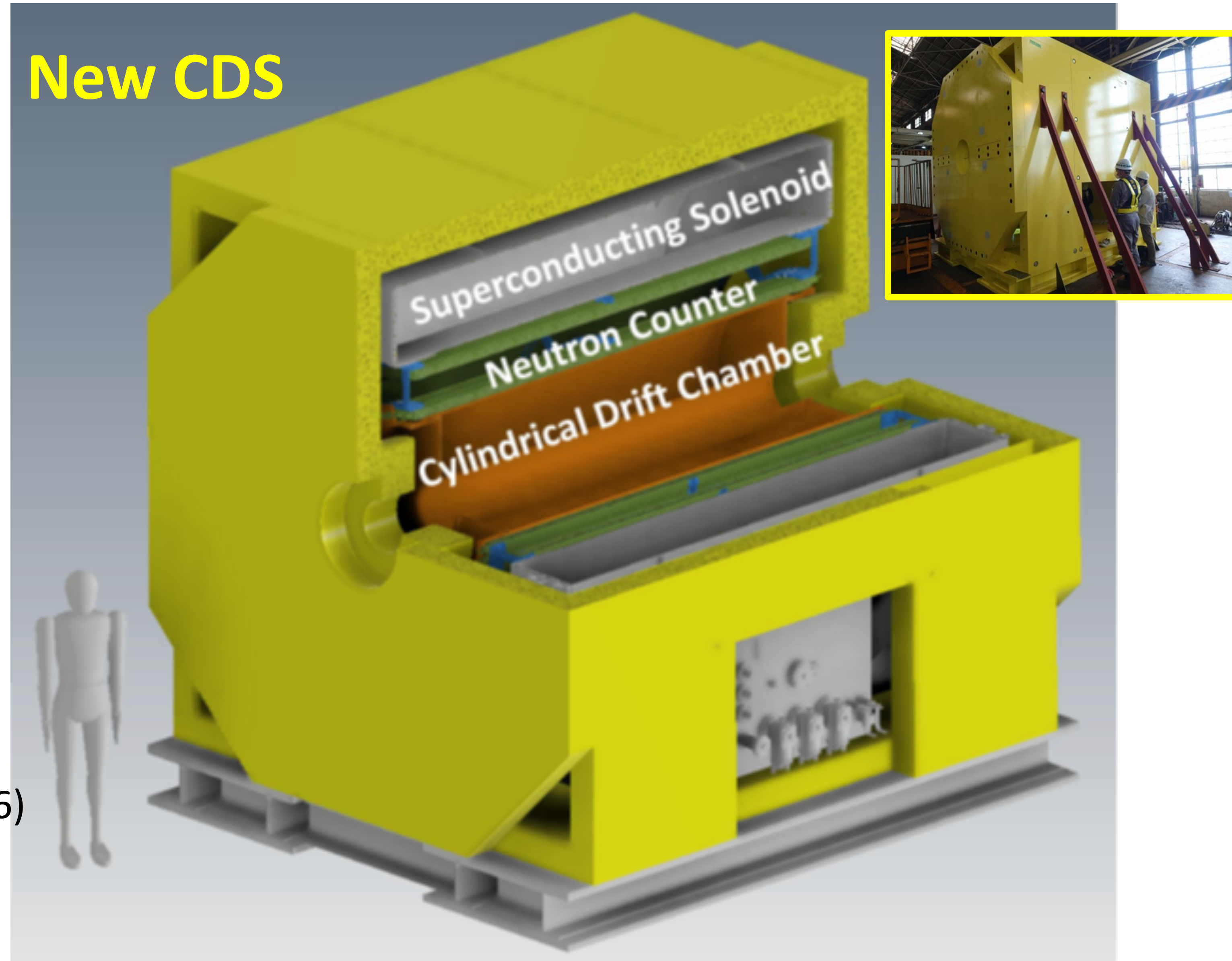
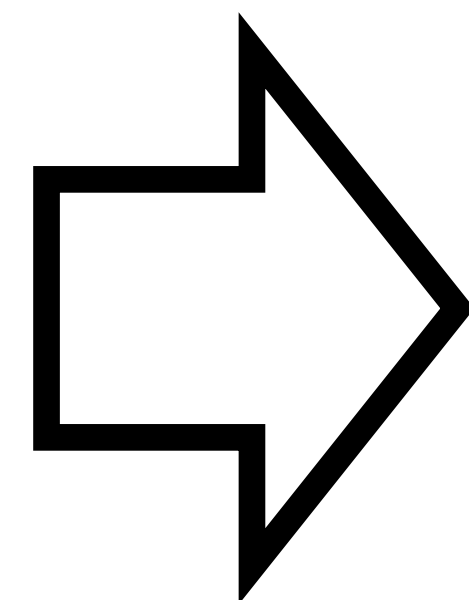
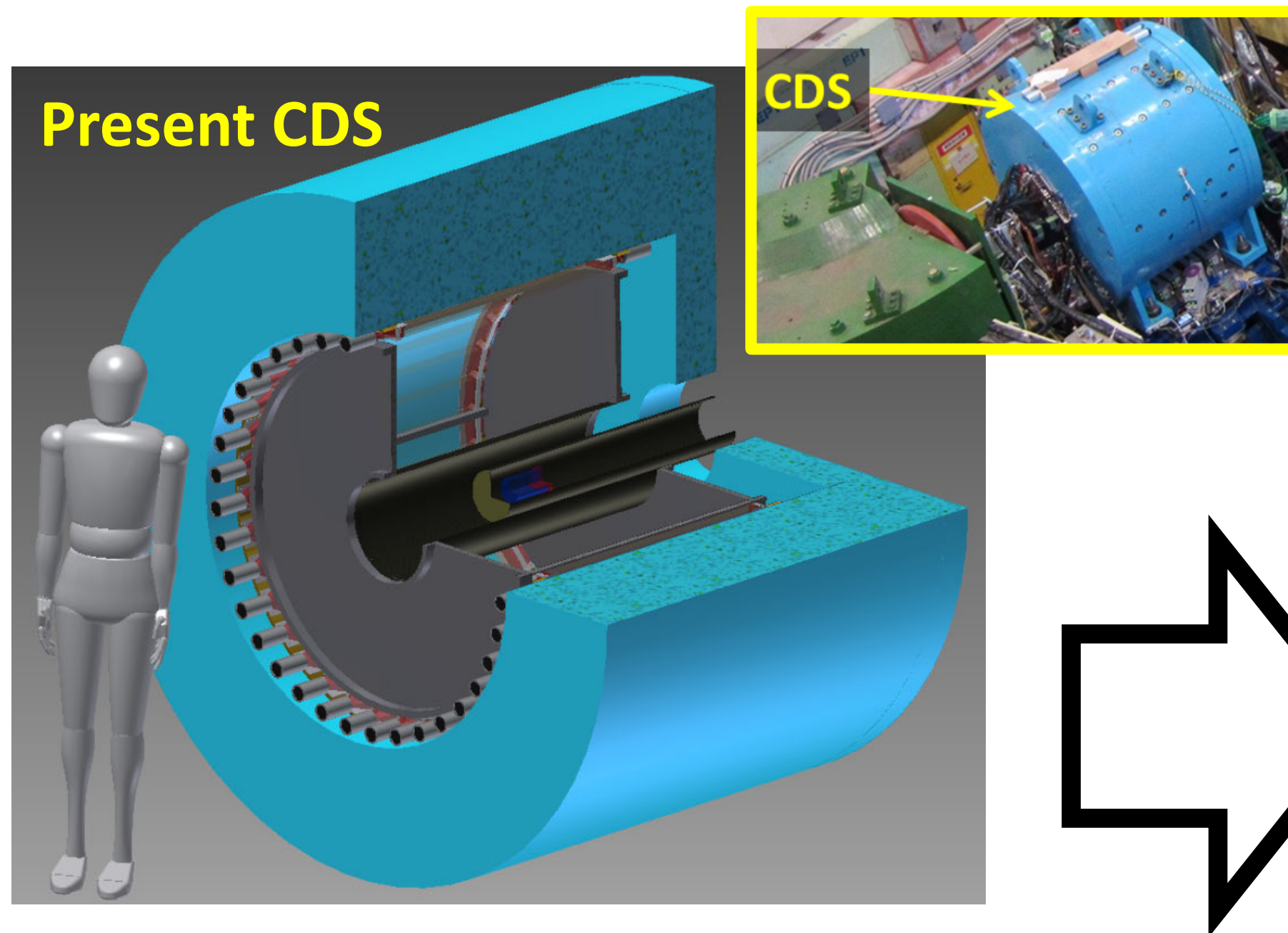

- ✓ **Solid angle:** **x1.6** (59% → 93%)
- ✓ **Neutron eff.:** **x7** (3% → 12%x1.6)

With new spectrometer, we will conduct

— a systematic study on light kaonic nuclei —

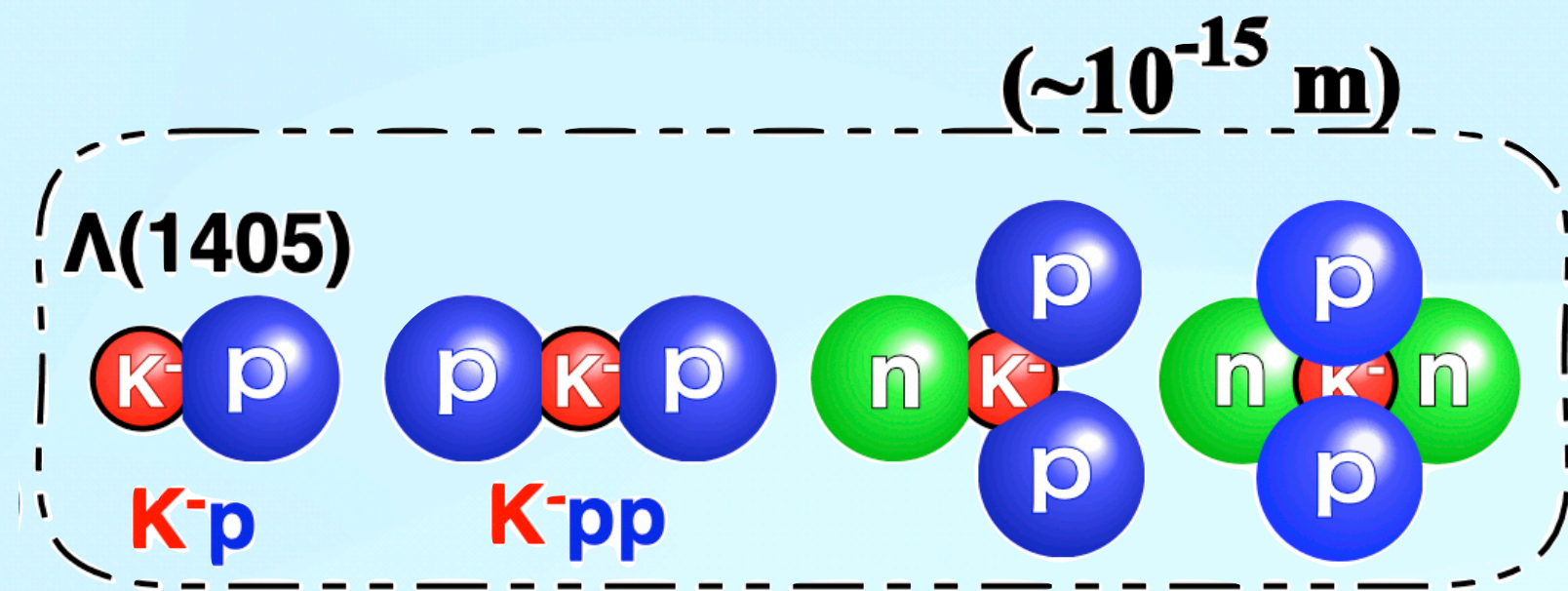

"Does it have a unique shape like a chemical molecule?"

molecule-like hadronic nuclear cluster

By establishing *the $I(J^P)$* , presence of " $K^- nn$ " — a Charge Mirror State of " $K^- pp$ " — and *the Detailed Study of Three-Nucleon Kaon Nuclear Bound State as new starting points, we aim to open the door to research on high-density nuclear matter.*

How hadron mass is generated?

Physics at high density?

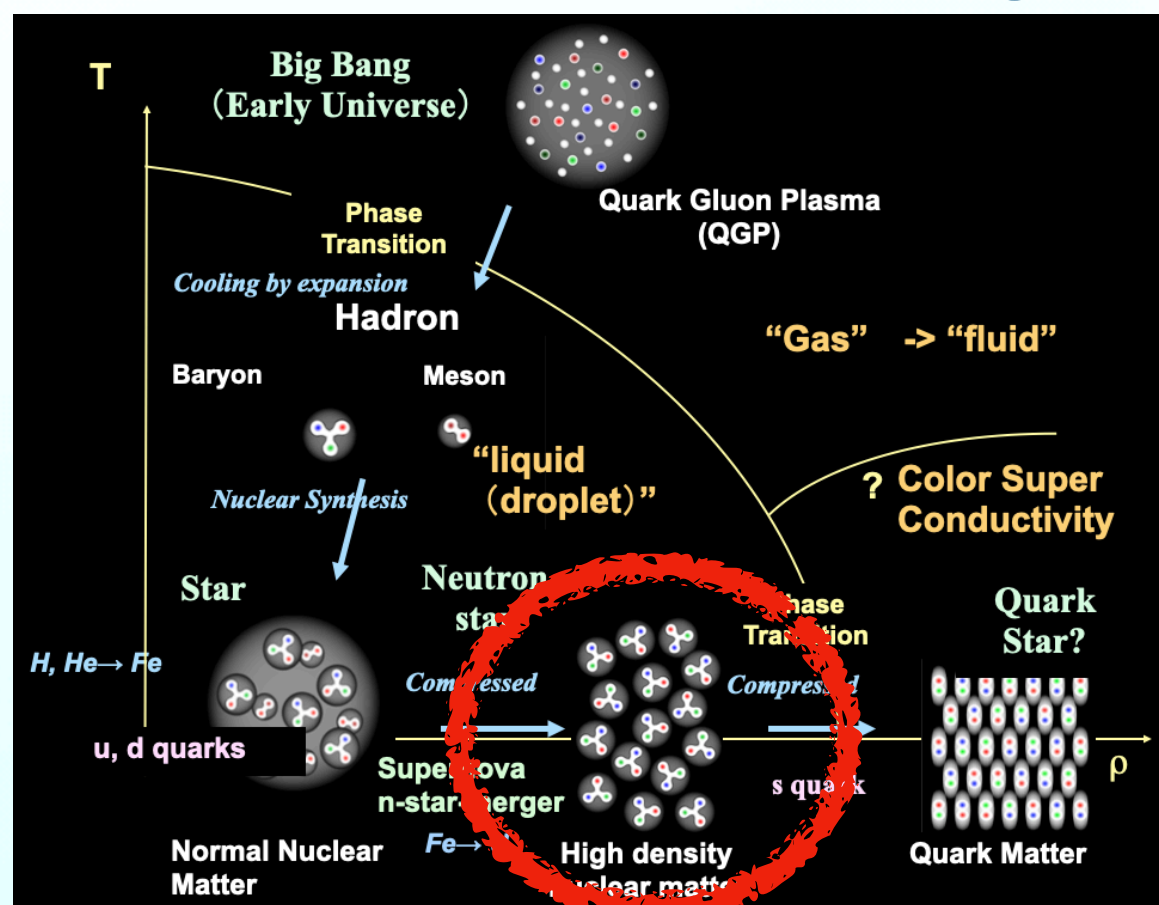

Thank you for your attention!

Acceptance for $K^-4\text{He}$ reaction

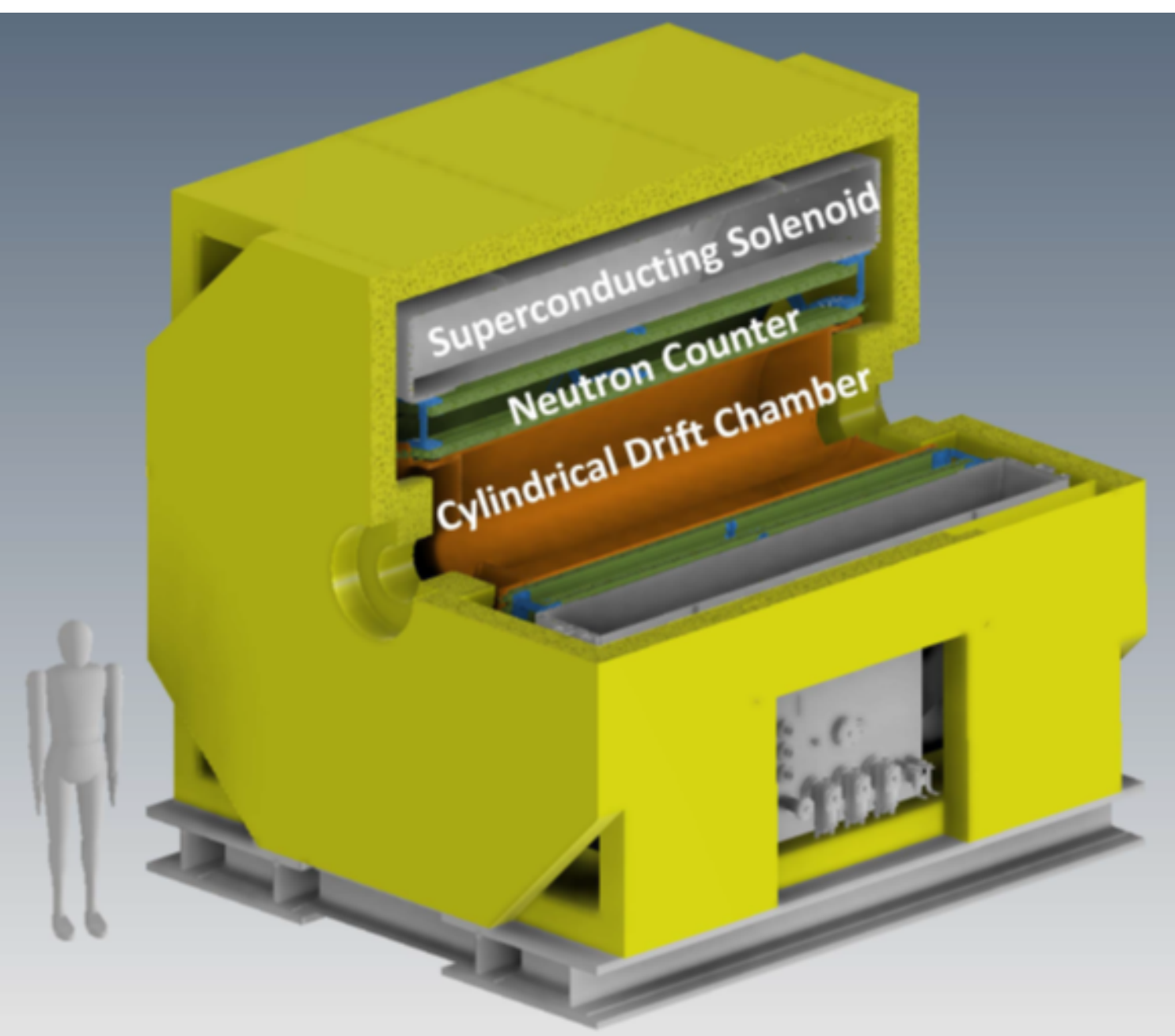
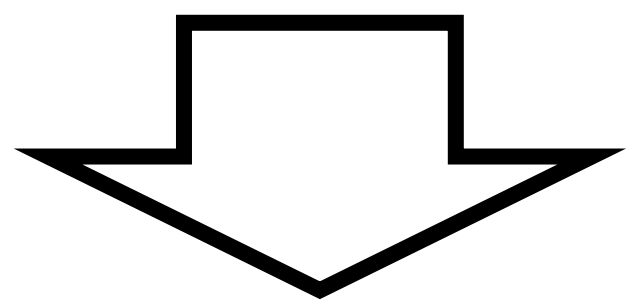
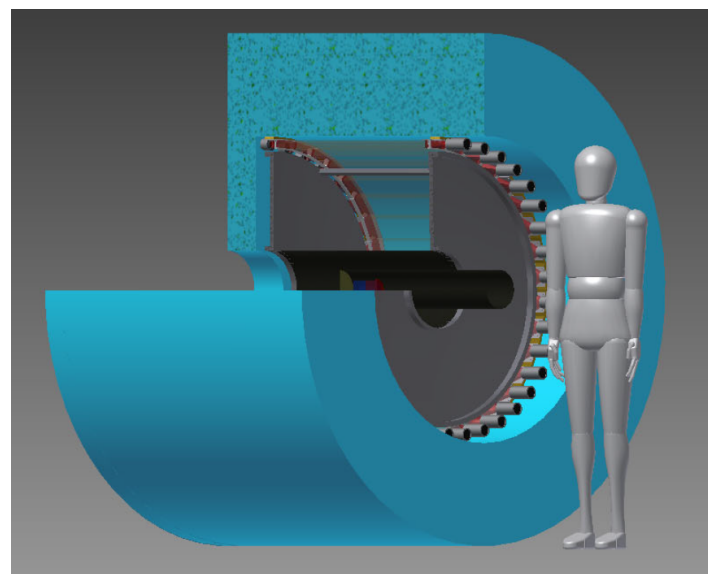

Δd in CDS

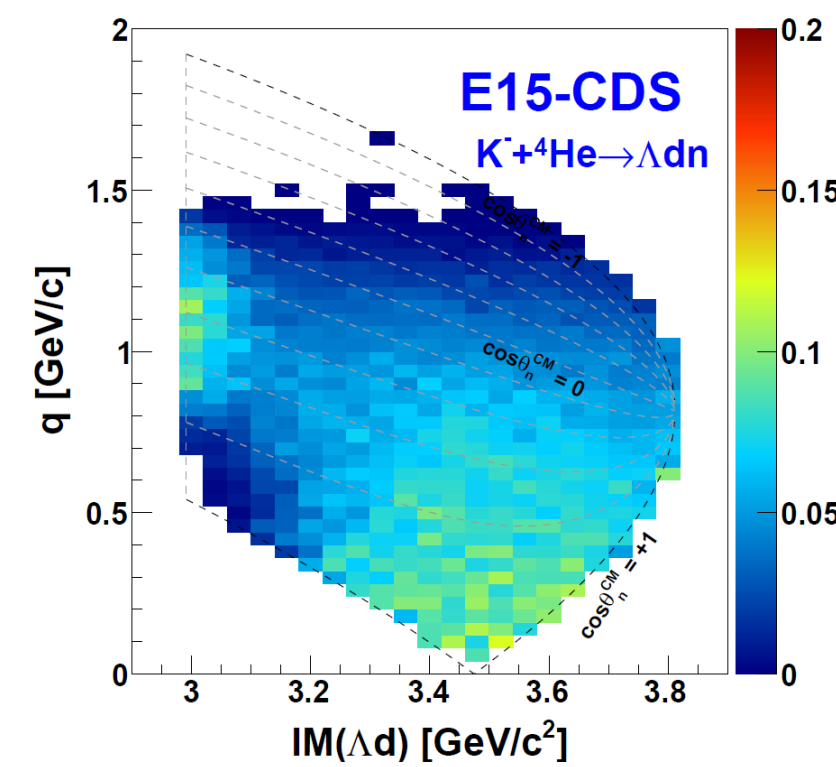

Δpn in CDS

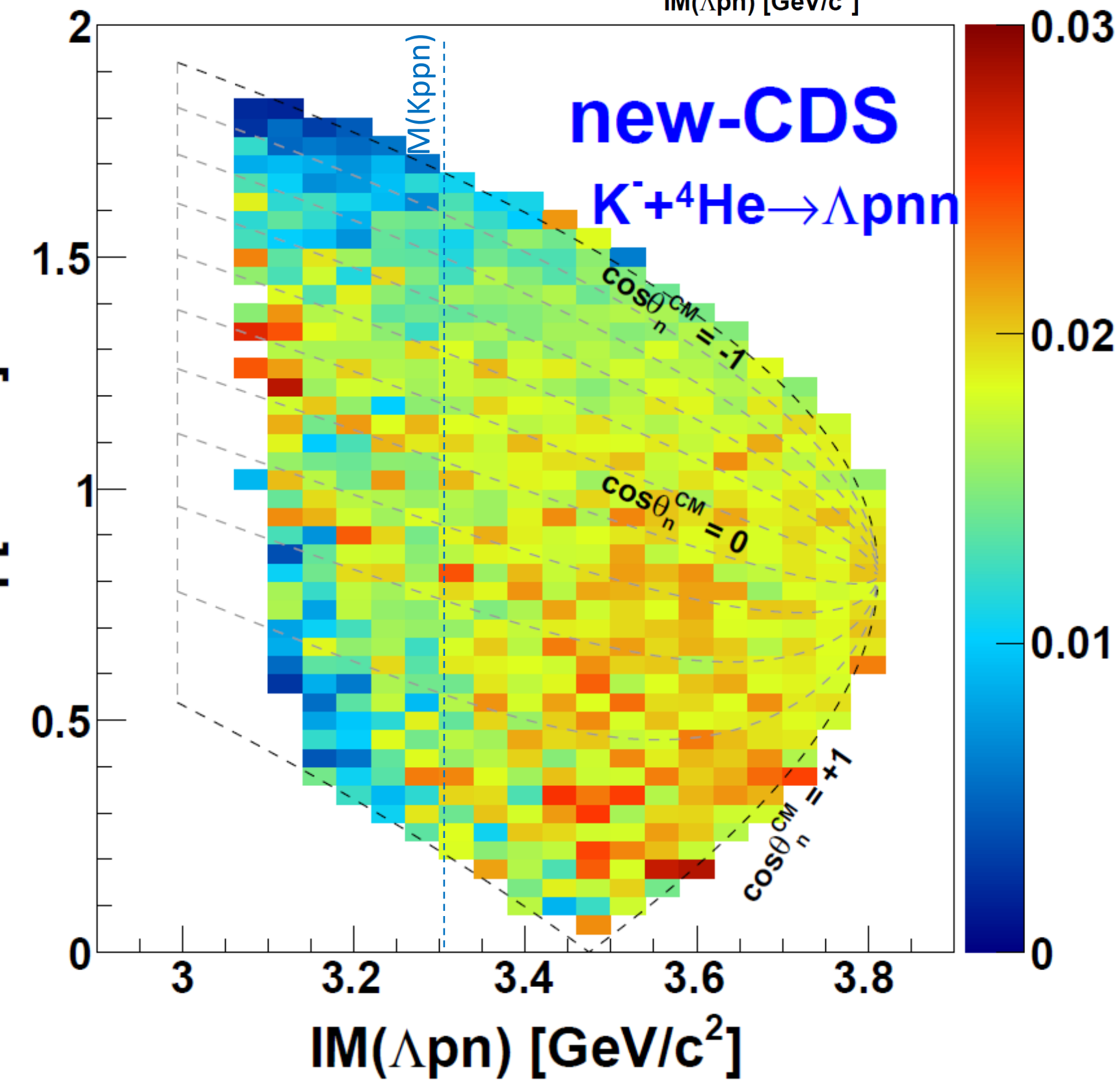
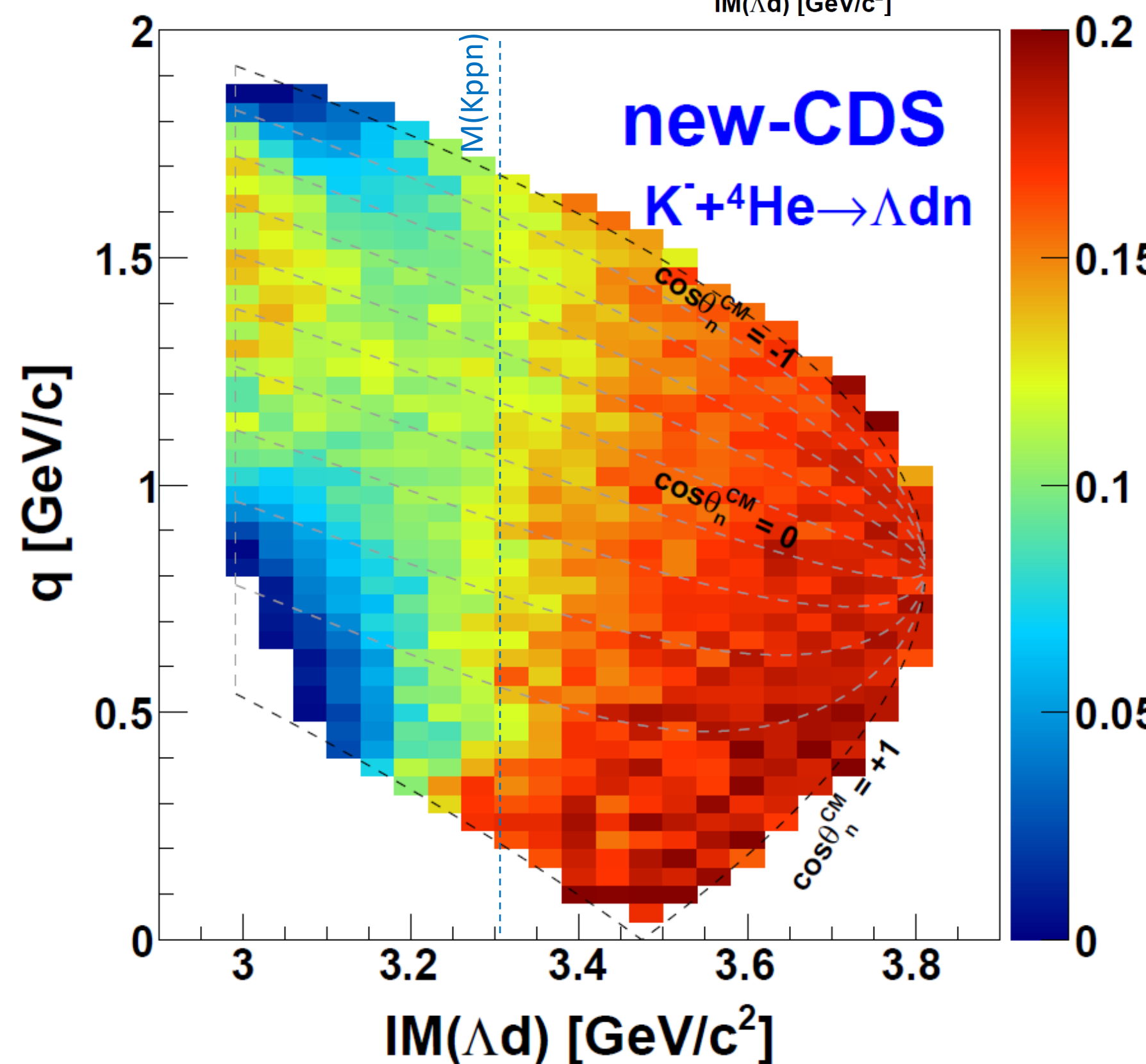
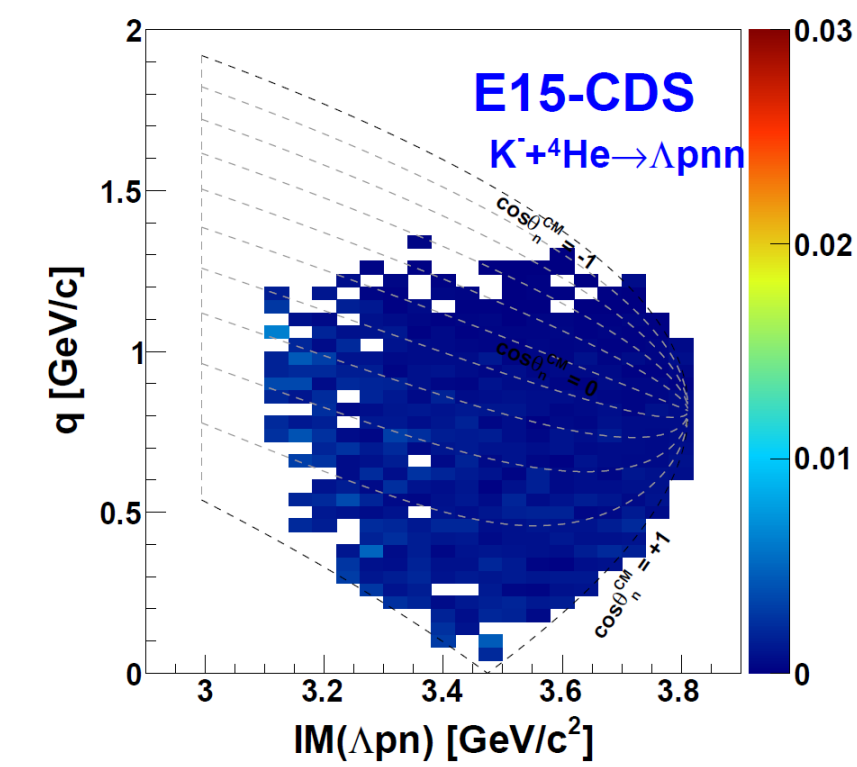

Possible $I(J^P)$?

$\bar{K}NN : J^P = 0^-, I = 1/2: I_{NN} = 1, S_{NN} = 0, L_{\bar{K}} = 0$

nucleon isospin symmetric ($I_{NN} = 1$) and spin anti-symmetric ($S_{NN} = 0$)

$\bar{K}NN : J^P = 1^-, I = 1/2: I_{NN} = 0, S_{NN} = 1, L_{\bar{K}} = 0$

nucleon isospin anti-symmetric ($I_{NN} = 0$) and spin symmetric ($S_{NN} = 1$)

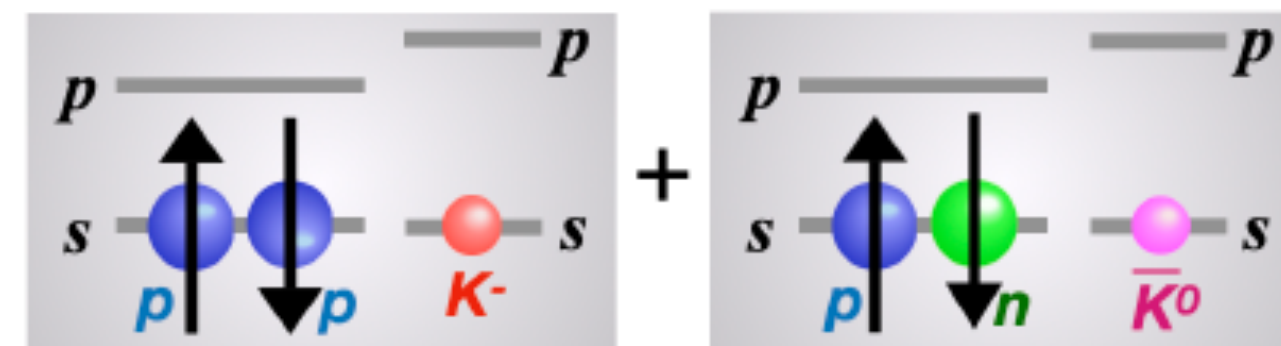
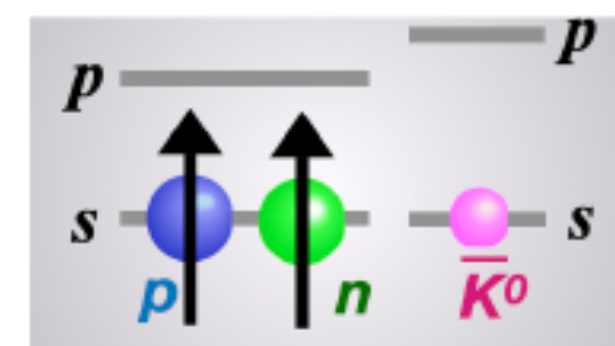
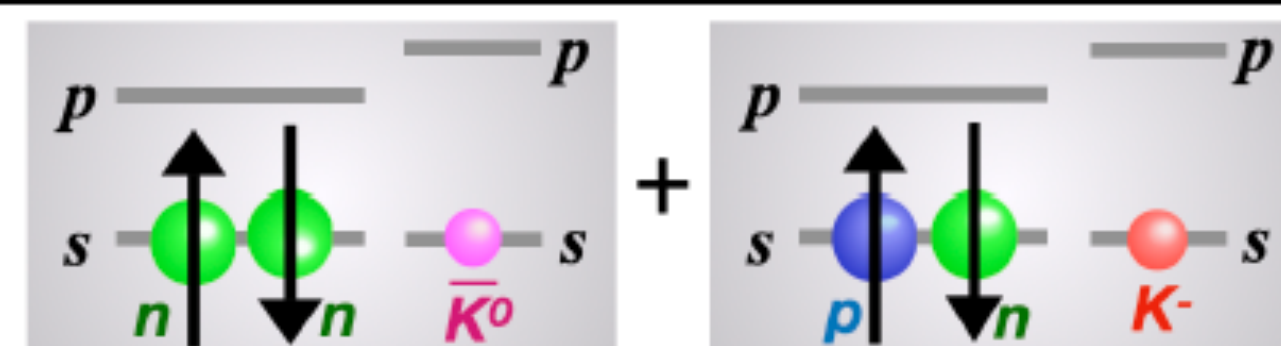
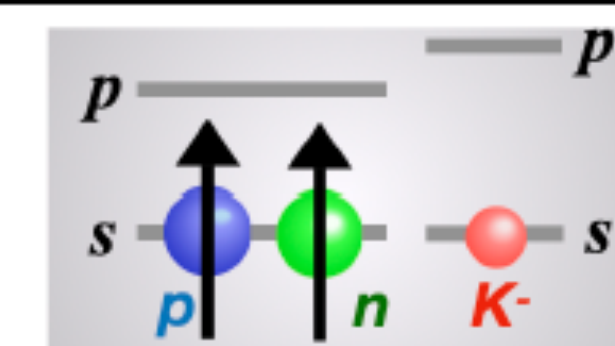
$I(\bar{K}NN) / J^P(\bar{K}NN)$	$(1/2) / (0^-)$	$(1/2) / (1^-)$
<i>NN symmetry</i>	$I(NN) = 1, S(NN) = 0$	$I(NN) = 0, S(NN) = 1$
<p>“$K^- pp$”</p> <p>$I_3(\bar{K}NN) = +\frac{1}{2}$</p>  $-\sqrt{\frac{1}{3}} \left(\sqrt{2} K^- pp + \bar{K}^0 \frac{pn + np}{\sqrt{2}} \right) \otimes \left(\frac{\uparrow\downarrow - \downarrow\uparrow}{\sqrt{2}} \right)$	 $\bar{K}^0 \frac{(pn - np)}{\sqrt{2}} \otimes \left(\uparrow\uparrow, \frac{\uparrow\downarrow + \downarrow\uparrow}{\sqrt{2}}, \downarrow\downarrow \right)$	
<p>“$\bar{K}^0 nn$”</p> <p>$I_3(\bar{K}NN) = -\frac{1}{2}$</p>  $-\sqrt{\frac{1}{3}} \left(\sqrt{2} \bar{K}^0 nn + K^- \frac{pn + np}{\sqrt{2}} \right) \otimes \left(\frac{\uparrow\downarrow - \downarrow\uparrow}{\sqrt{2}} \right)$	 $-K^- \frac{(pn - np)}{\sqrt{2}} \otimes \left(\uparrow\uparrow, \frac{\uparrow\downarrow + \downarrow\uparrow}{\sqrt{2}}, \downarrow\downarrow \right)$	
<i>$\bar{K}N$ coupling</i>	$\frac{ I_{\bar{K}N} = 0 ^2}{ I_{\bar{K}N} = 1 ^2} = \frac{3}{1}$	$\frac{ I_{\bar{K}N} = 0 ^2}{ I_{\bar{K}N} = 1 ^2} = \frac{1}{3}$
$\frac{\sigma_{\bar{K}^0 nn}}{\sigma_{K^- pp}}$	$0.13 \sim 0.15$	~ 0.75

“ $K^- pp$ ” $\rightarrow \Lambda p$ requires $I = 1/2$, presence of kaon requires negative parity, and the Λp decay must be in P-wave due to the negative parity

Λp decay axis and spin axis of $\bar{K}NN$ J^P

spin axis distribution referring to the decay axis

$\bar{K}NN : J^P = 0^-, I = 1/2: I_{NN} = 1, S_{NN} = 0, L_{\bar{K}} = 0$

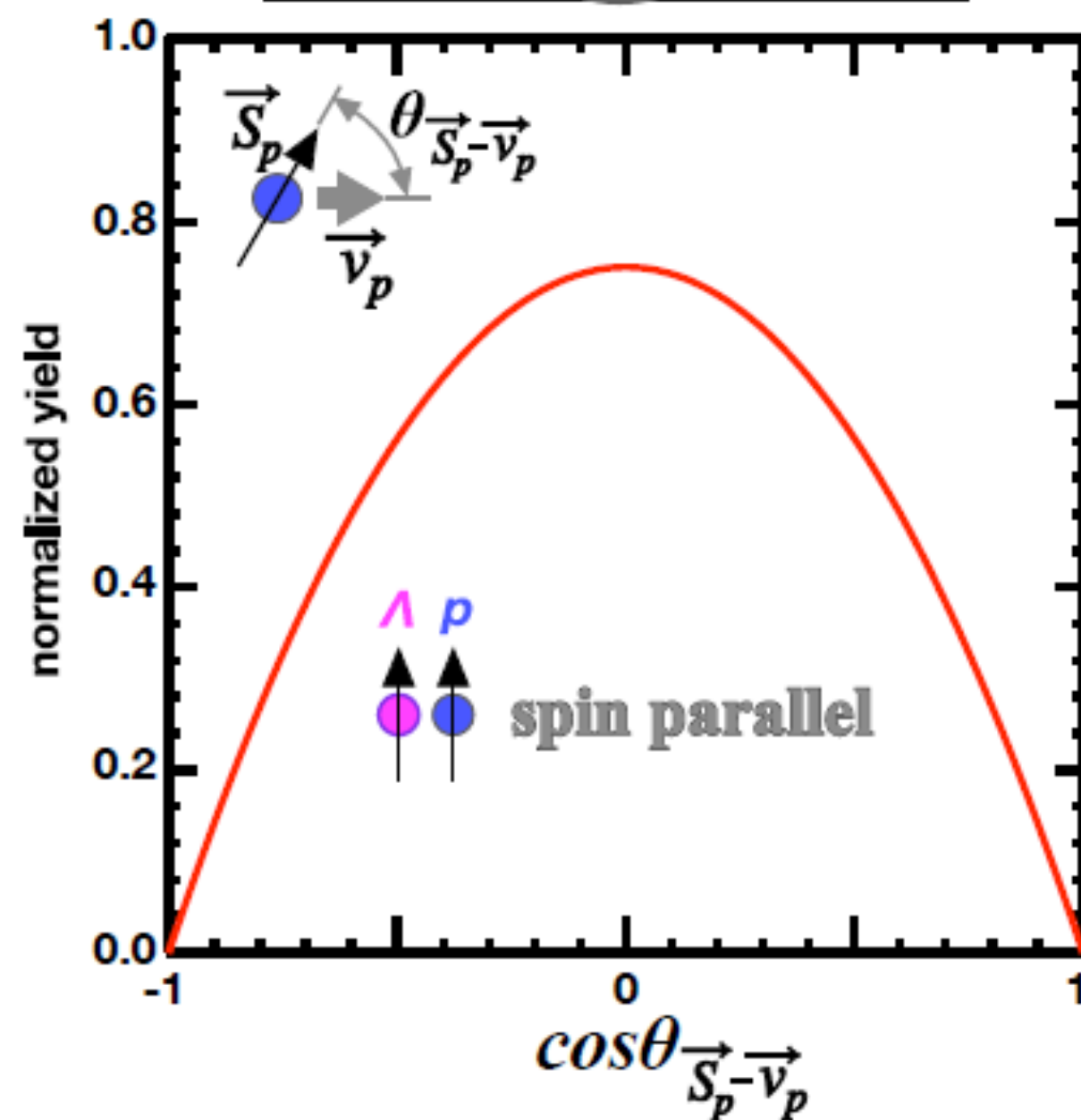
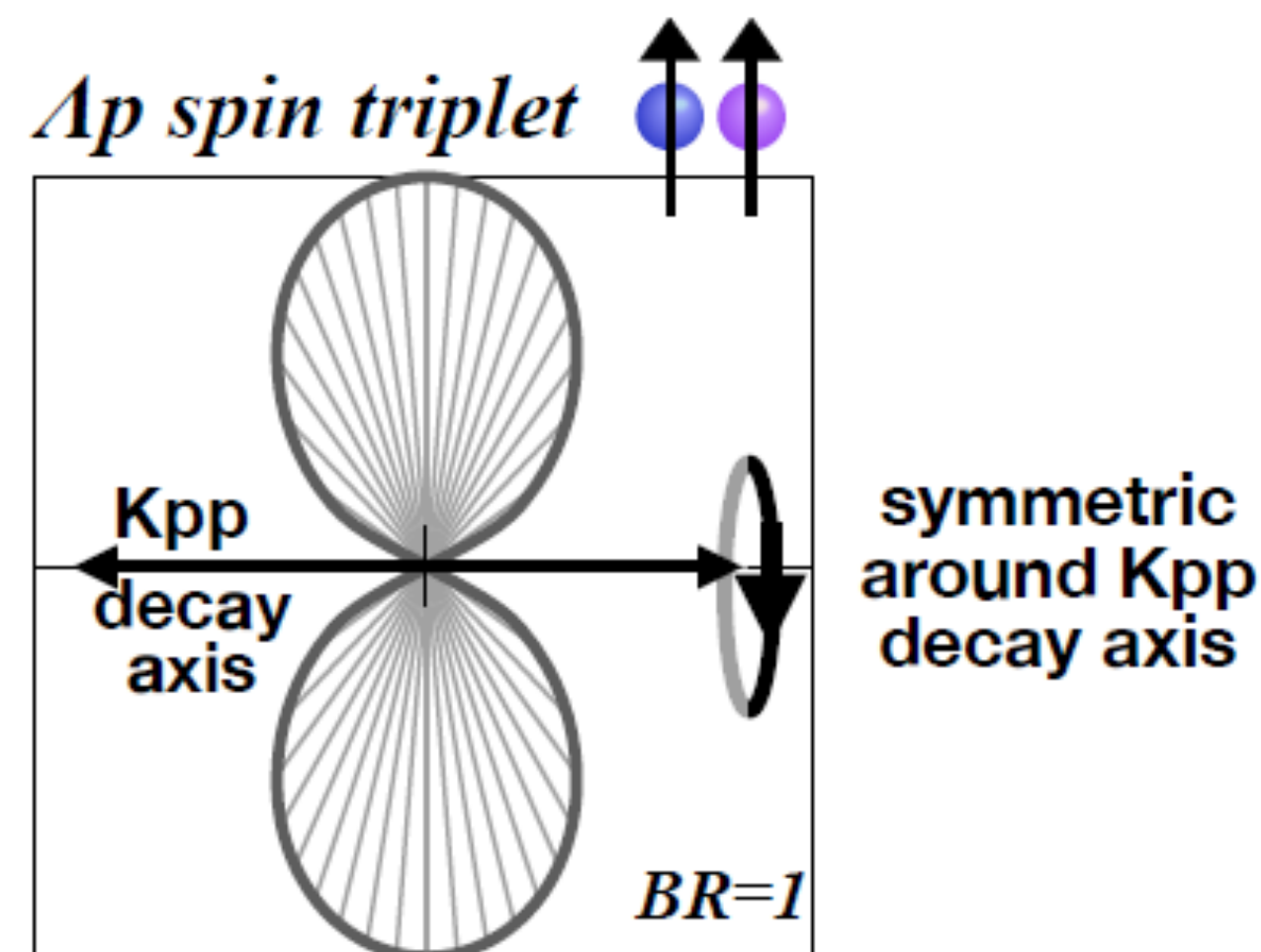

$\bar{K}NN : J^P = 1^-, I = 1/2: I_{NN} = 0, S_{NN} = 1, L_{\bar{K}} = 0$

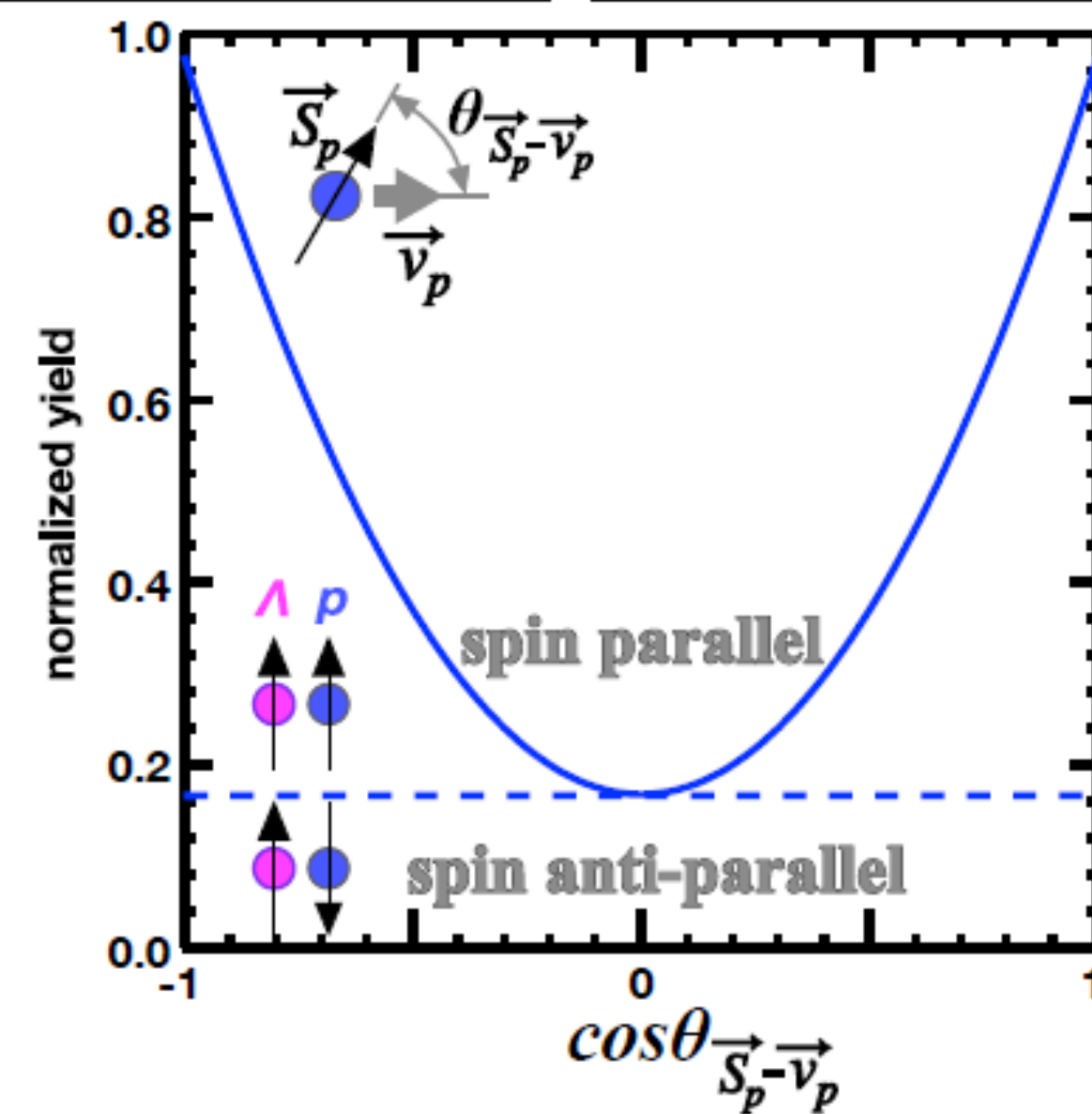
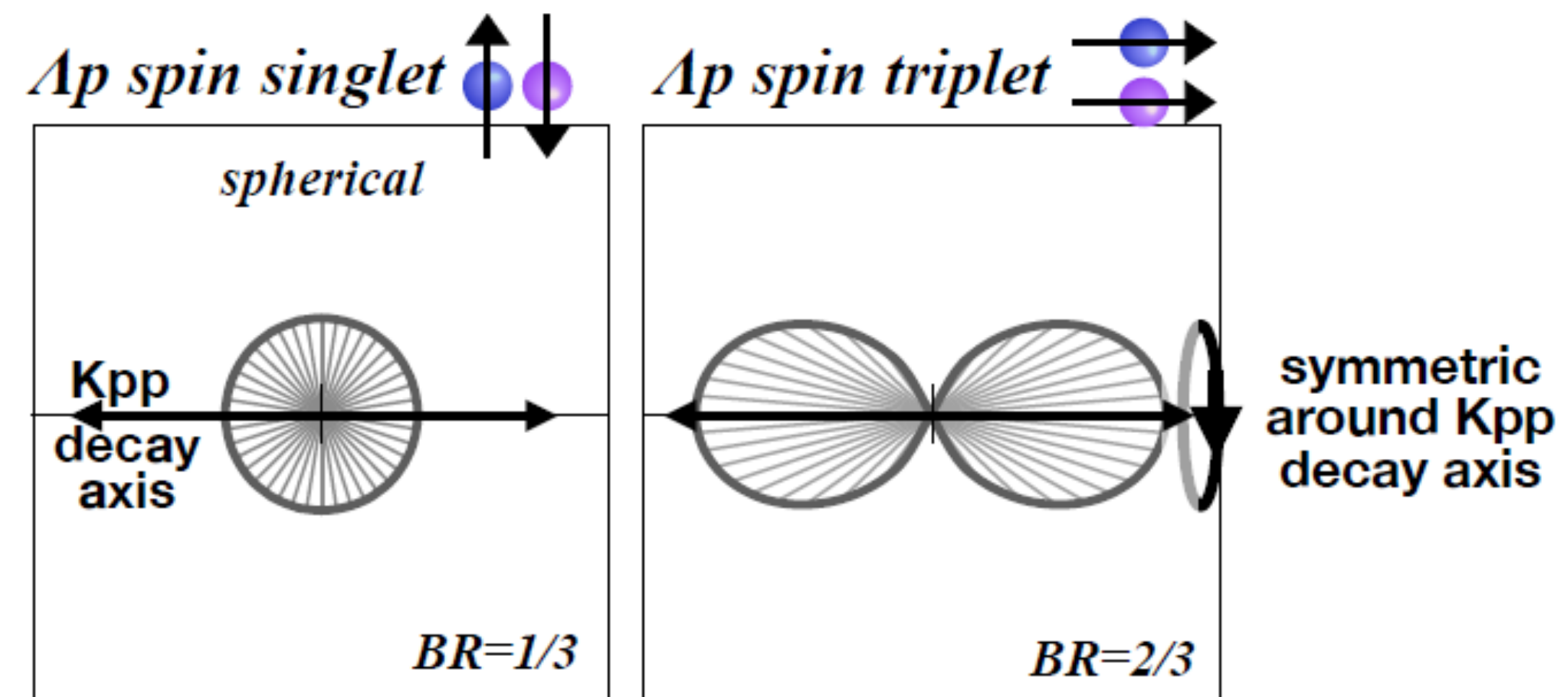

How to measure spin-spin correlation

- spin asymmetry measurement using $\Lambda \rightarrow p\pi^-$ & p-C(H) scattering–
- p-C(H) scattering sensitive only on ϕ asymmetry*

$$\vec{S}_{\Lambda}^{o(\Lambda \rightarrow p\pi^-)} \approx \vec{v}_p^{(\Lambda \rightarrow p\pi^-)} \text{ (in } \Lambda\text{-CM)}$$

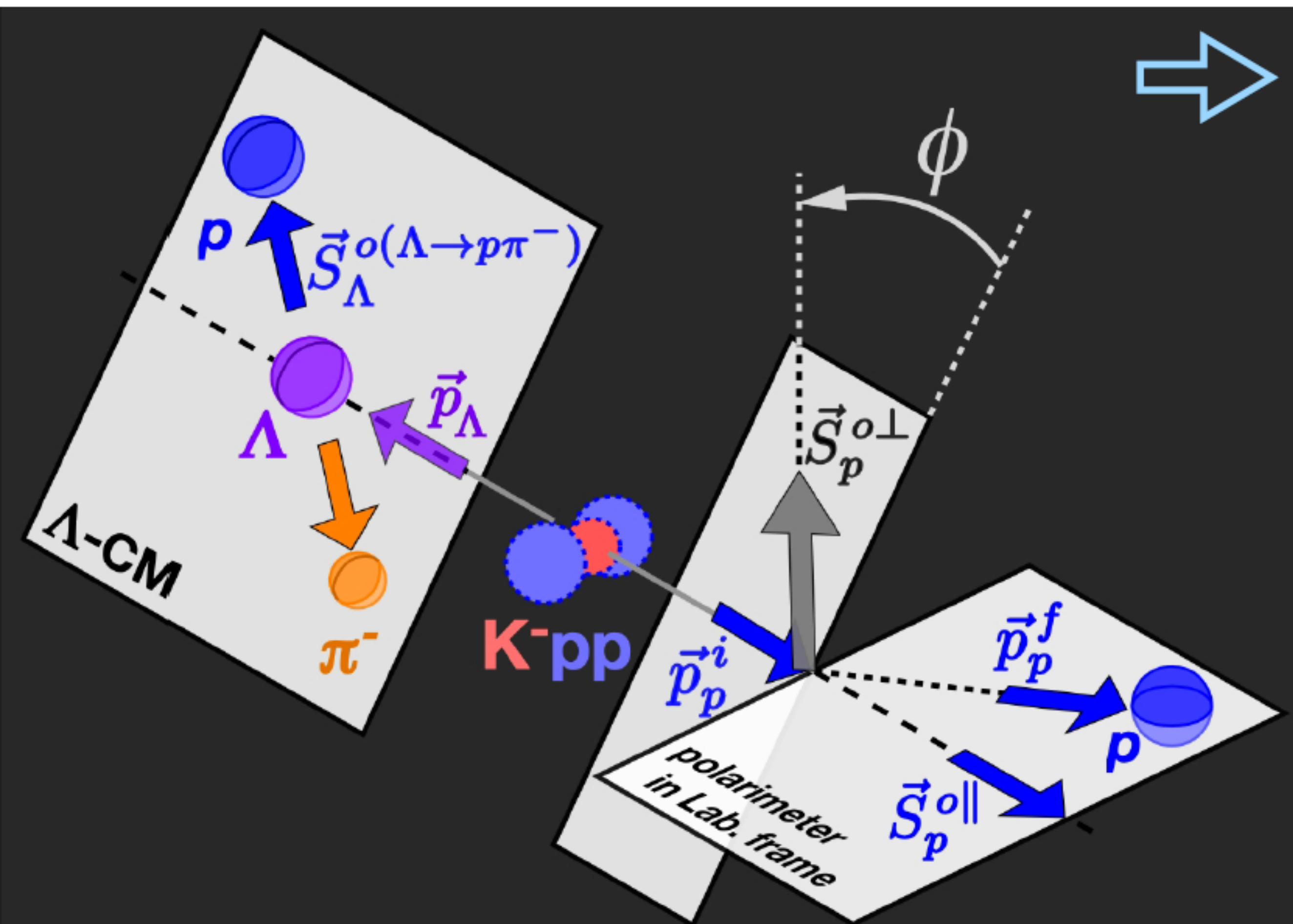

$$N(\phi) d\phi \propto (1 + r \cdot \alpha_{\Lambda p} \cos \phi) d\phi$$

r : scaling factor

$$r = A_{\Lambda} \cdot A_{pC} \cdot \vec{S} \cdot \vec{S}^{\parallel} \cdot c_{conv}$$

A_{Λ} : Λ asymmetry parameter

A_{pC} : proton spin-analyzing-power
on carbon (and on p)

$\vec{S} \cdot \vec{S}^{\parallel}$ ($\equiv \vec{S}_p \cdot \vec{S}_p^{\parallel}$) : spin sensitivity
referring to motional axis

c_{conv} : convolution coefficient
between two asymmetries

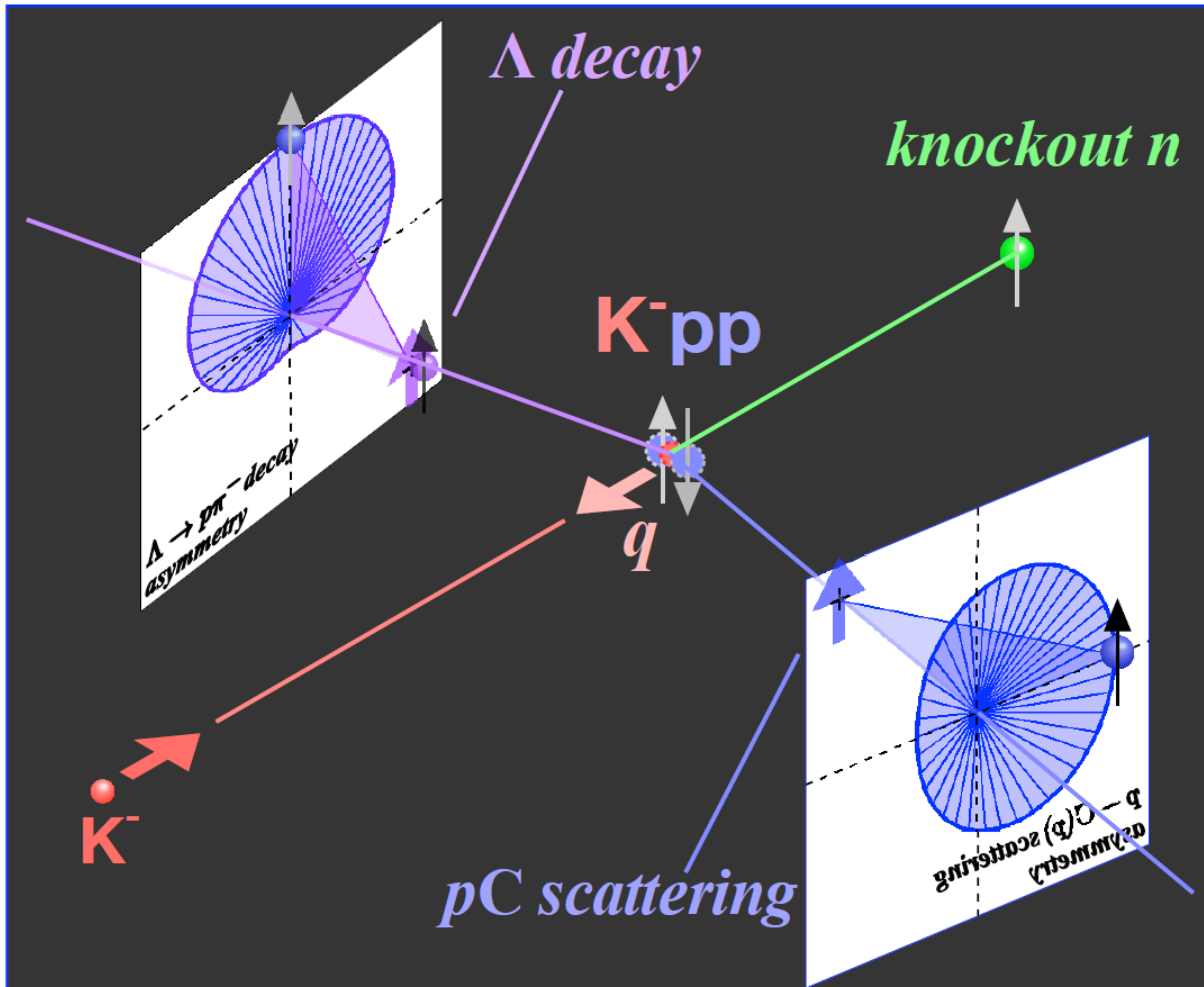

Λp spin-spin asymmetry

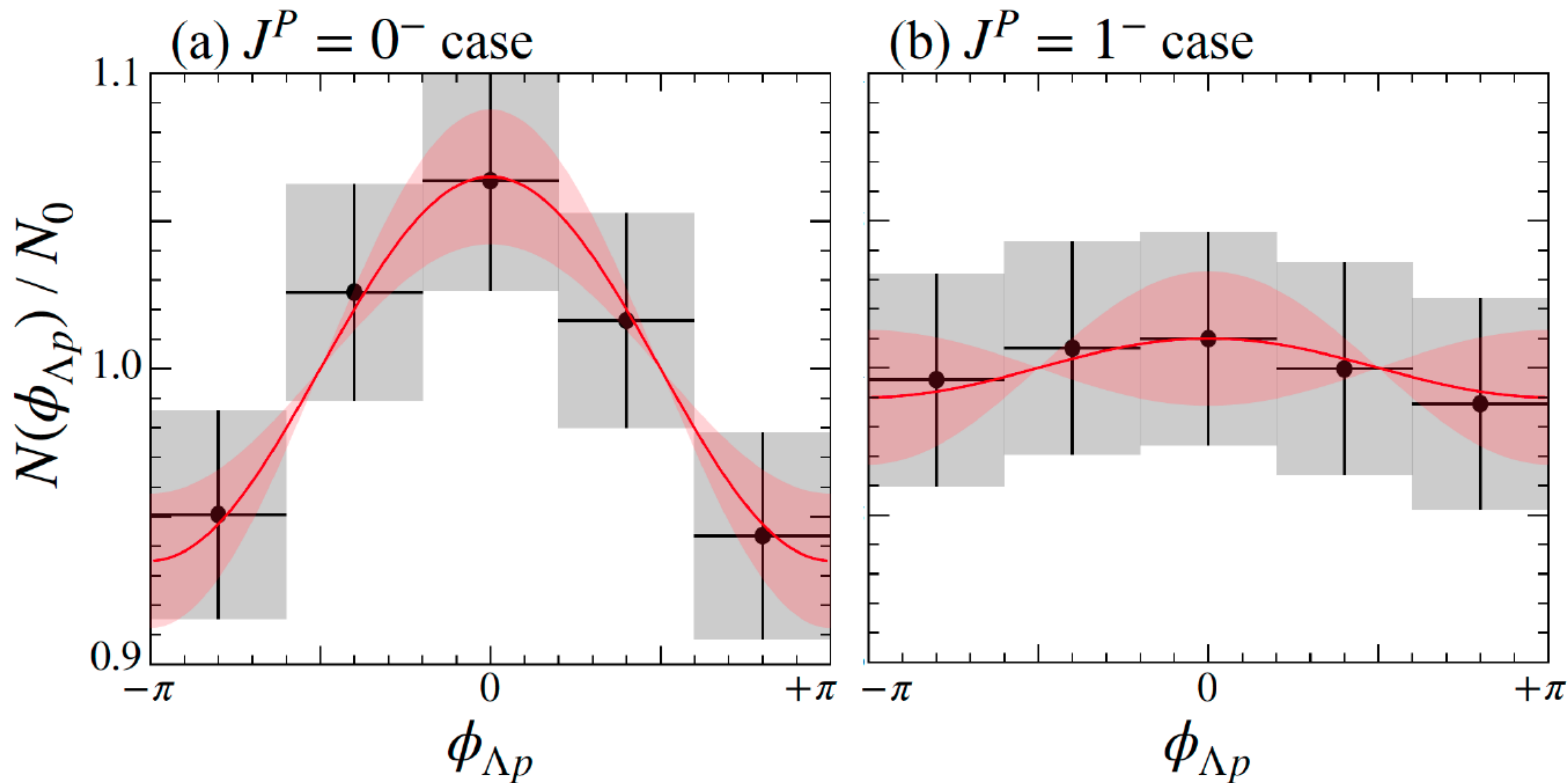

Superconducting Solenoid Magnet

SHI FA-50
(air cooling) RDE-418D4

35

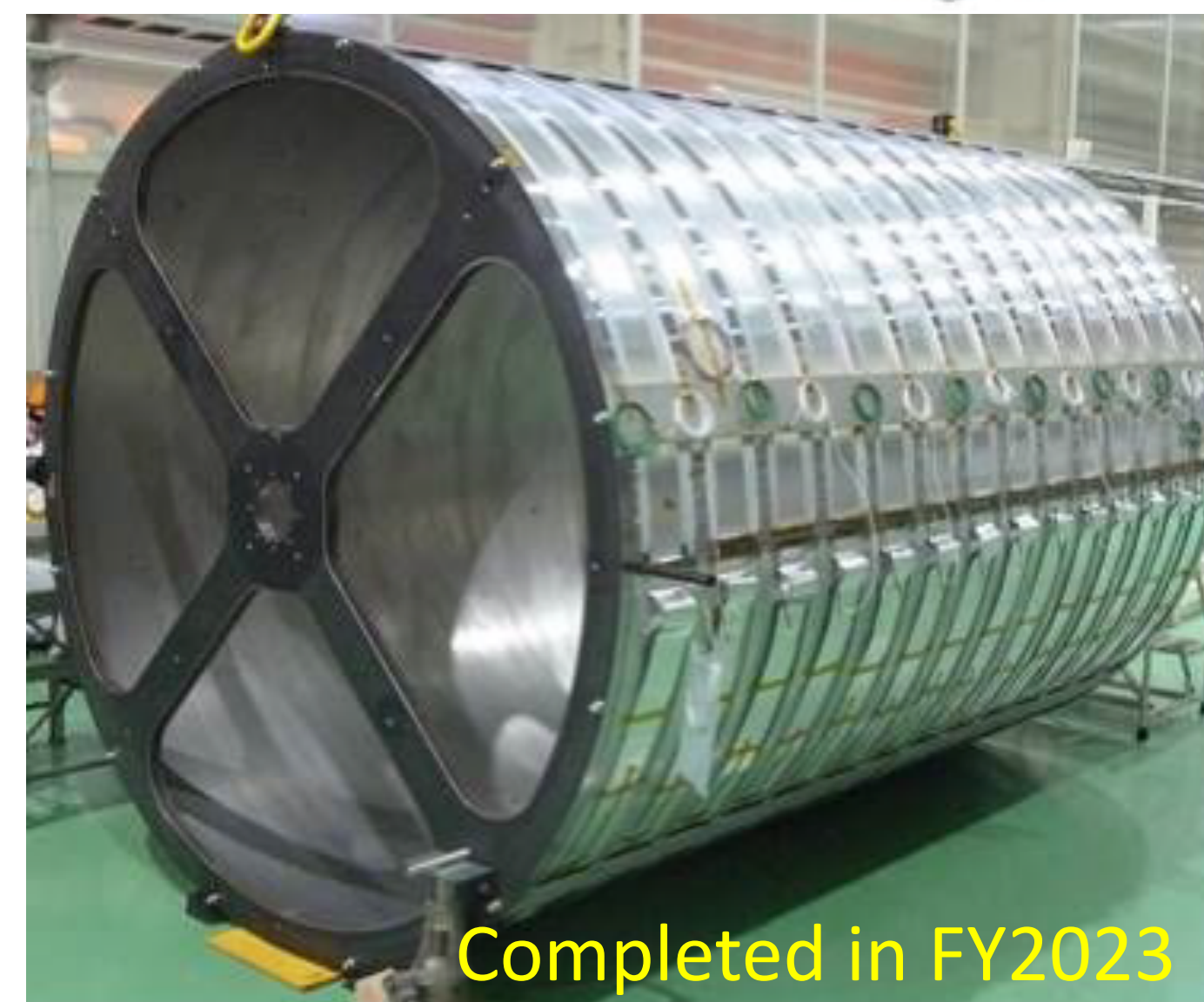

- Same design as “the detector solenoid magnet” for COMET-I

being constructed in cooperation with the J-PARC Cryogenics Section

- 3.3m x 3.3m x 3.9m, ~108t in total
- Max. field of 1.0T @ center
 - 189A – 10V
- NbTi/Cu SC wire, 98km in total
- **Conduction-cooling with GM*3**
- Semi-active quench-back system
- **Will be completed in FY2024**

Cylindrical Drift Chamber (CDC)

- 3 times the length of the existing CDC
 - Gas: Ar/CO₂=90/10
- The same design of the present end-cap
- Readout systems are reused

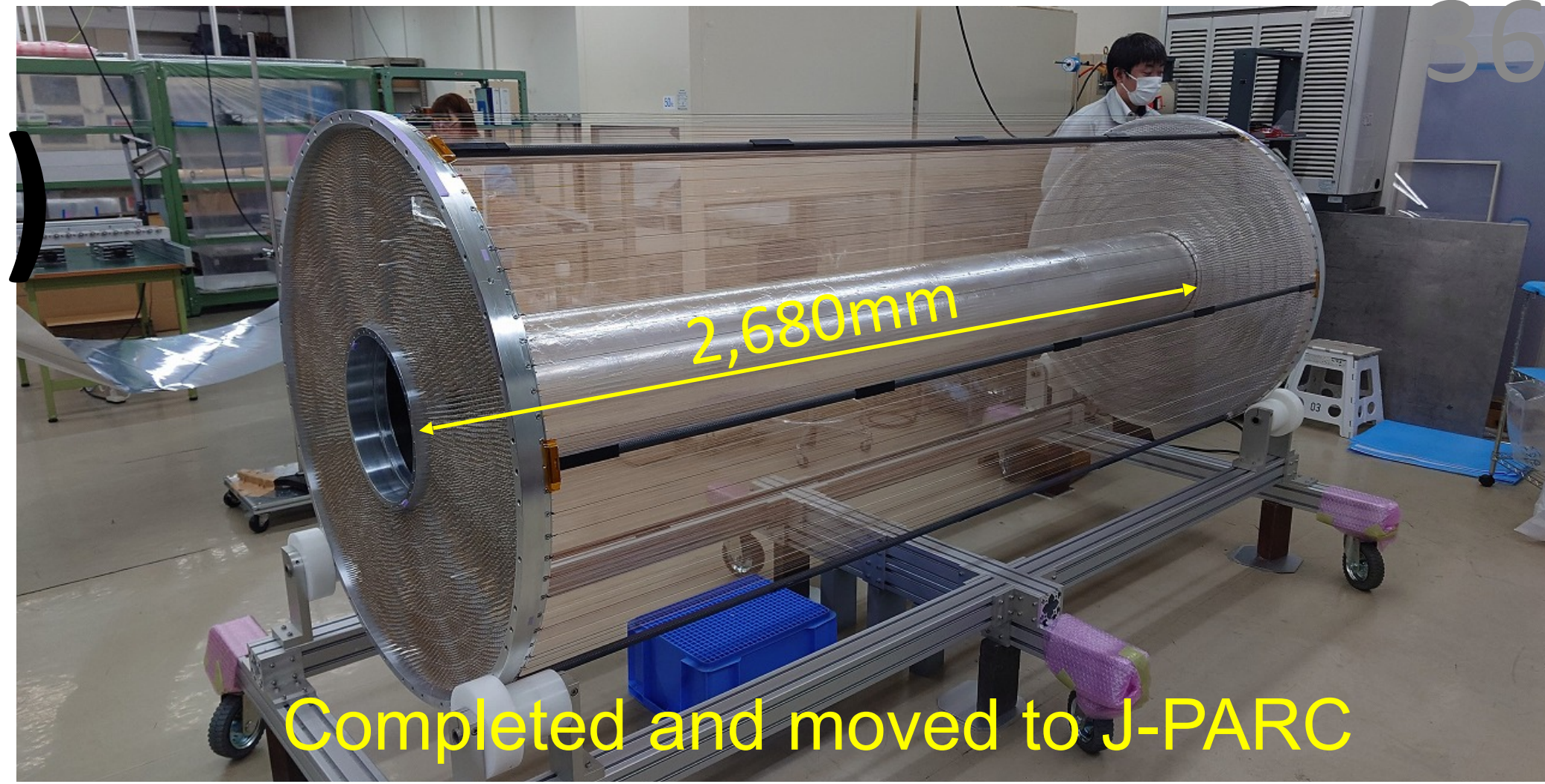

Completed this month, and commissioning will soon start @ J-PARC

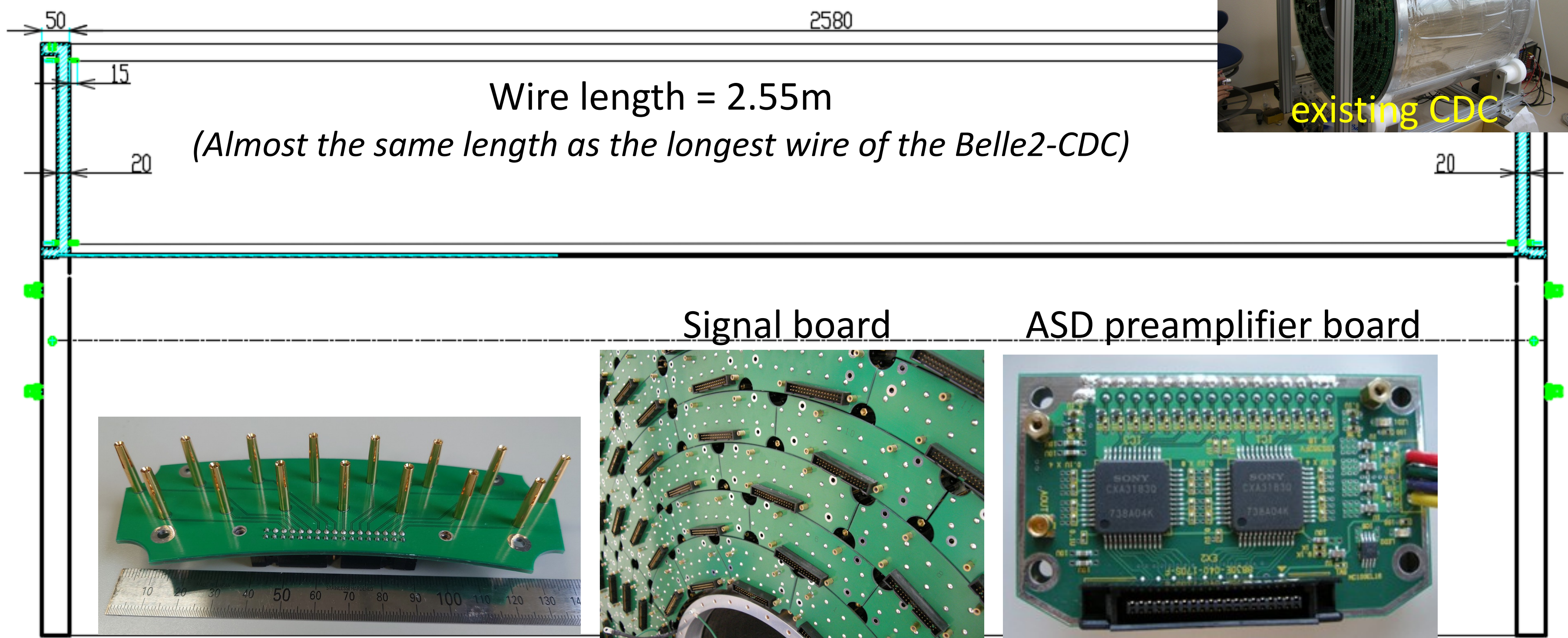
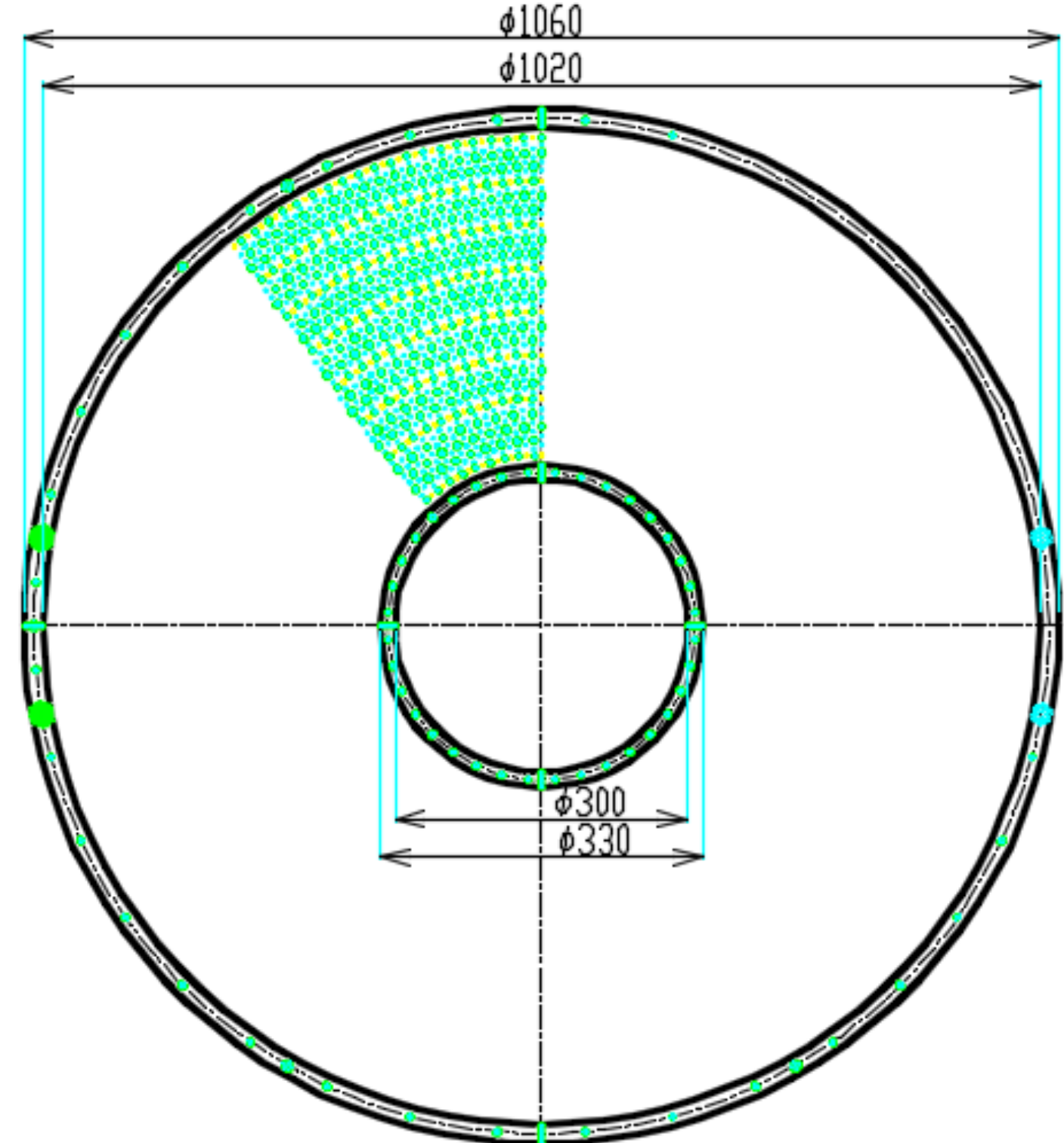
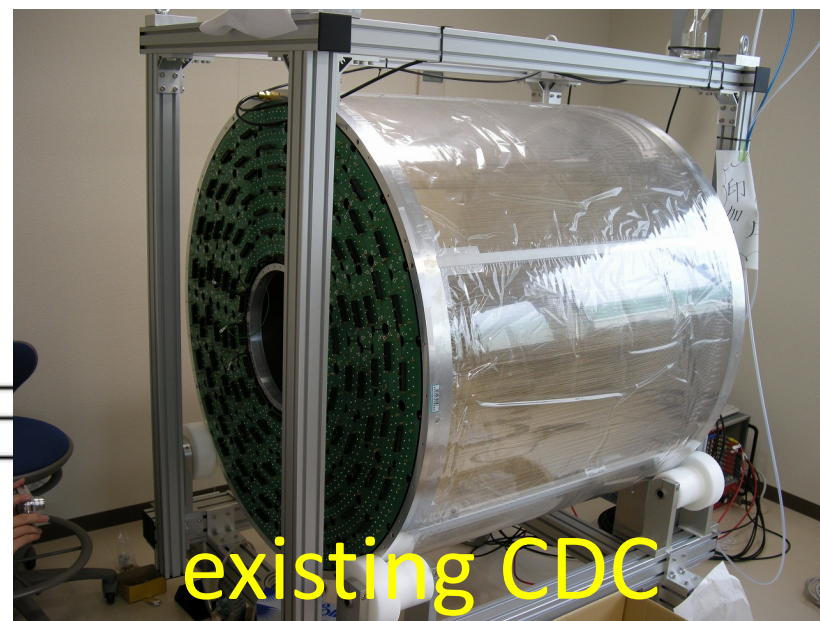

Signal board

ASD preamplifier board

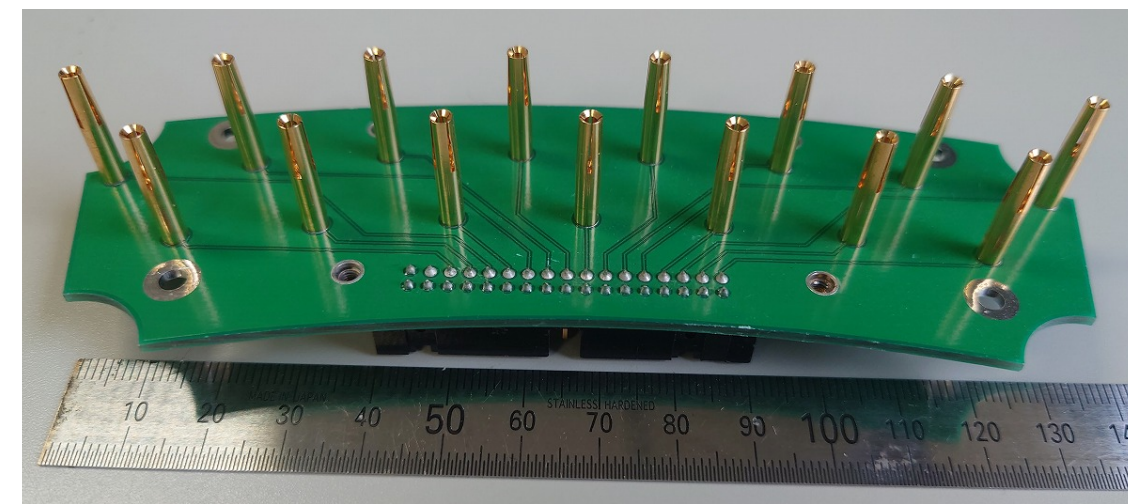

Cylindrical Neutron Counter (CNC)

- scintillator array: 2 layers, 12cm thickness
- Neutron detection efficiency of 12~36%
- 56+80=136 modules
 - ELJEN EJ-200: (T)60mm, (W)60mm, (L)3,000mm
- 1.5-inch FM-PMT [H8409(R7761)]
& MPPC array [S13361-6050AE-04]
- **Will be completed in FY2025**

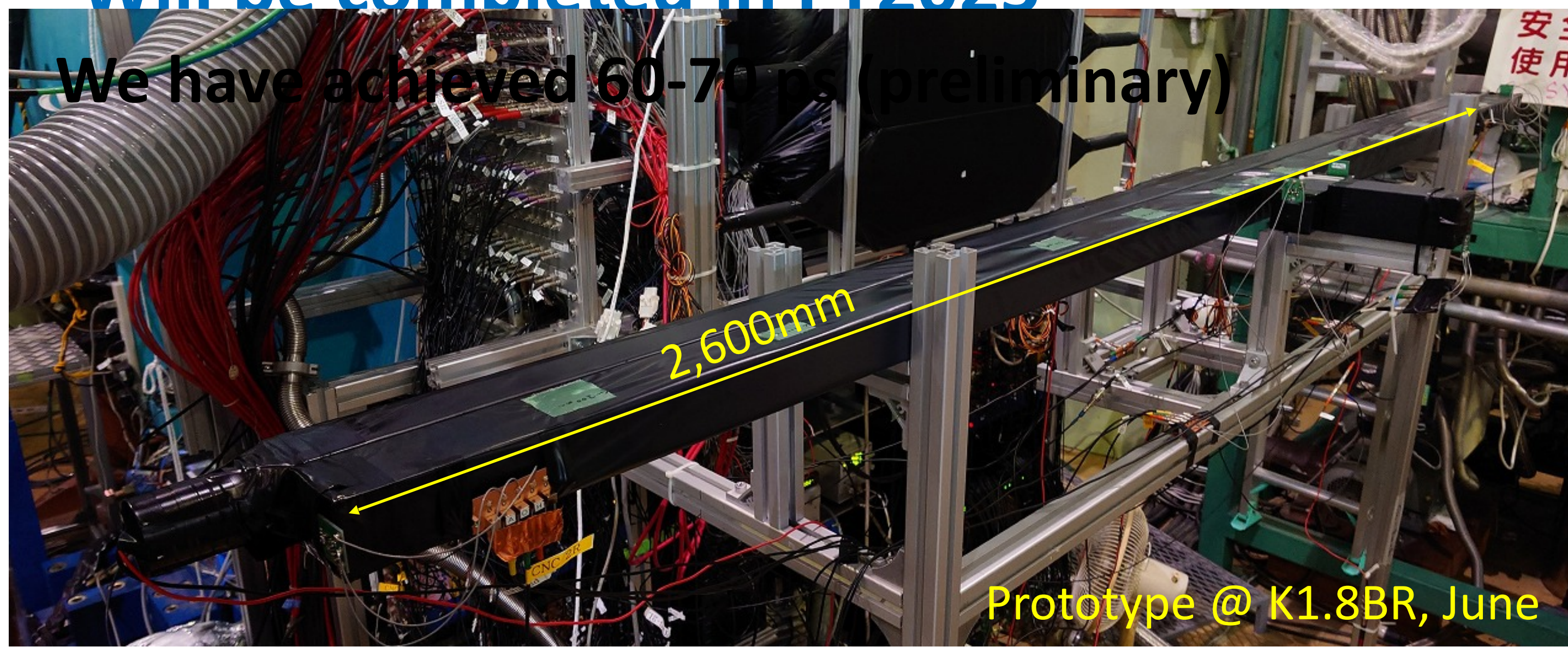
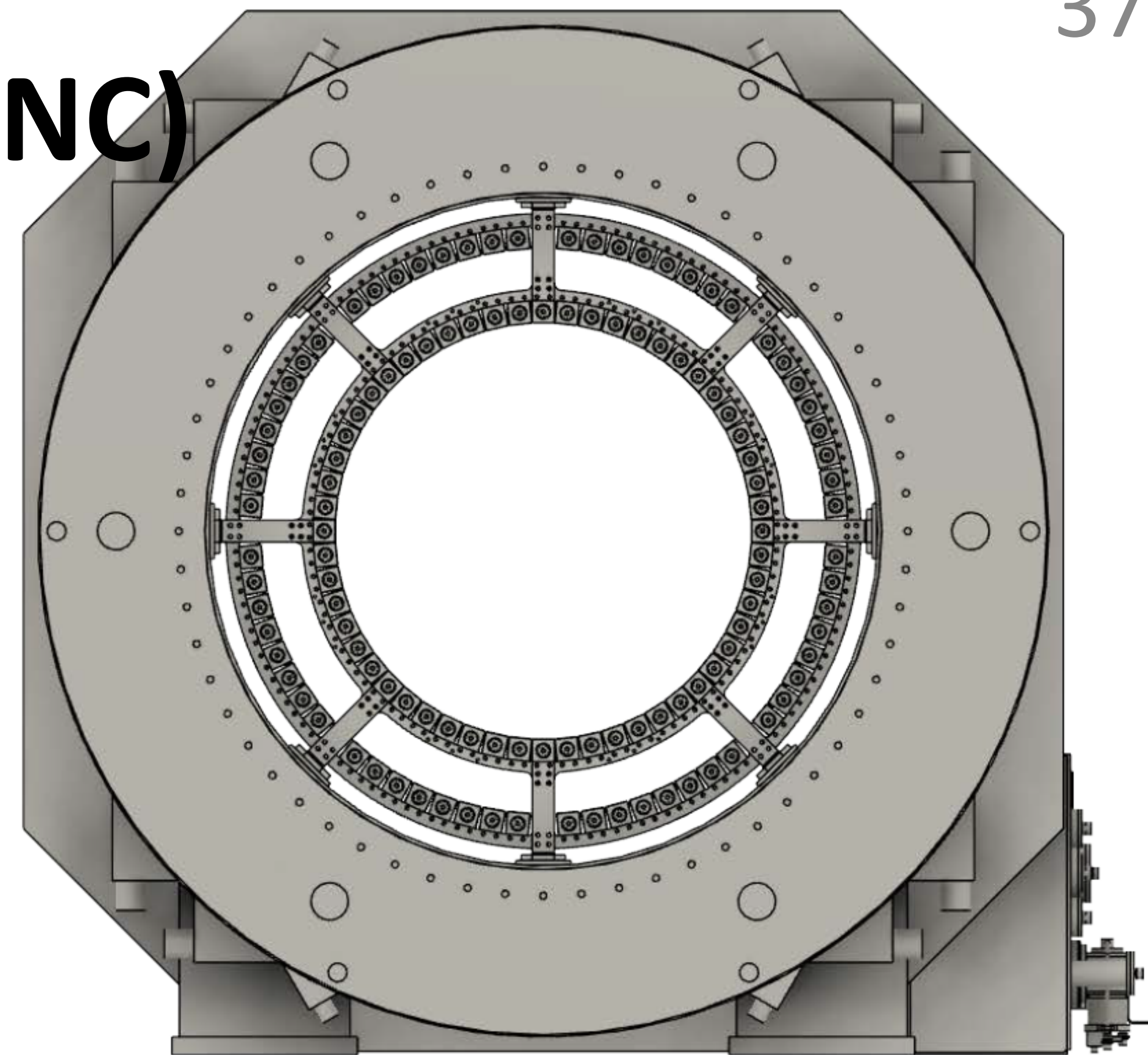

Prototype @ K1.8BR, June

136 scintillators in total

- 56 segments @ r548~608mm
 - 112 FM-PMTs
- 80 segments @ r780~840mm
 - 160 MPPC-arrays

Support Structure

- CNC is supported at upstream, downstream and middle position
 1. pillars are mounted on the inner cylinder of the magnet
 2. ring structures are installed on the pillars
 3. each module is mounted on the ring structures
- CDC is installed by inserting a long frame bar into the center of the CDC and magnet

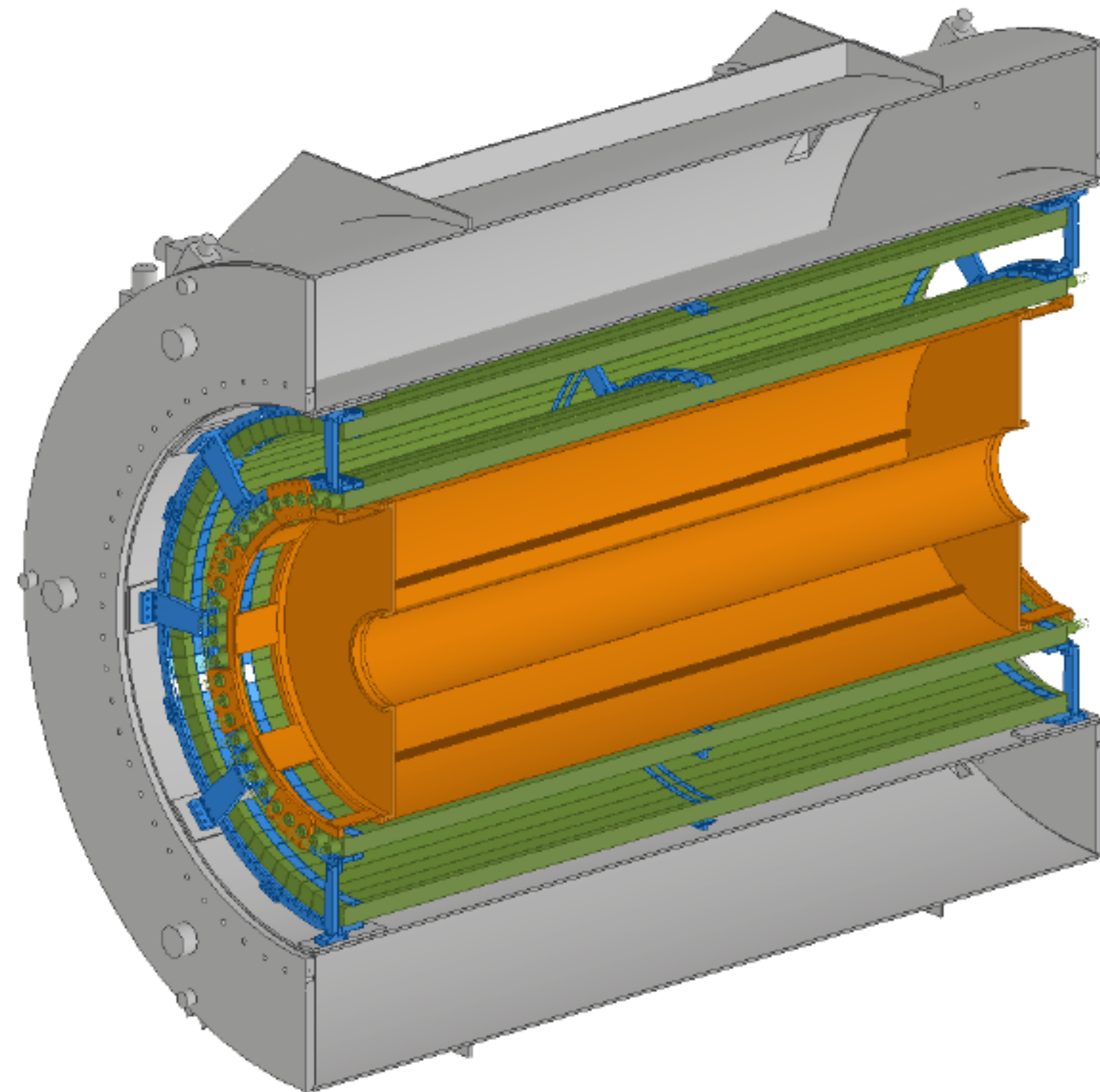
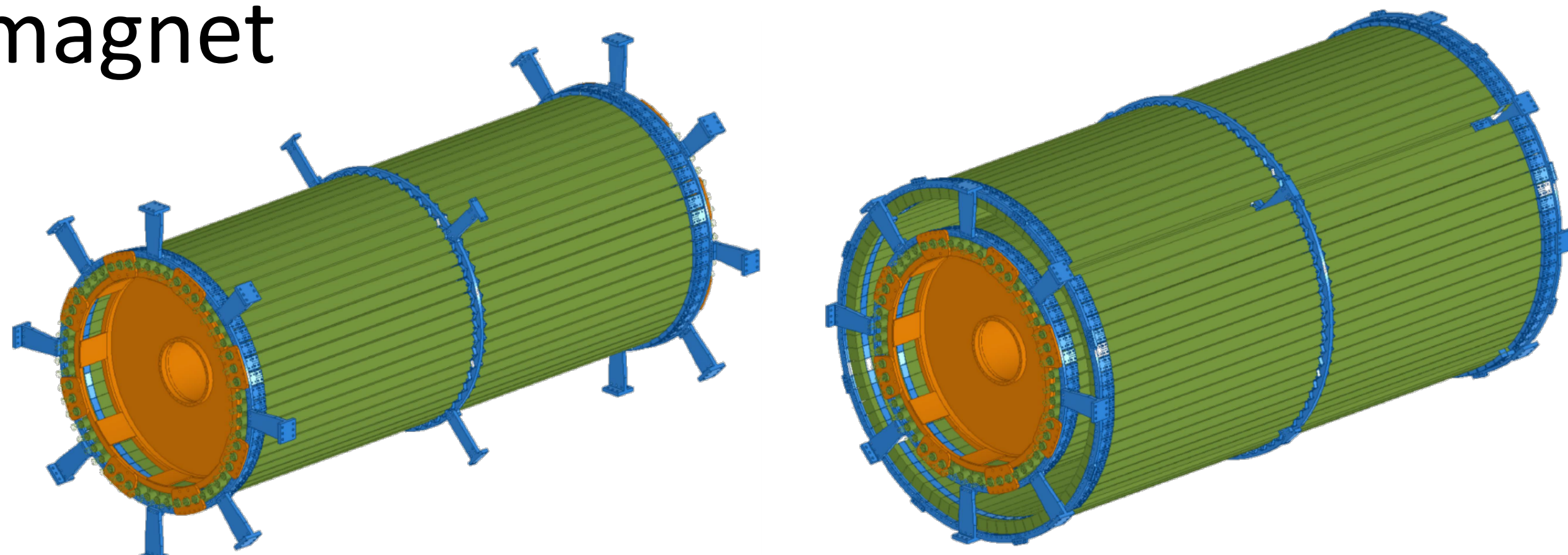

Will be prepared in FY2025-26

Summary of Experimental Status

Negative results

AMADEUS@DAΦNE

$^{12}\text{C}(\text{K}^-_{\text{stopped}}, \Lambda\text{p})$ EPJ**C79**(2019)190

HADES@GSI

$\text{p} + \text{p} \rightarrow (\Lambda + \text{p}) + \text{K}^+$ @ 3.5 GeV

PLB**742**(2015)242

LEPS@SPring-8

$\text{d}(\gamma, \pi^-\text{K}^+)\text{X}$ @ 1.5-2.4 GeV

PLB**728**(2014)616

Positive results

FINUDA@DAΦNE

PRL**94**(2005)212303

$^6\text{Li}/^7\text{Li}/^{12}\text{C}(\text{K}^-_{\text{stopped}}, \Lambda\text{p})$

Multi-NA processes?

DISTO@SATURNE

PRL**104**(2010)132502

$\text{p} + \text{p} \rightarrow (\Lambda + \text{p}) + \text{K}^+$ @ 2.85 GeV

Intermediate $\text{N}^* \rightarrow \Lambda\text{K}^+$?

E27@J-PARC

PTEP(2015)021D01.

$\text{d}(\pi^+, \text{K}^+)\Sigma^0\text{p}$ @ 1.69 GeV/c

Need more data

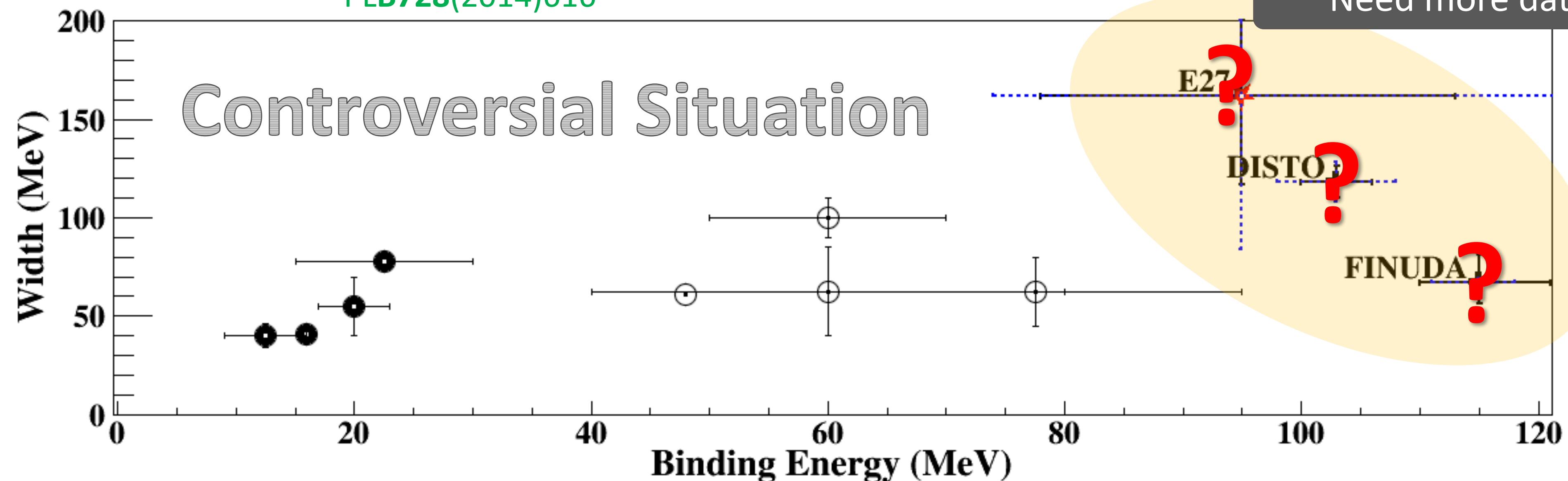

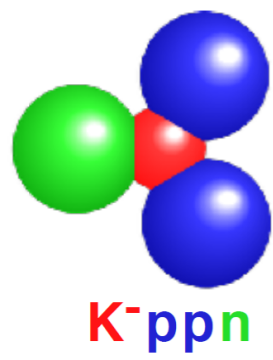

$\bar{K}NNN$ Searches so far

E471/E549@KEK

$^4\text{He}(\text{stopped-}K^-, p/n/\Upsilon d)$

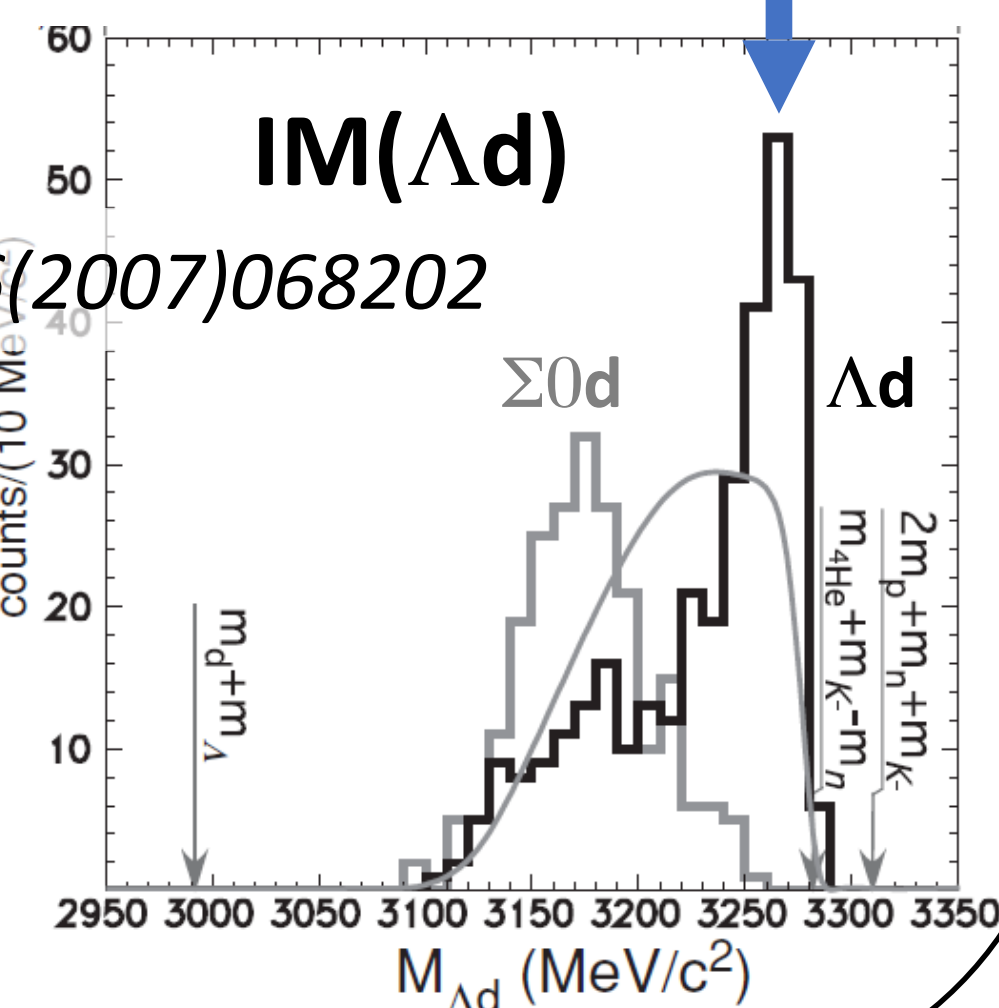
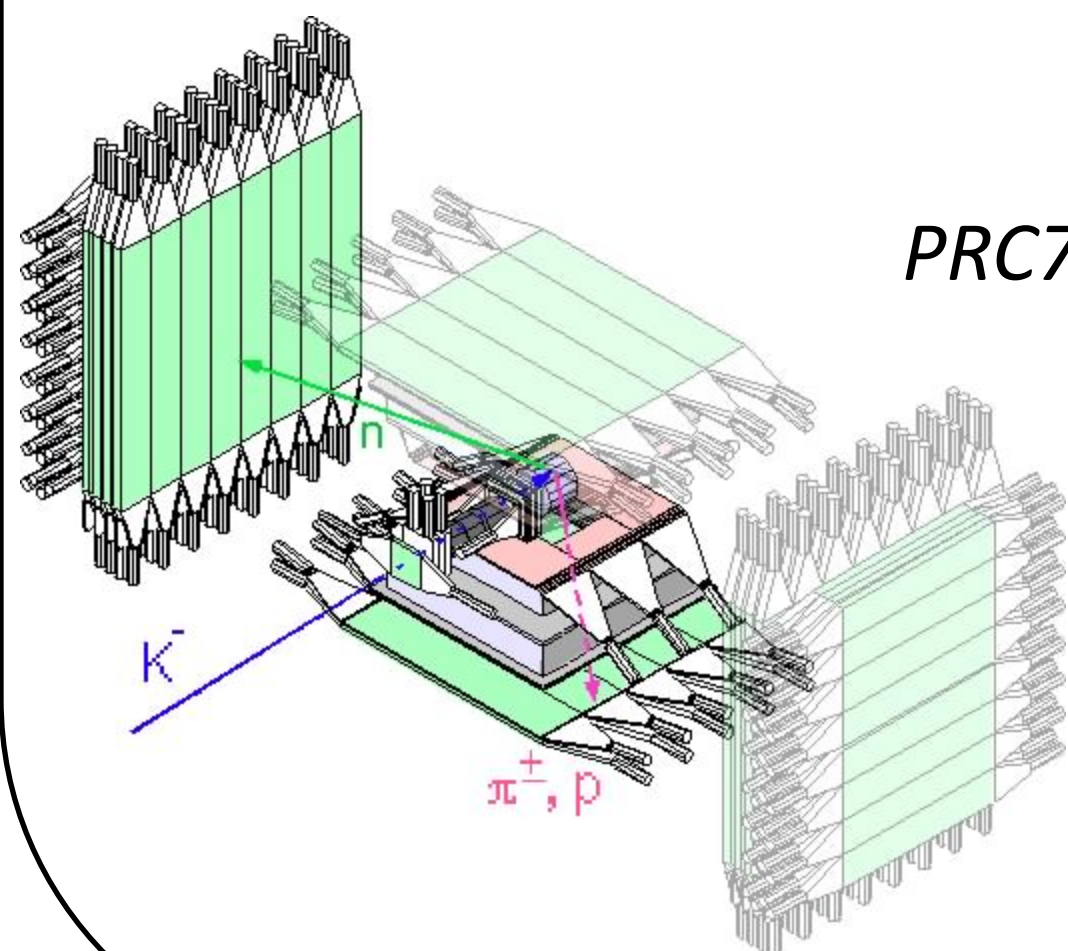
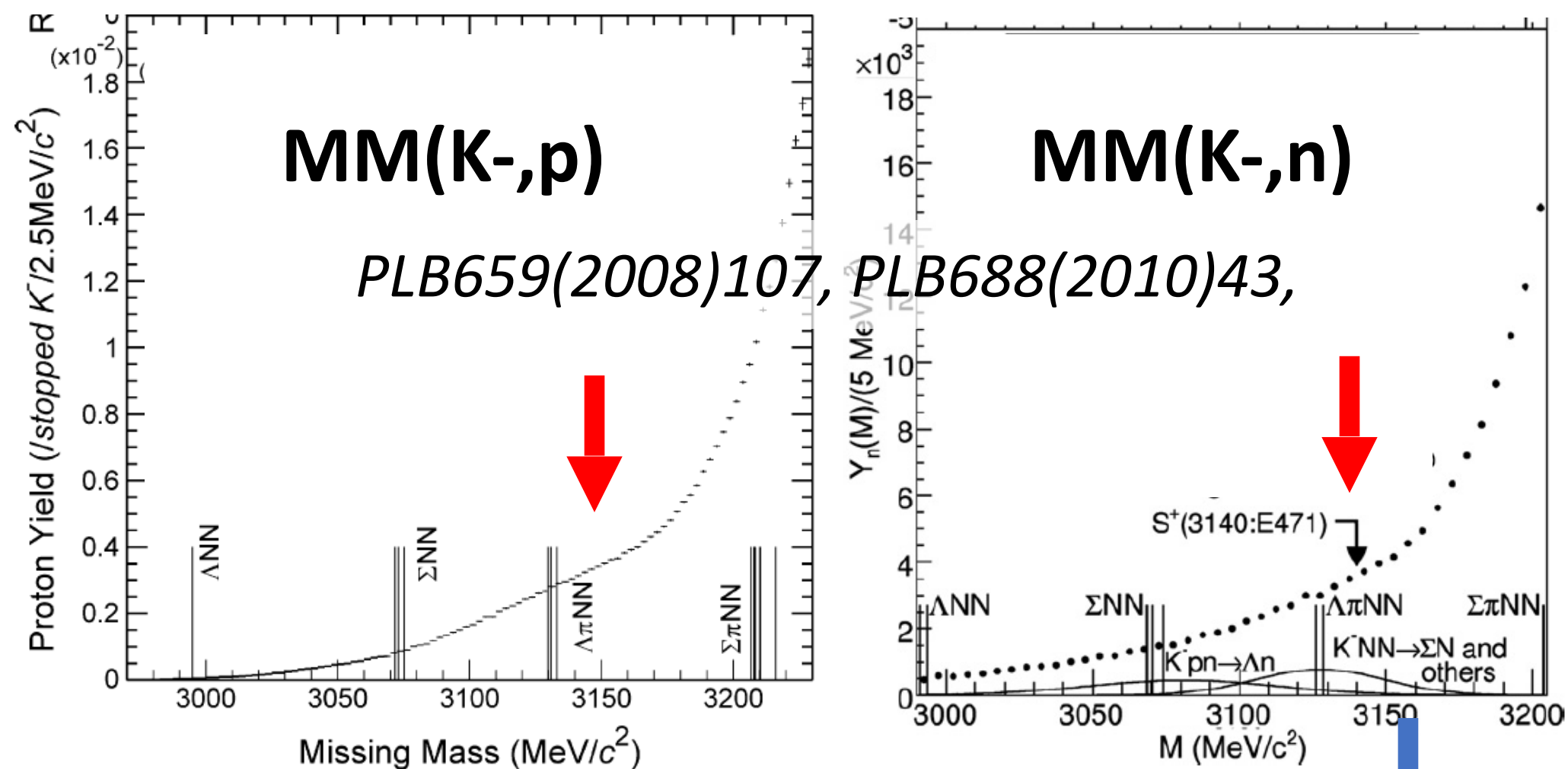

FINUDA@DAΦNE

$\text{Li}/\text{C}(\text{stopped-}K^-, \Lambda d)$

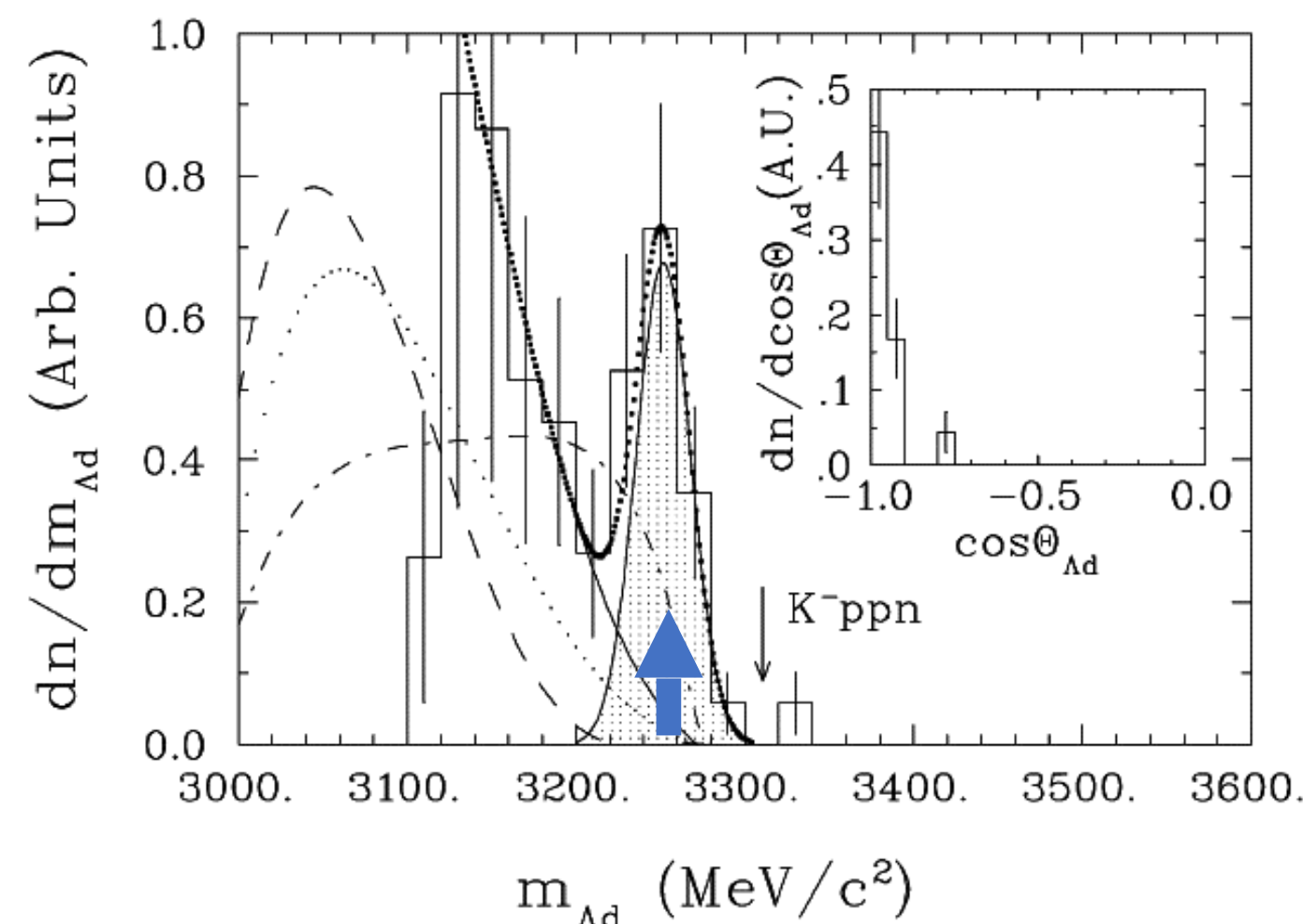

PLB654(2007)80

FOPI@GSI

Λd in Ni+Ni

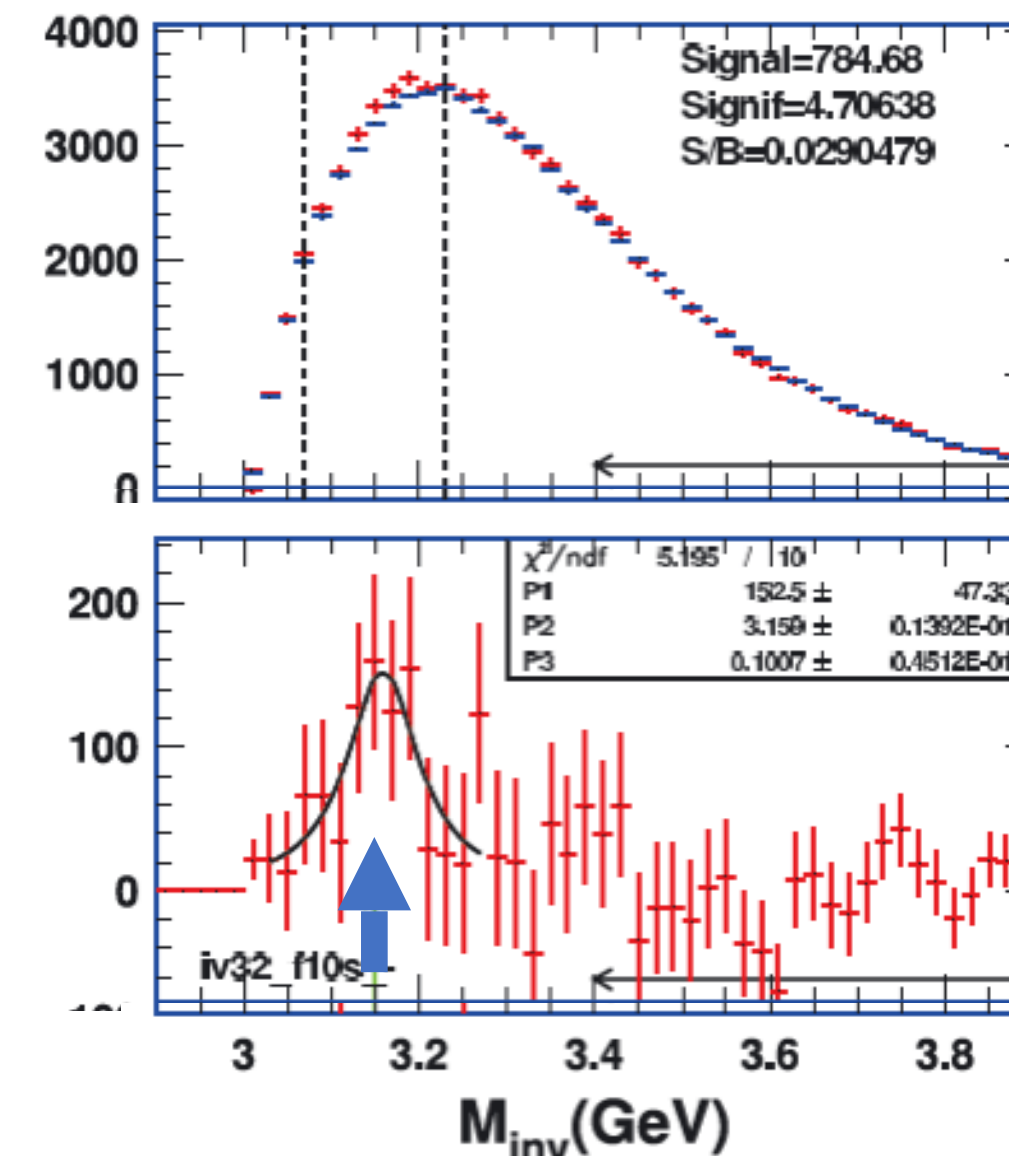

EXA05 Conference (2005)

No conclusive results.

multi-N absorption in stopped-K reaction makes interpretation difficult

カ中間子核探査研究の最近のレビュー

The detail can be found:

— in a review —

$\bar{K}N$ interaction study via kaonic atom

Search for $\bar{K}NN$ nuclear bound state as a natural extension of $\Lambda(1405) \equiv \bar{K}N$

Recent results on \bar{K} bound state

This is a fee-based literature.

Kaonic Nuclei from the Experimental Viewpoint

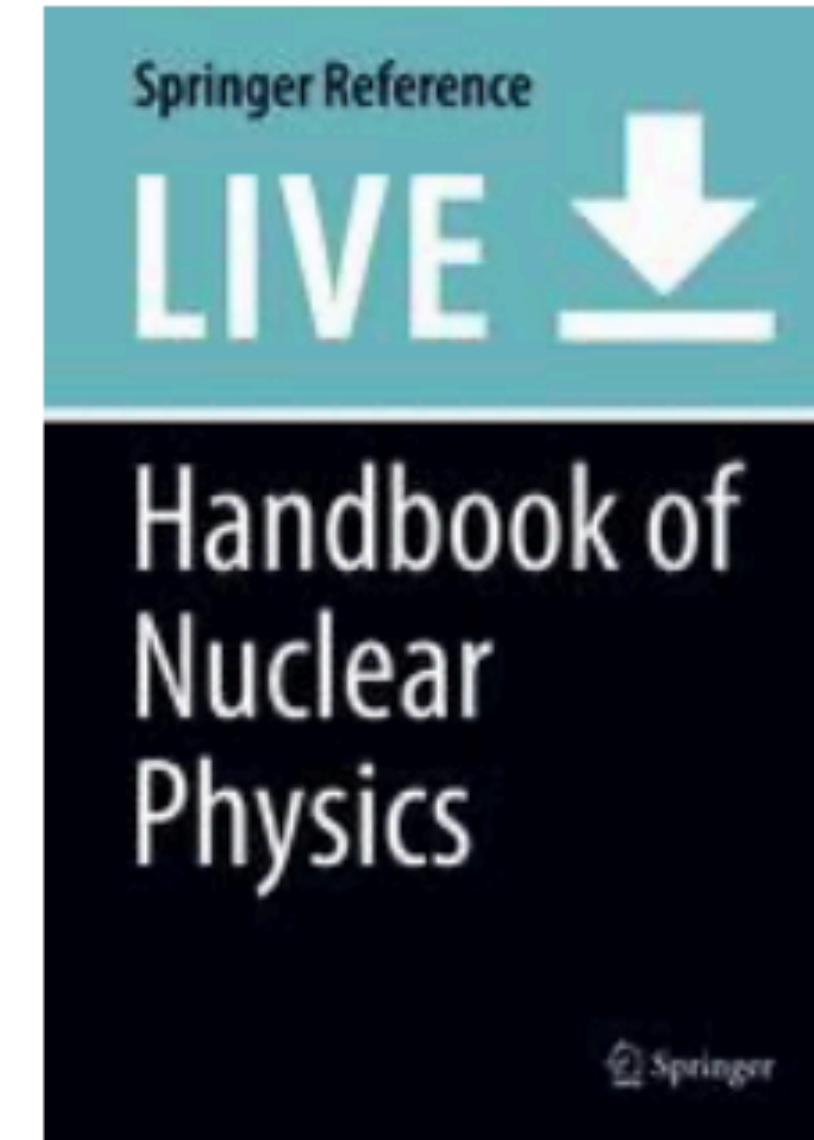

Iwasaki, M. (2022).

Kaonic Nuclei from the Experimental Viewpoint.

In: Tanihata, I., Toki, H., Kajino, T. (eds)

Handbook of Nuclear Physics . Springer, Singapore.

https://doi.org/10.1007/978-981-15-8818-1_37-1

https://link.springer.com/referenceworkentry/10.1007/978-981-15-8818-1_37-1

Proposed K1.8BR Upgrade

設置ビームライン改良計画

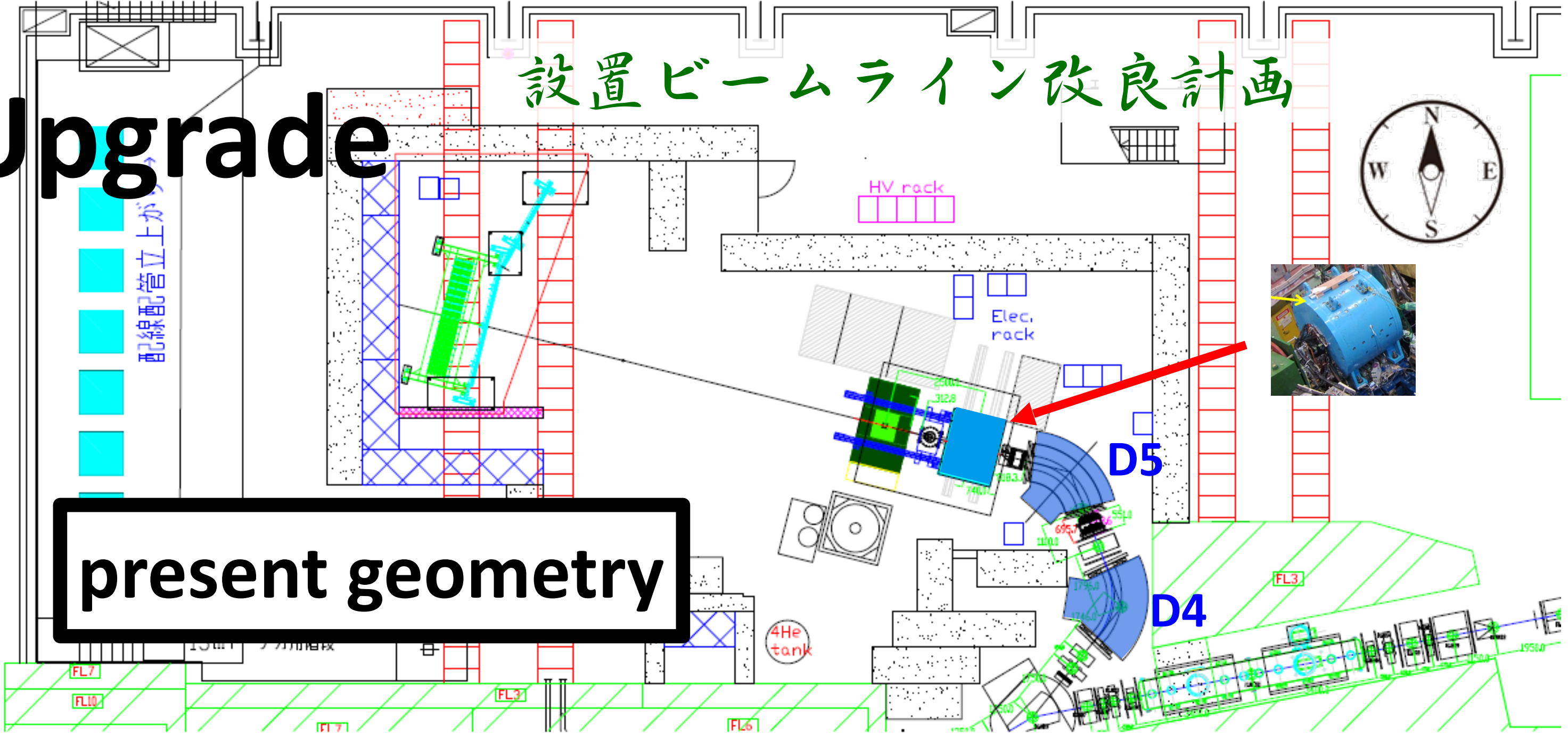

- Shortened beam line to enhance Kaon yield

Shorten the beam line (~2.5m) by removing the final D5 magnet

with π/K ratio ~ 2

Relative beam-line length (m)	@ D5	@ D4
Present CDS	0	-3.7
New CDS	+1.2	-2.5

➤ K- yield increases by **~ 1.4 times @ 1.0 GeV/c**

Proposed K1.8BR Upgrade

設置ビームライン改良計画

- Shortened beam line to enhance Kaon yield

Shorten the beam line (~2.5m) by removing the final D5 magnet

with π/K ratio ~ 2

Relative beam-line length (m)	@ D5	@ D4
Present CDS	0	-3.7
New CDS	+1.2	-2.5

- K- yield increases by **~ 1.4 times @ 1.0 GeV/c**

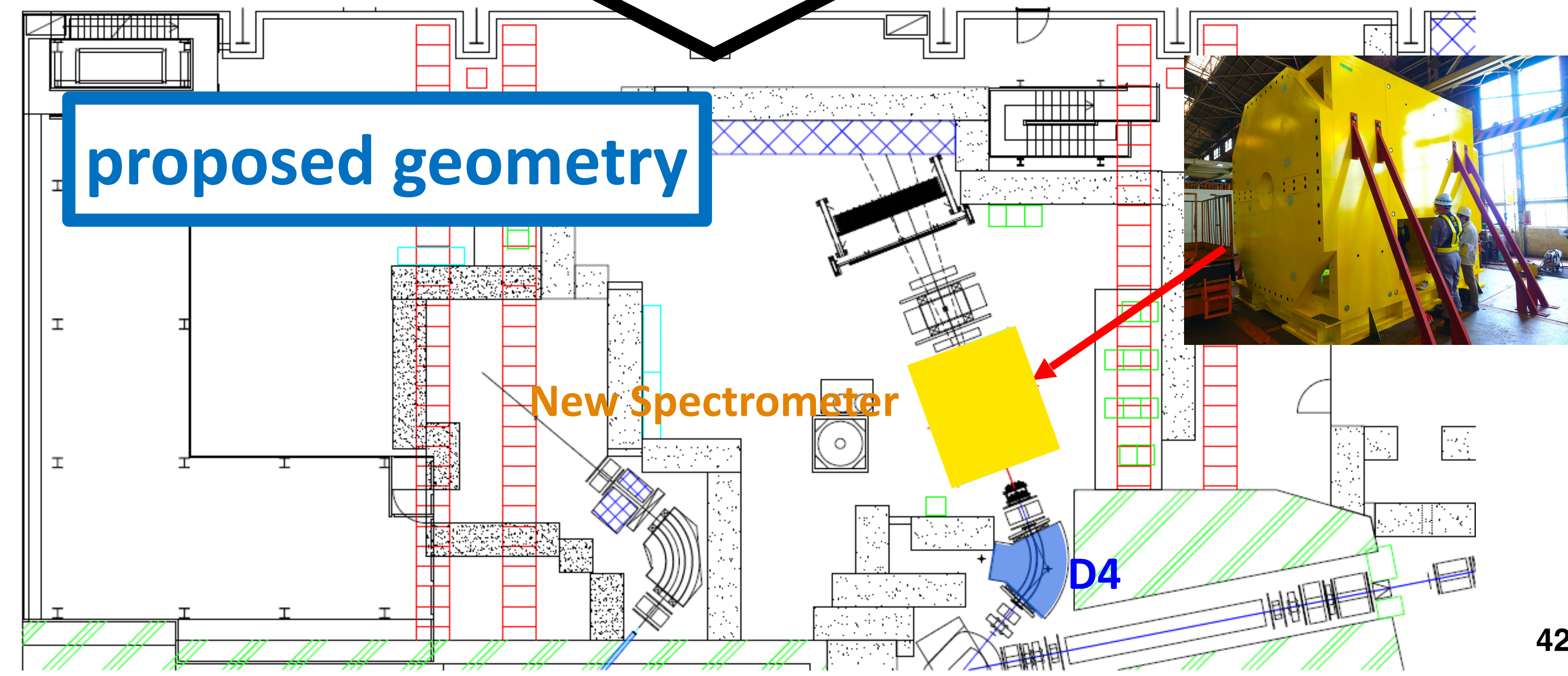
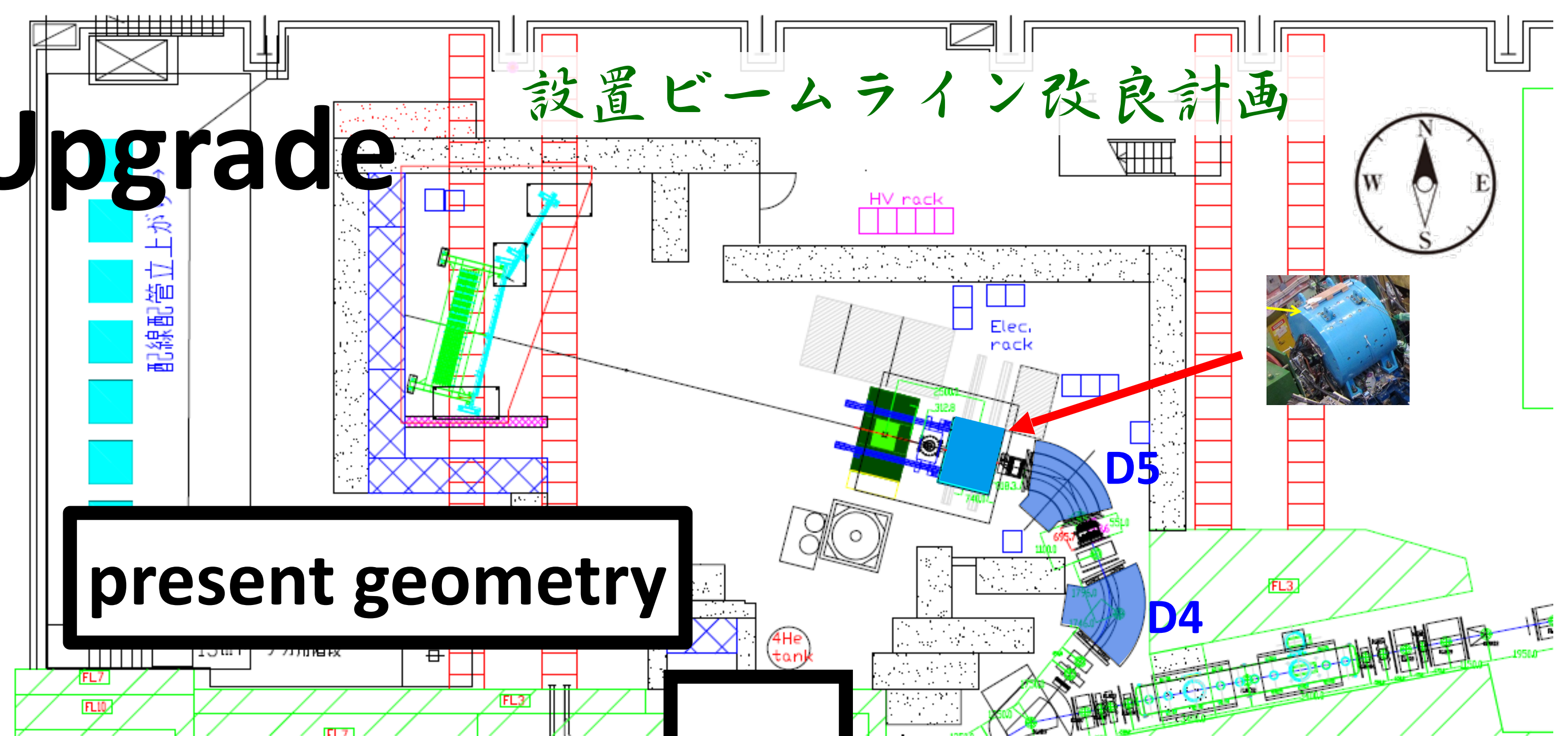

$K^- + {}^3\text{He} \rightarrow (\pi^- \Lambda p) + p$ reaction

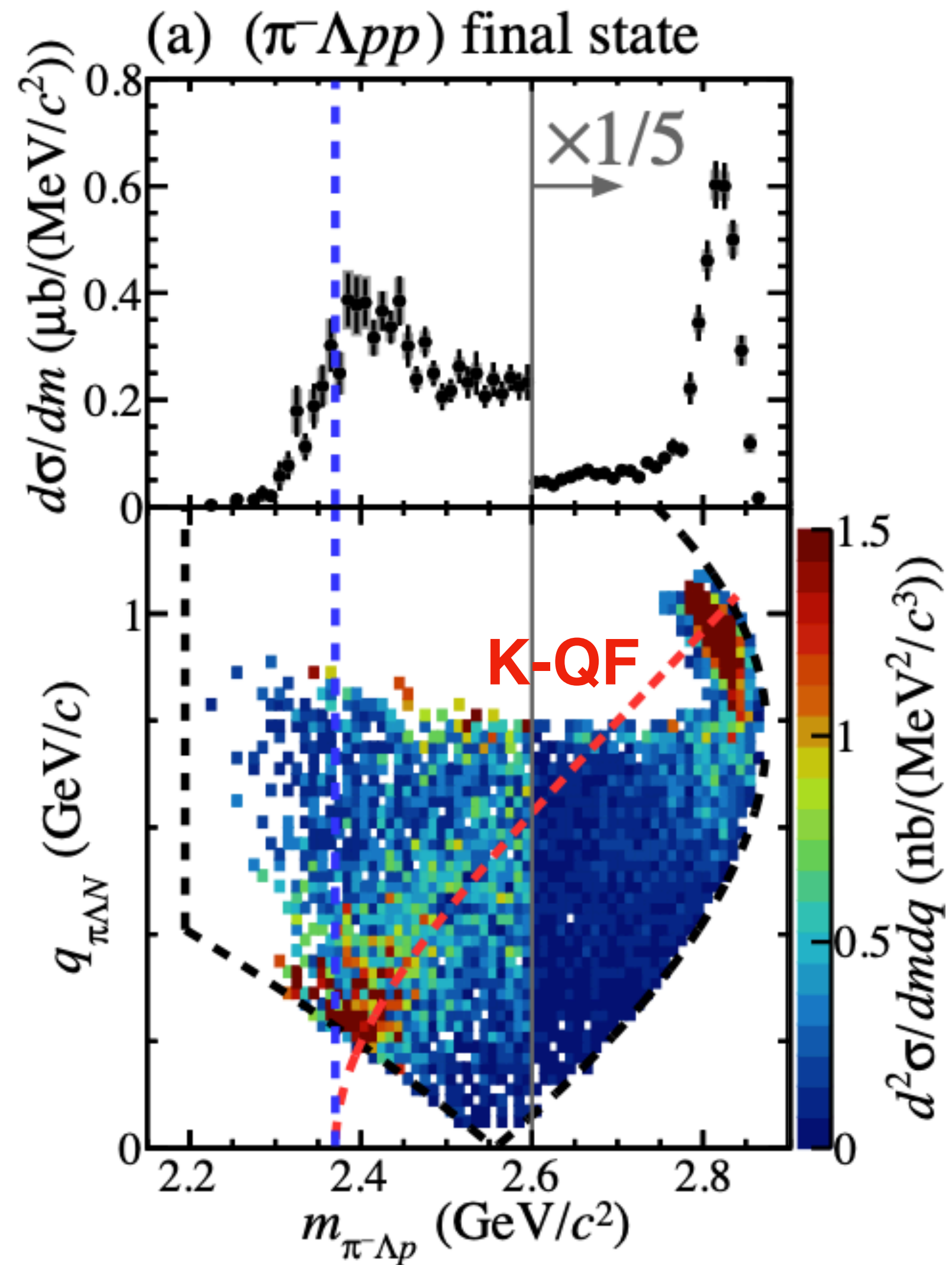

... analyzed by T. Yamaga

$K^- + {}^3\text{He} \rightarrow (\pi^- \Lambda p) + p$ reaction

consistent with $K^- + {}^3\text{He} \rightarrow \Lambda p n$ reaction
branch seems to be order bigger

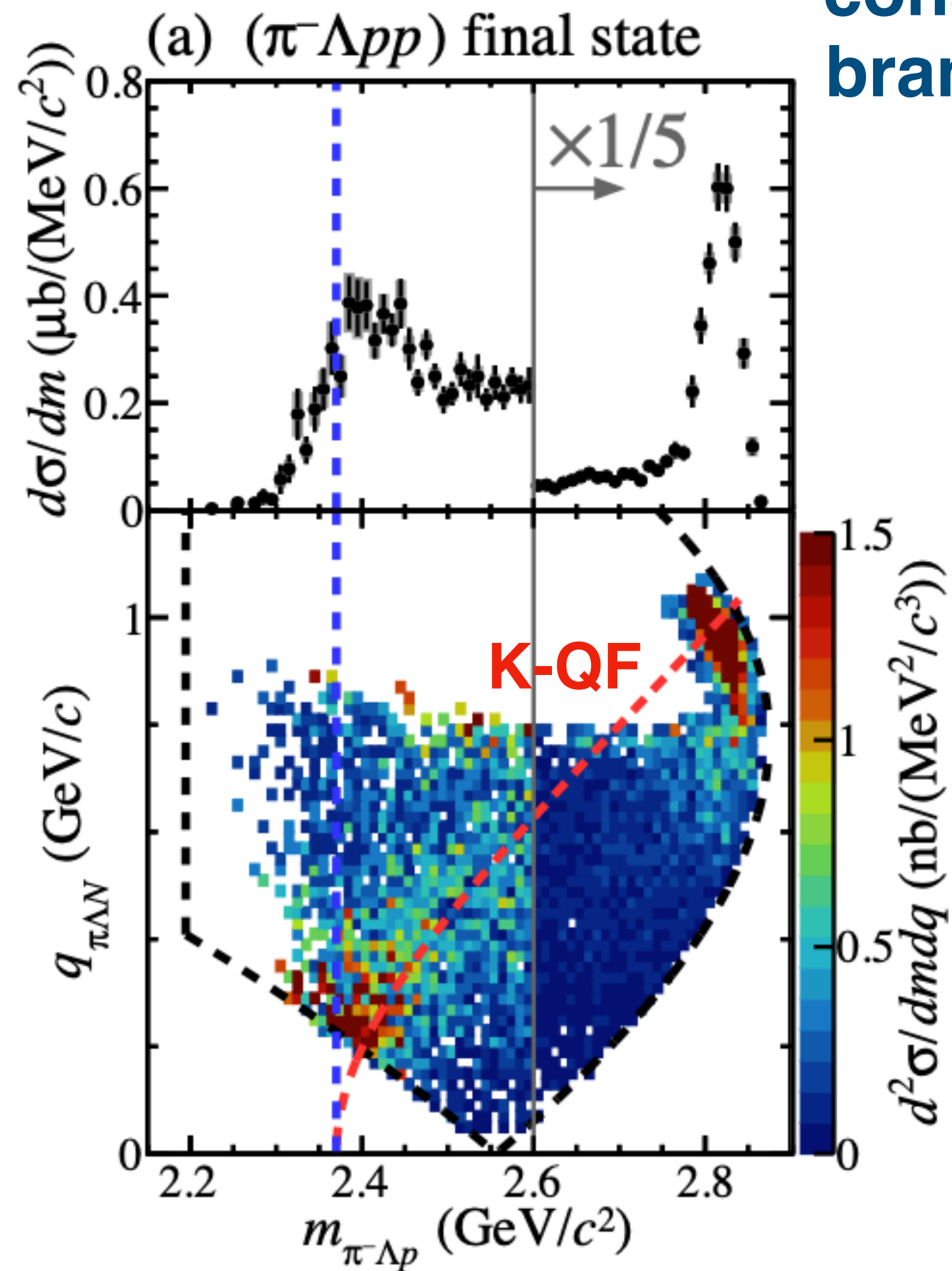

... analyzed by T. Yamaga

$K^- + {}^3\text{He} \rightarrow (\pi^- \Lambda p) + p$ reaction

consistent with $K^- + {}^3\text{He} \rightarrow \Lambda p n$ reaction
branch seems to be order bigger

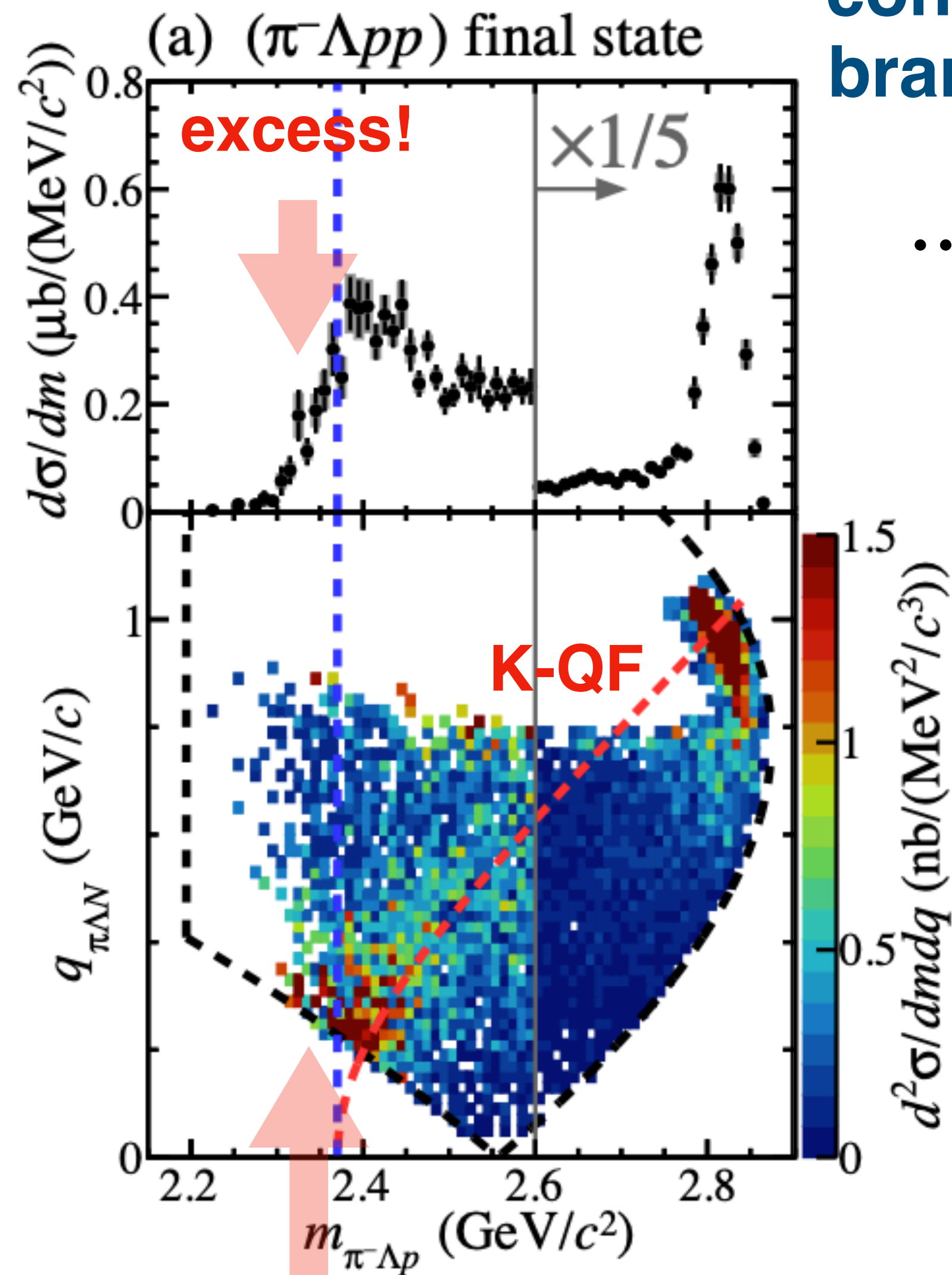

... *excess* is not easy to see ...

... analyzed by T. Yamaga

$K^- + {}^3\text{He} \rightarrow (\pi^- \Lambda p) + p$ reaction

consistent with $K^- + {}^3\text{He} \rightarrow \Lambda p n$ reaction
branch seems to be order bigger

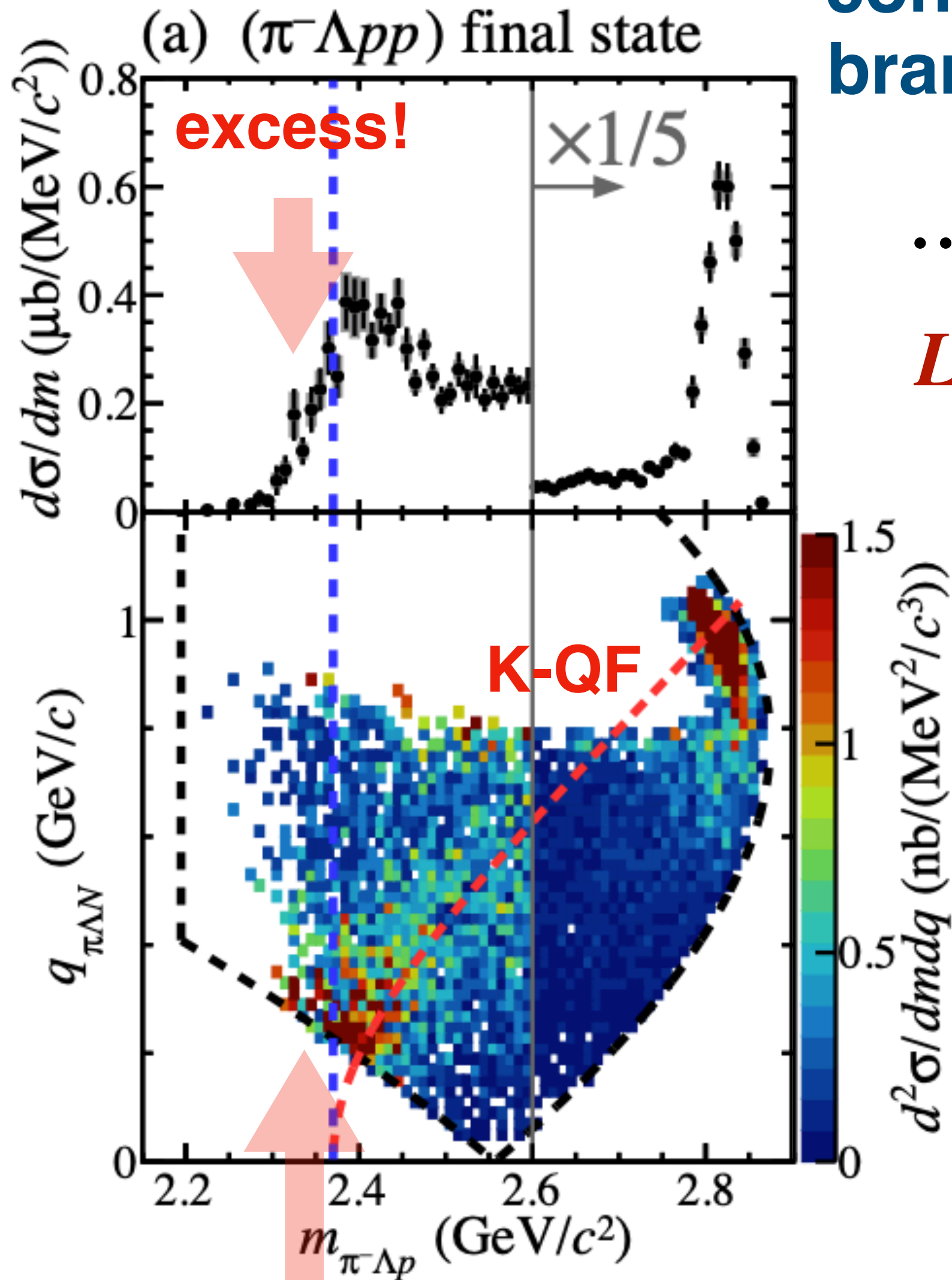
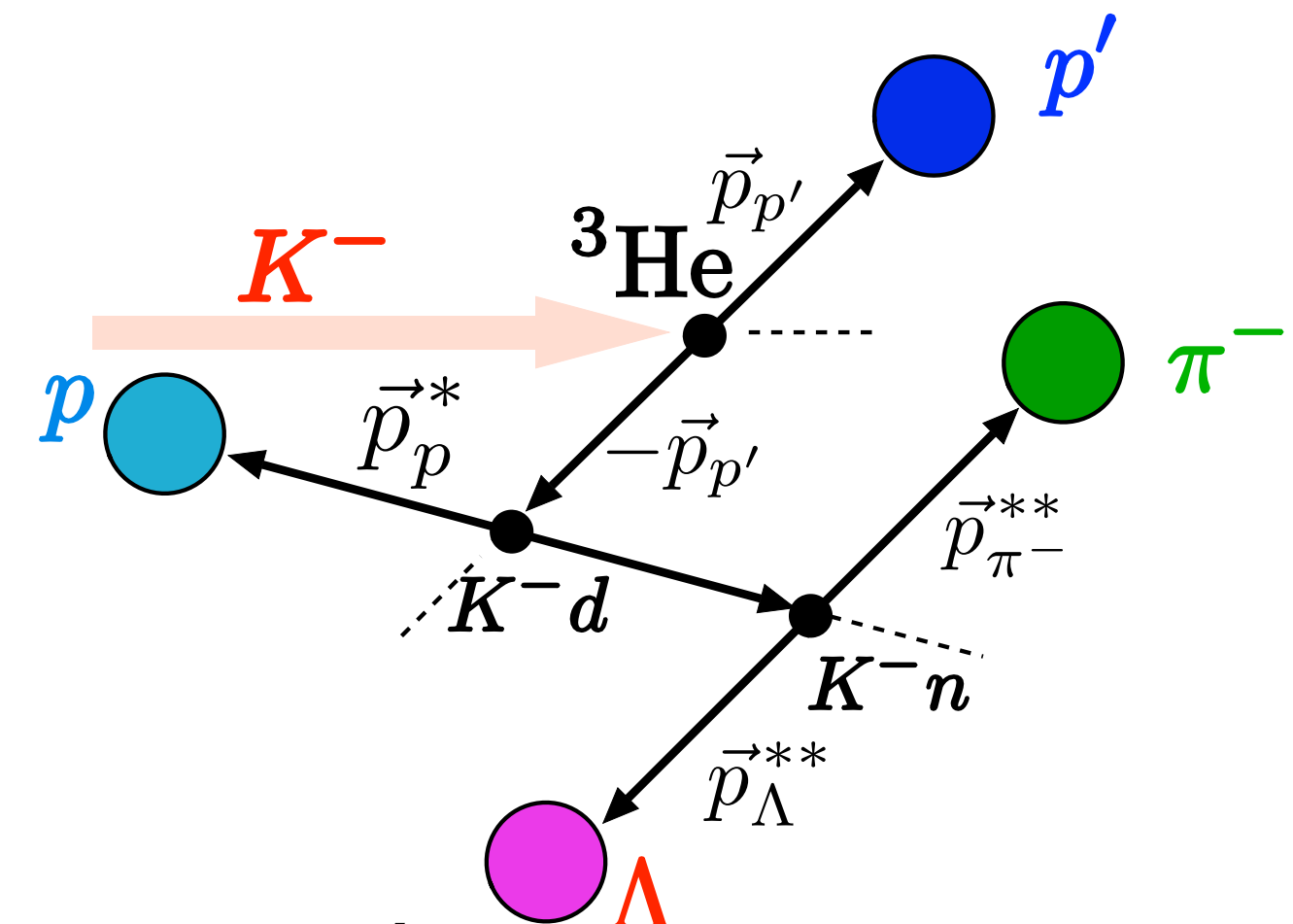

... *excess* is not easy to see ...

Let's normalize event density by 4-body phase space

The normalization by 4-body phase space, i.e., final-state-density

$$\rho_{(\pi^- \Lambda p p')} = \frac{d^2 N_{(\pi^- \Lambda p p')}}{dm_{\{\pi^- \Lambda p\}} dm_{\{\pi^- \Lambda\}}}$$

$$\propto p_{p'} \times p_p^* \times p_{\Lambda}^{**}$$

... analyzed by T. Yamaga

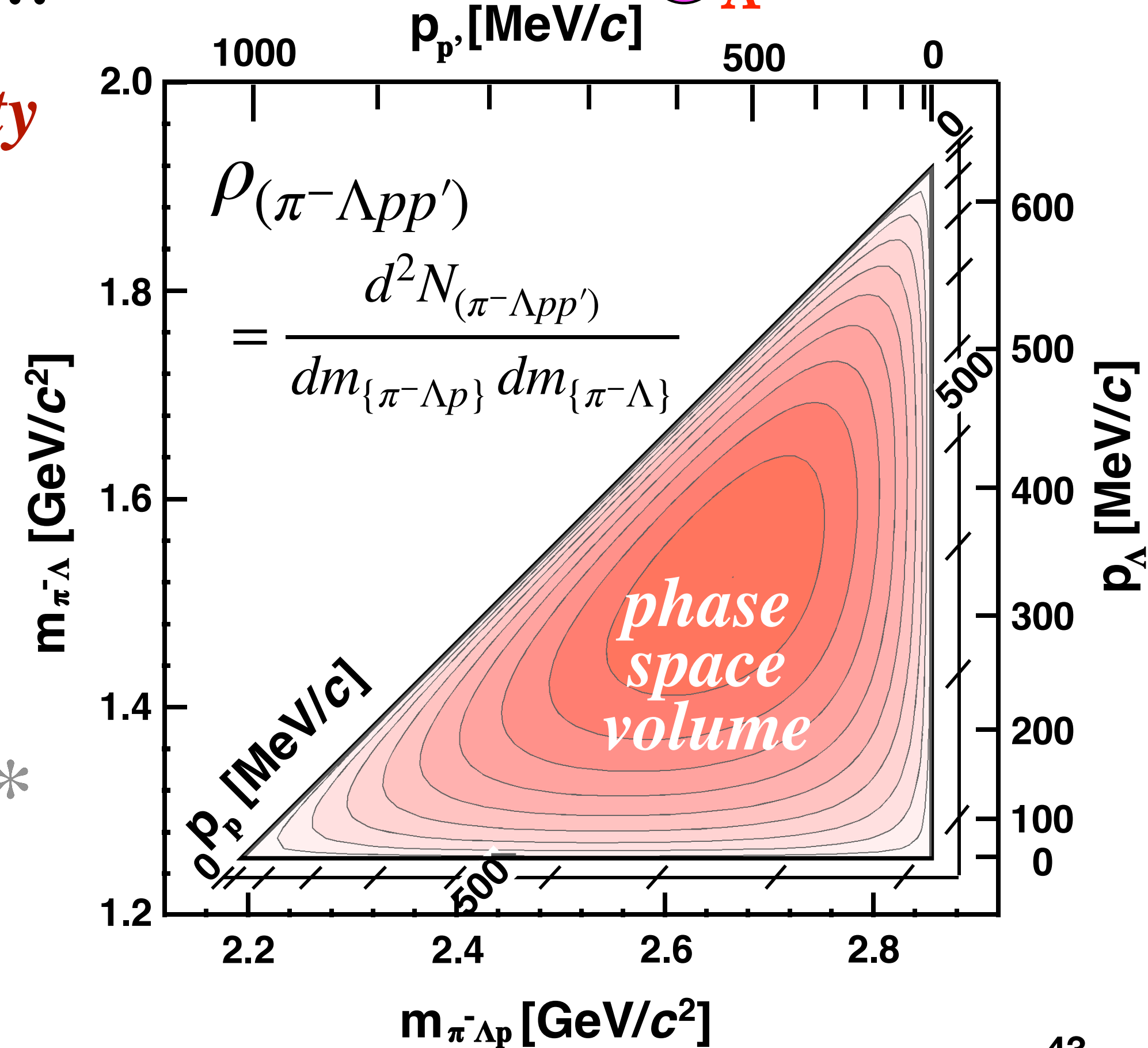

excess!

$K^- + {}^3\text{He} \rightarrow (\pi^- \Lambda p) + p$ reaction

consistent with $K^- + {}^3\text{He} \rightarrow \Lambda p n$ reaction
branch seems to be order bigger

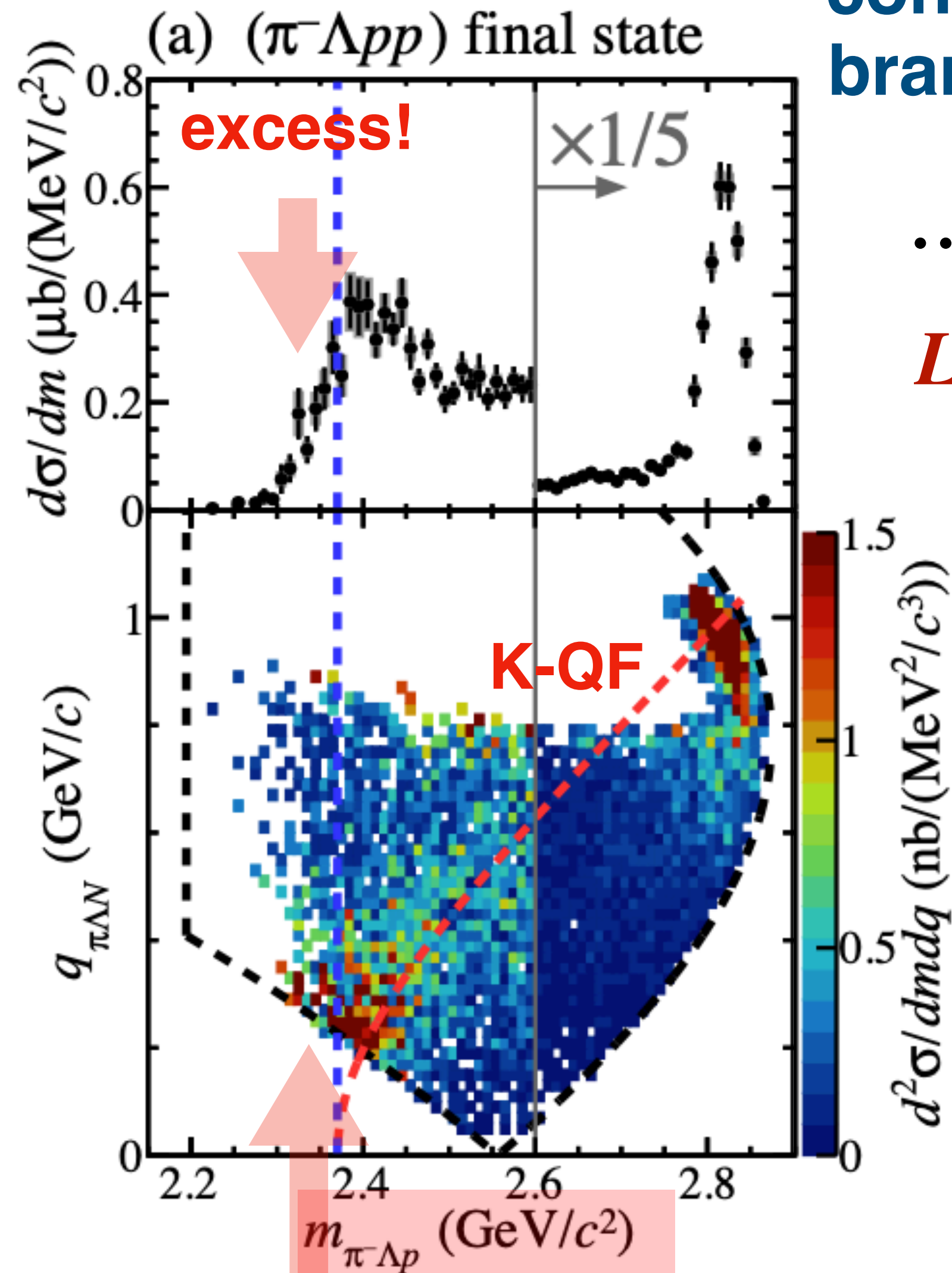

... *excess* is not easy to see ...

*Let's normalize event density
by 4-body phase space*

*The normalization by 4-body
phase space, i.e., final-state-
density*

$$\rho_{(\pi^- \Lambda p p')} = \frac{d^2 N_{(\pi^- \Lambda p p')}}{dm_{\{\pi^- \Lambda p\}} dm_{\{\pi^- \Lambda\}}}$$

$$\propto p_{p'} \times p_p^* \times p_\Lambda^{**}$$

... analyzed by T. Yamaga

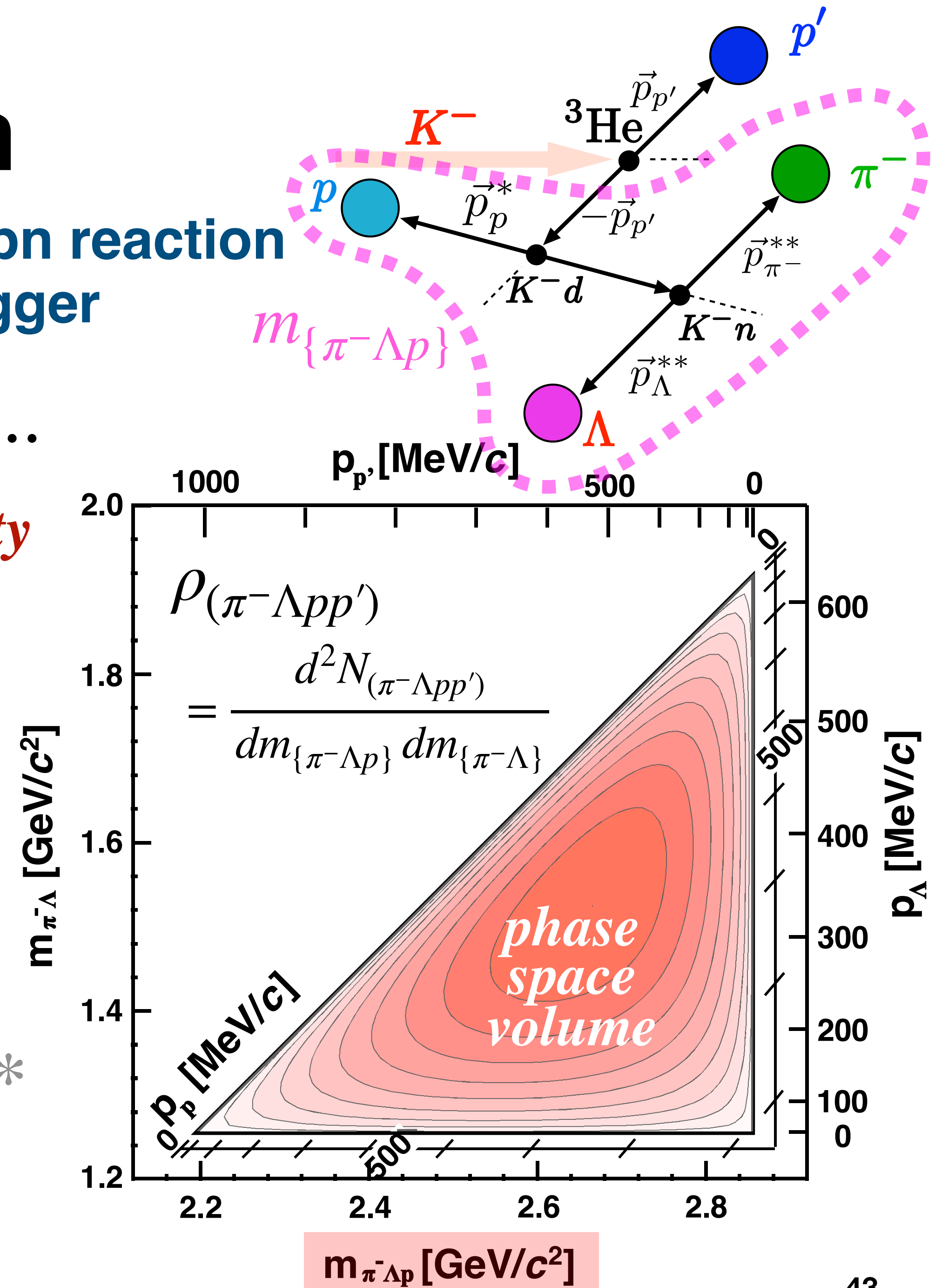

$K^- + {}^3\text{He} \rightarrow (\pi^- \Lambda p) + p$ reaction

consistent with $K^- + {}^3\text{He} \rightarrow \Lambda p n$ reaction
branch seems to be order bigger

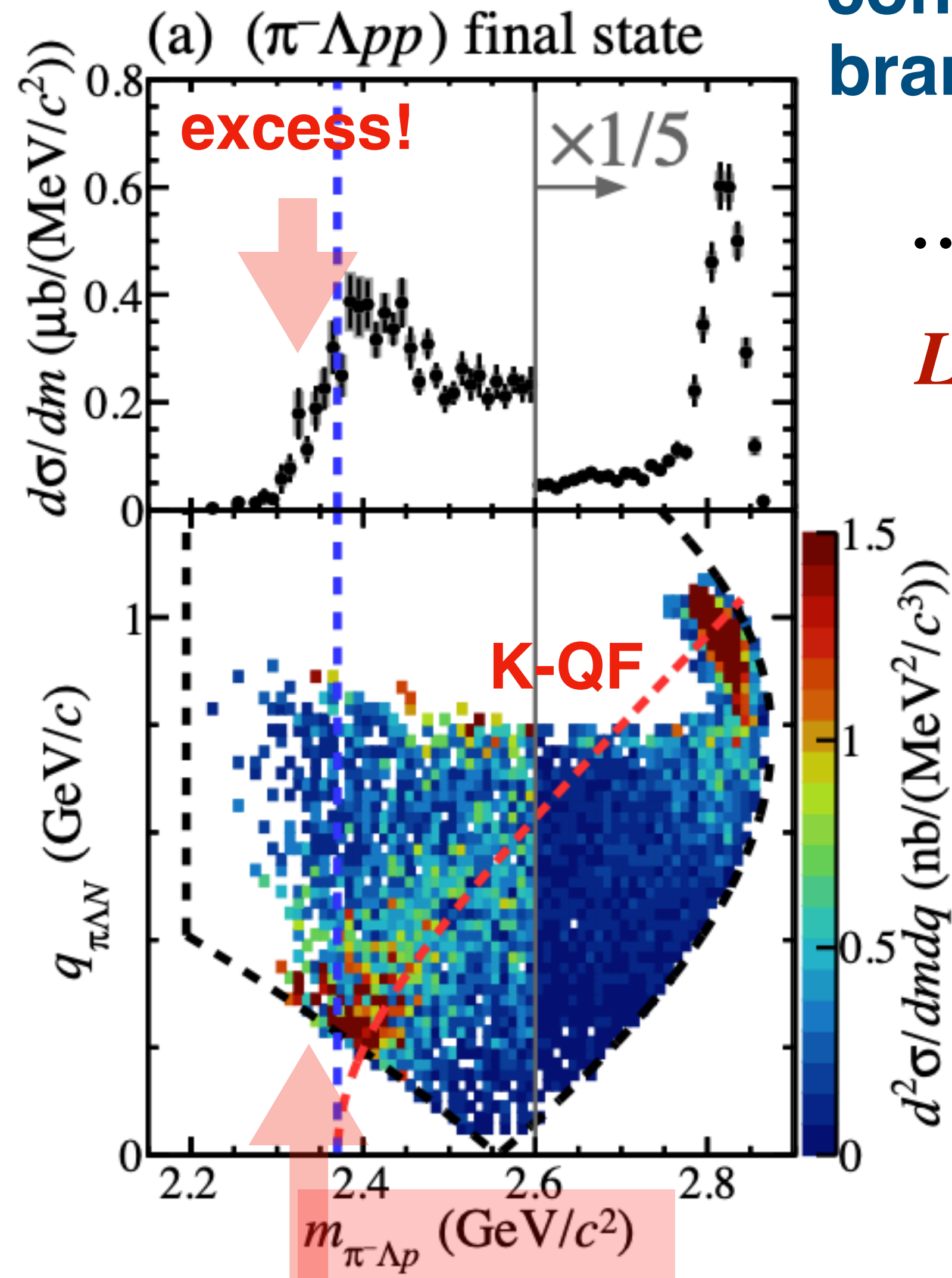

... *excess* is not easy to see ...

Let's normalize event density by 4-body phase space

The normalization by 4-body phase space, i.e., final-state-density

$$\rho_{(\pi^- \Lambda p p')} = \frac{d^2 N_{(\pi^- \Lambda p p')}}{dm_{\{\pi^- \Lambda p\}} dm_{\{\pi^- \Lambda\}}}$$

$$\propto p_{p'} \times p_p^* \times p_\Lambda^{**}$$

... analyzed by T. Yamaga

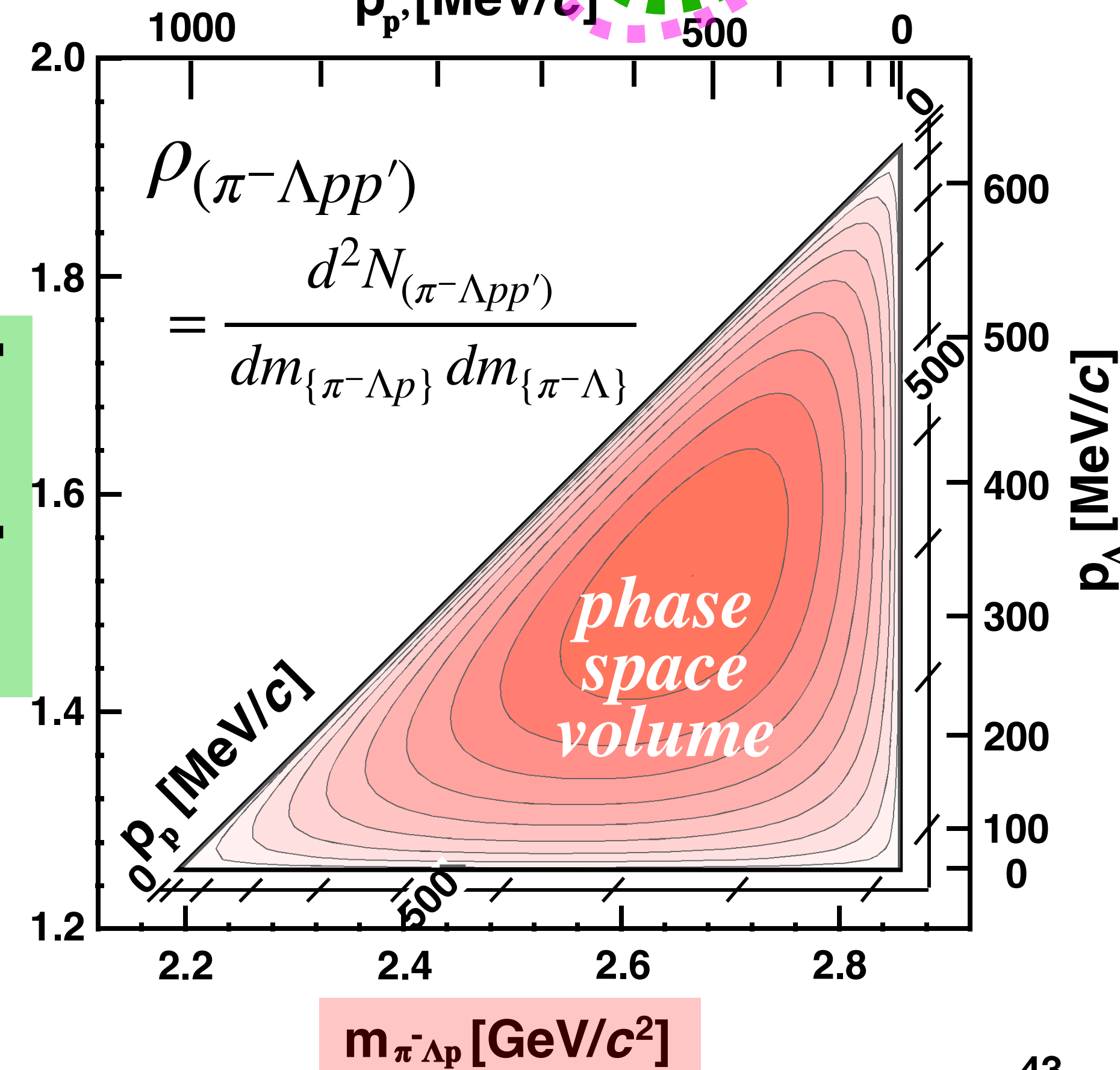
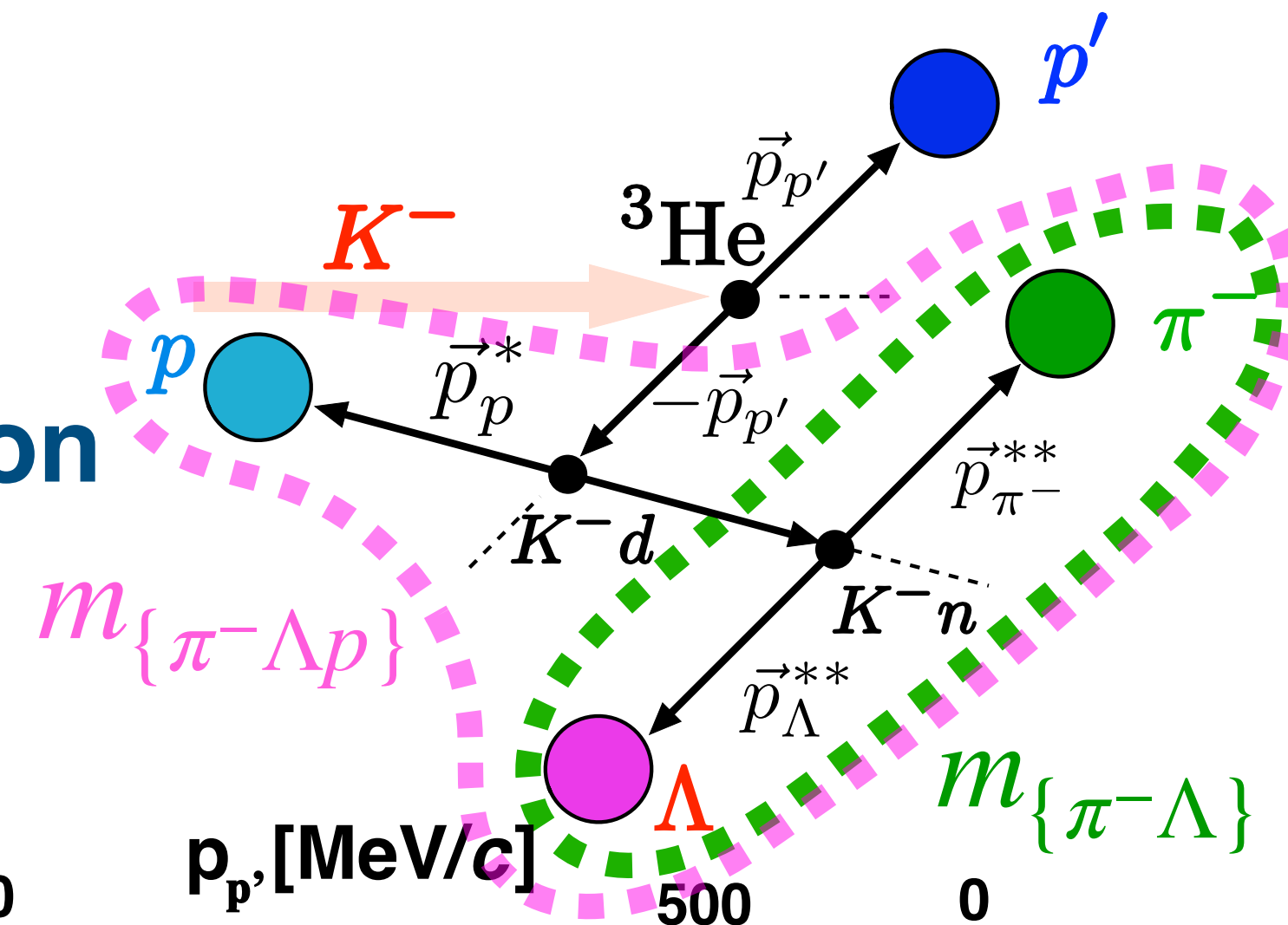

excess!

$K^- + {}^3\text{He} \rightarrow (\pi^- \Lambda p) + p$ reaction

consistent with $K^- + {}^3\text{He} \rightarrow \Lambda p n$ reaction
branch seems to be order bigger

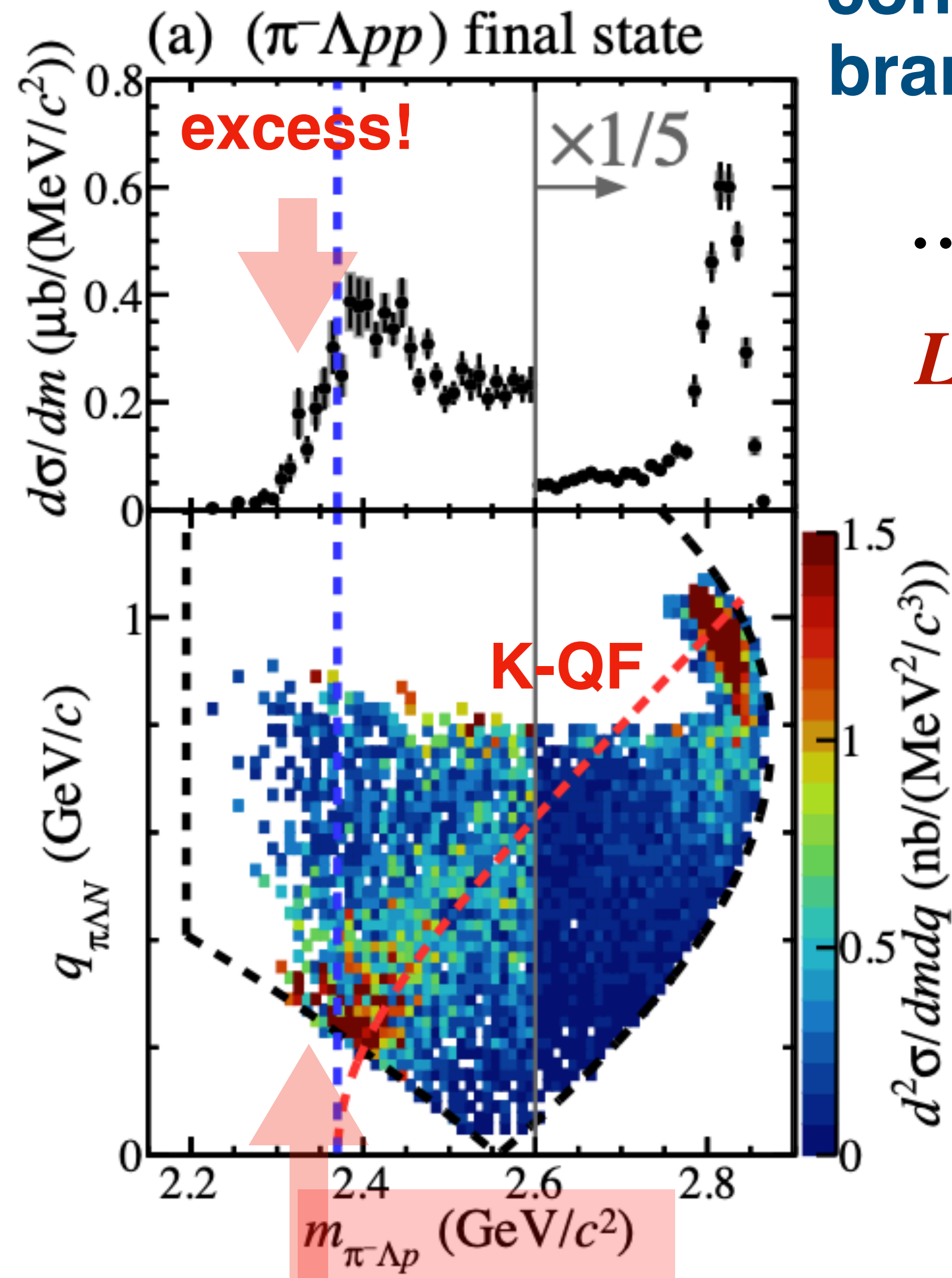

... *excess* is not easy to see ...

Let's normalize event density by 4-body phase space

The normalization by 4-body phase space, i.e., final-state-density

$$\rho_{(\pi^- \Lambda p p')} = \frac{d^2 N_{(\pi^- \Lambda p p')}}{dm_{\{\pi^- \Lambda p\}} dm_{\{\pi^- \Lambda\}}}$$

$$\propto p_{p'} \times p_p^* \times p_\Lambda^{**}$$

... analyzed by T. Yamaga

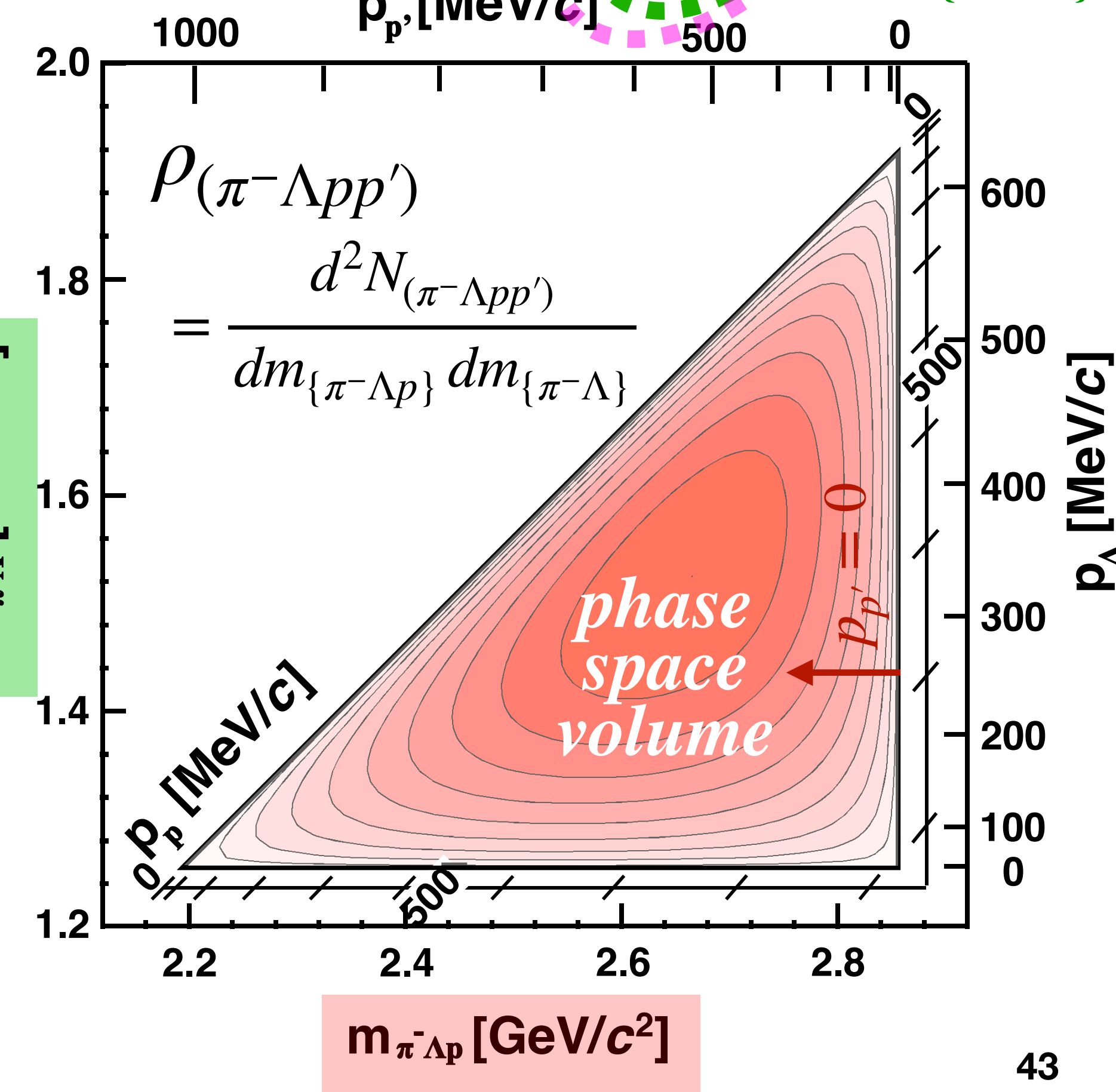
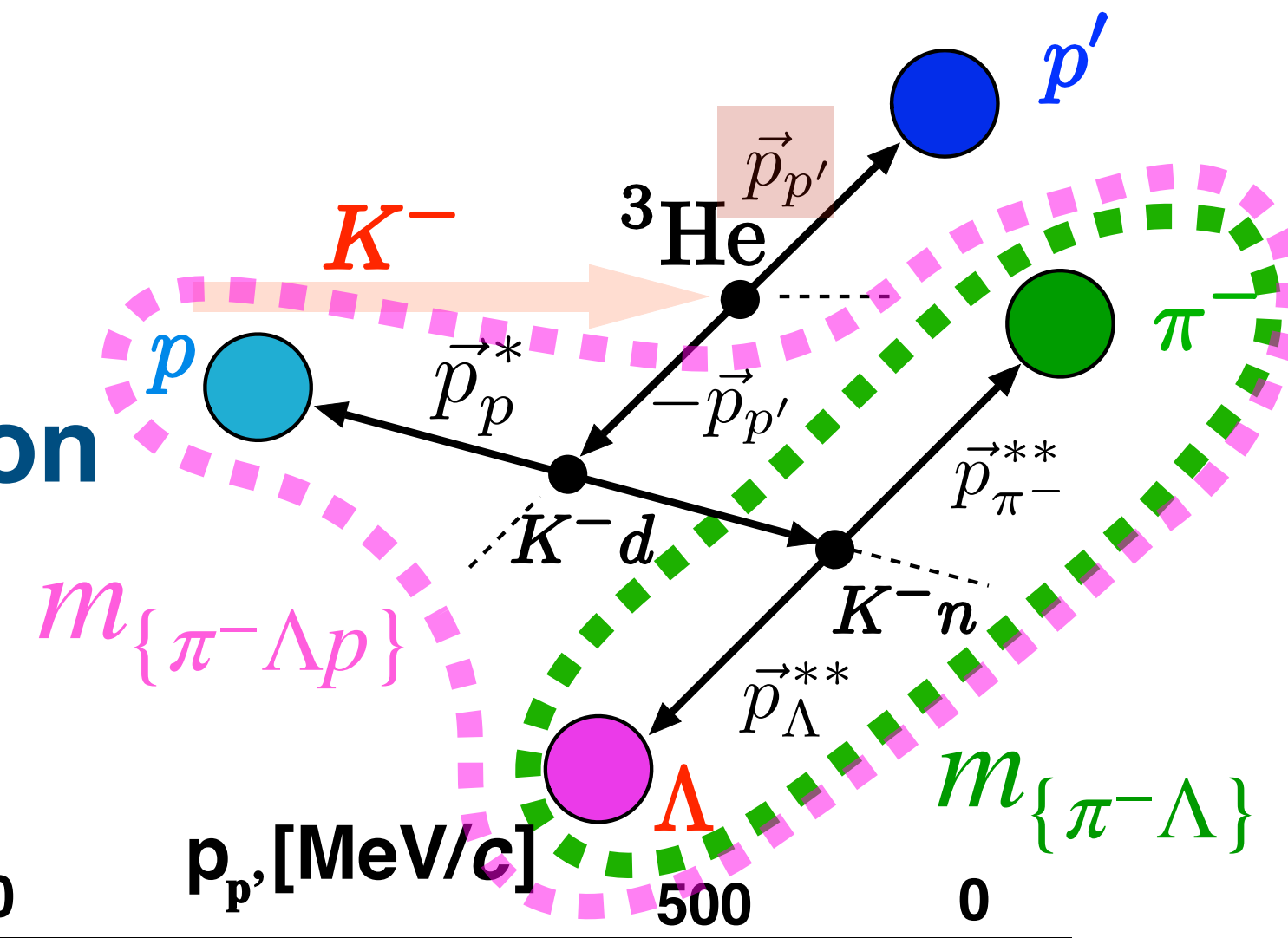

$K^- + {}^3\text{He} \rightarrow (\pi^- \Lambda p) + p$ reaction

consistent with $K^- + {}^3\text{He} \rightarrow \Lambda p n$ reaction
branch seems to be order bigger

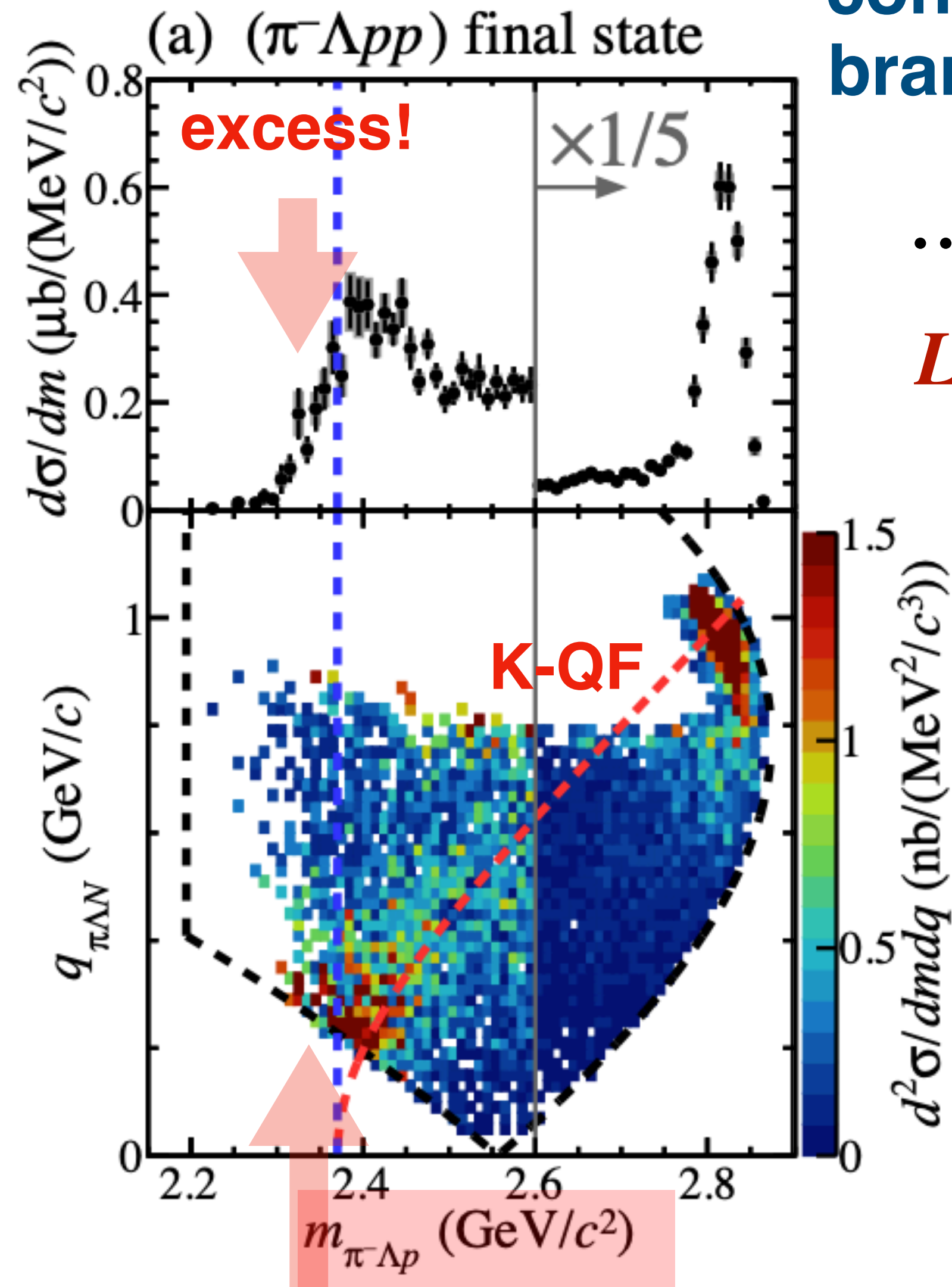

... *excess* is not easy to see ...

Let's normalize event density by 4-body phase space

The normalization by 4-body phase space, i.e., final-state-density

$$\rho_{(\pi^- \Lambda p p')} = \frac{d^2 N_{(\pi^- \Lambda p p')}}{dm_{\{\pi^- \Lambda p\}} dm_{\{\pi^- \Lambda\}}}$$

$$\propto p_{p'} \times p_p^* \times p_\Lambda^{**}$$

... analyzed by T. Yamaga

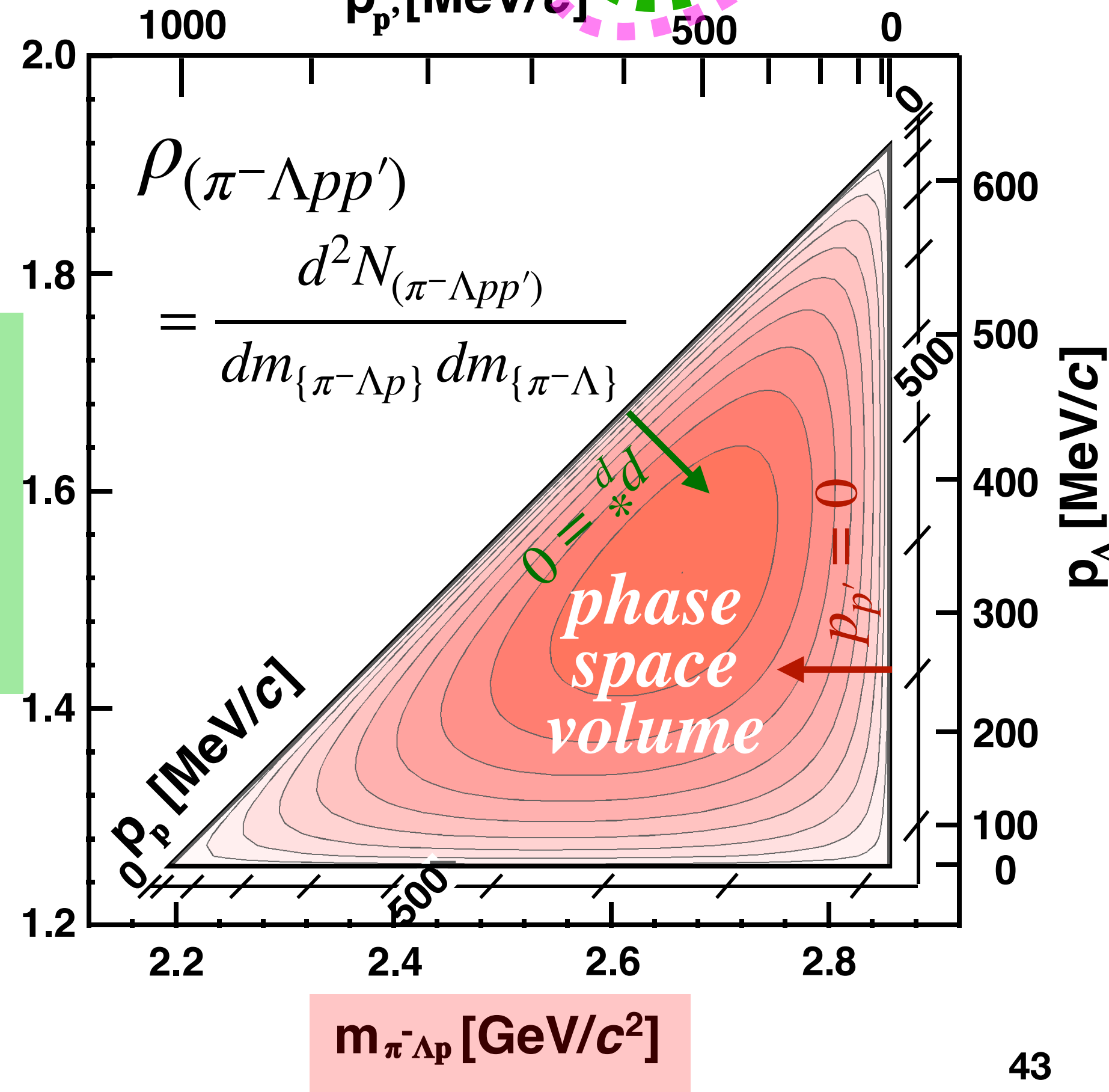
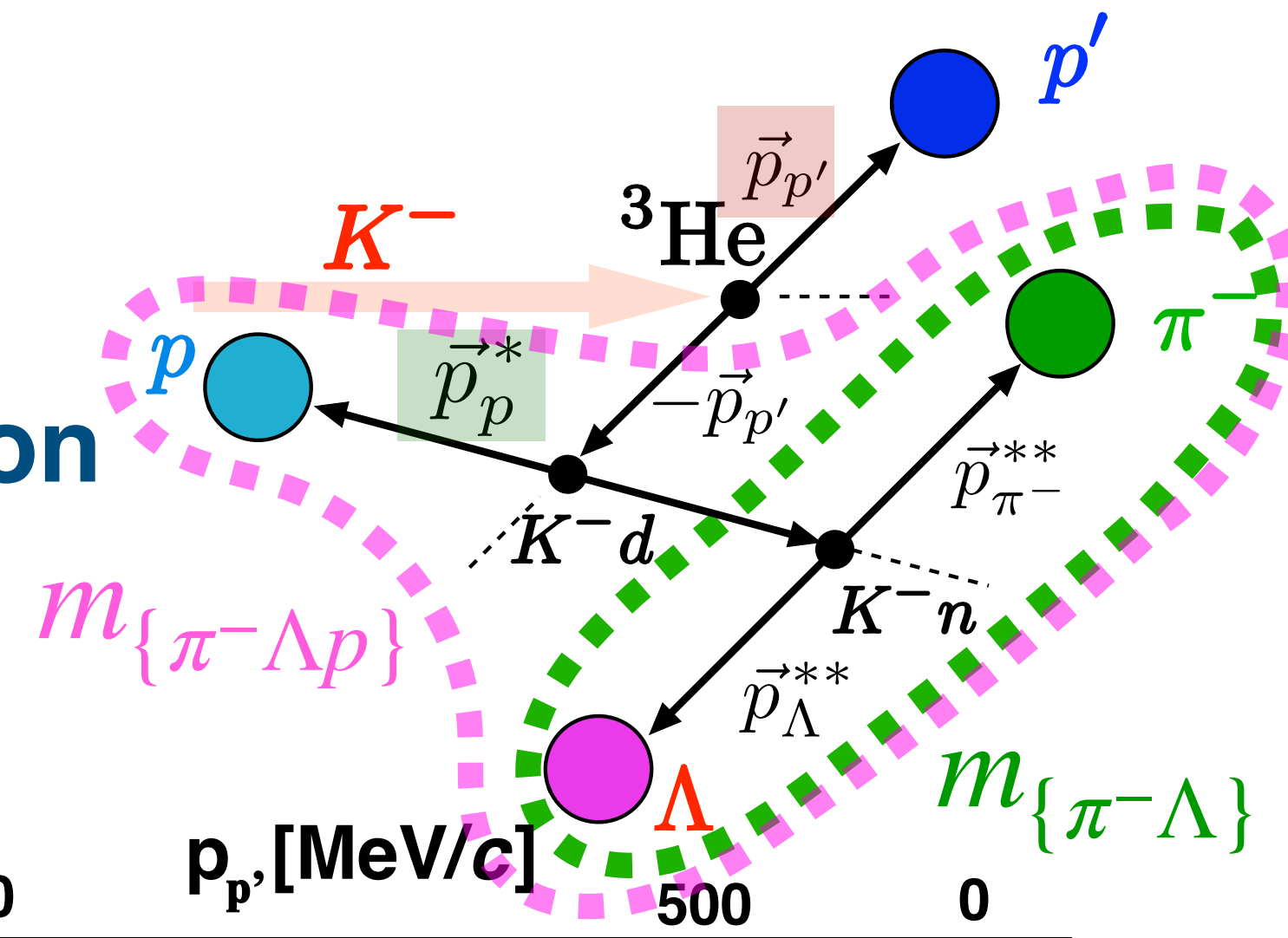

$K^- + {}^3\text{He} \rightarrow (\pi^- \Lambda p) + p$ reaction

consistent with $K^- + {}^3\text{He} \rightarrow \Lambda p n$ reaction
branch seems to be order bigger

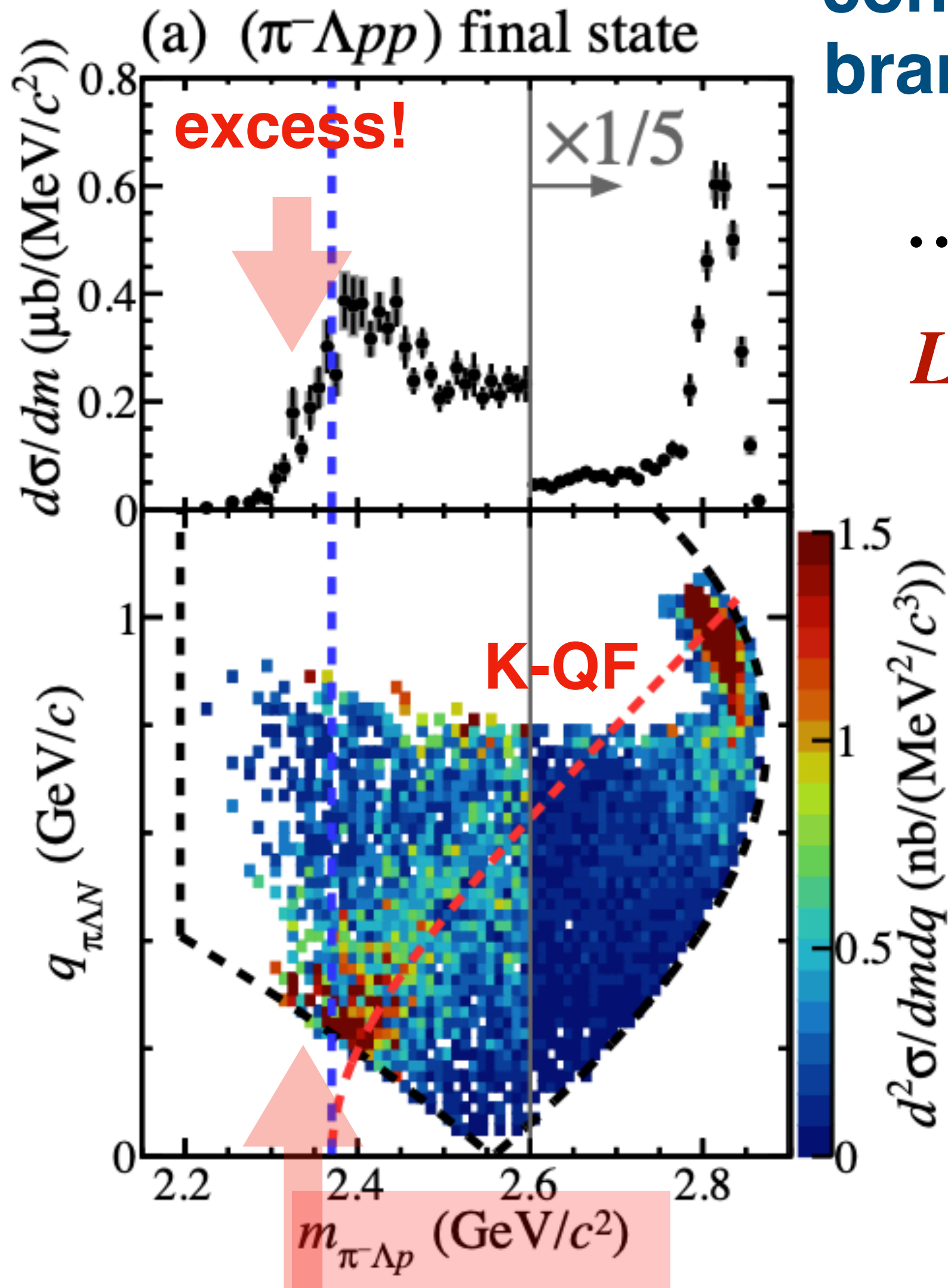

... *excess* is not easy to see ...

Let's normalize event density by 4-body phase space

The normalization by 4-body phase space, i.e., final-state-density

$$\rho_{(\pi^- \Lambda p p')} = \frac{d^2 N_{(\pi^- \Lambda p p')}}{dm_{\{\pi^- \Lambda p\}} dm_{\{\pi^- \Lambda\}}}$$

$$\propto p_{p'} \times p_p^* \times p_\Lambda^{**}$$

... analyzed by T. Yamaga

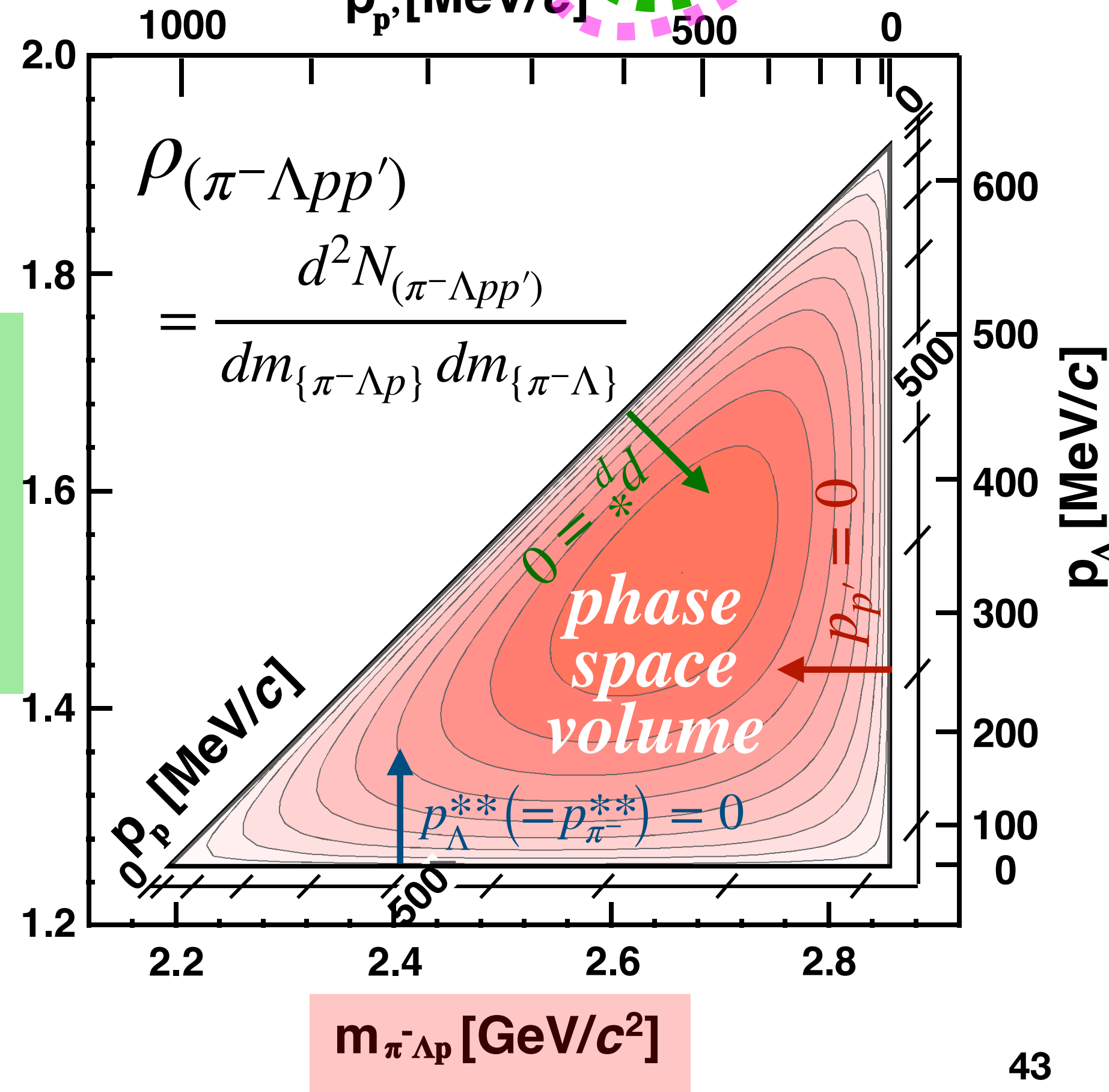
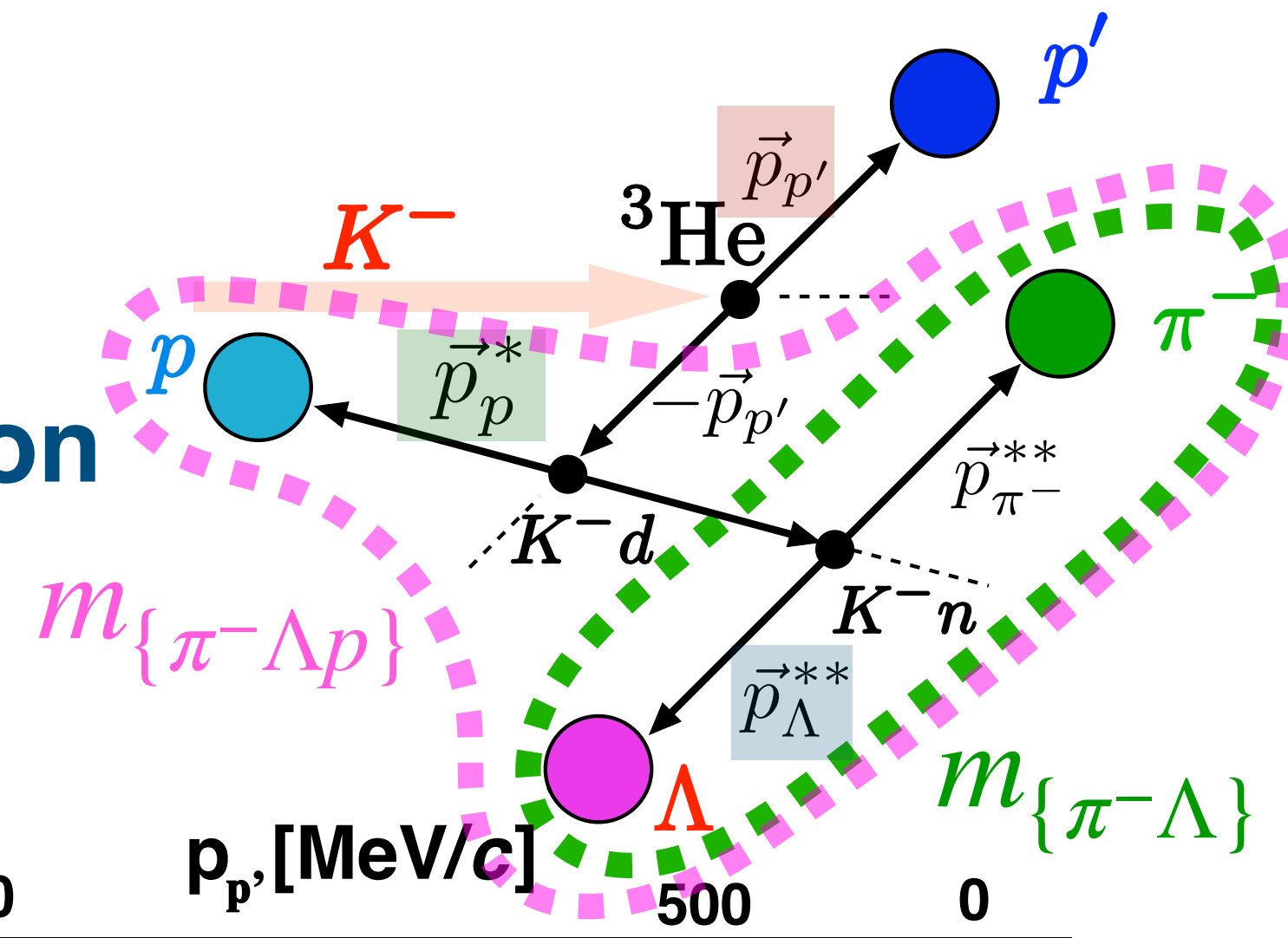

“ K^-pp ”鏡像核“ \bar{K}^0nn ”の存在?

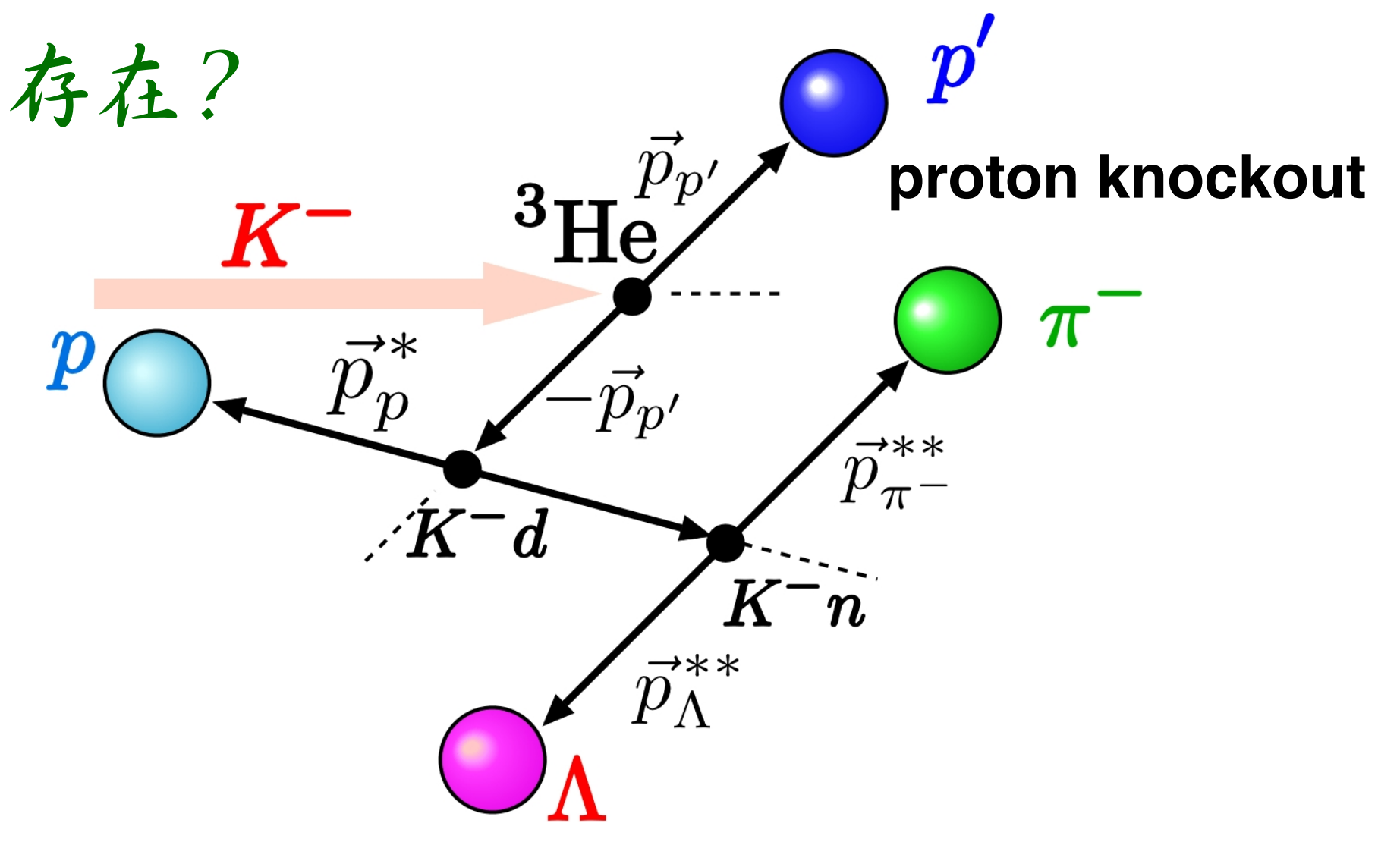
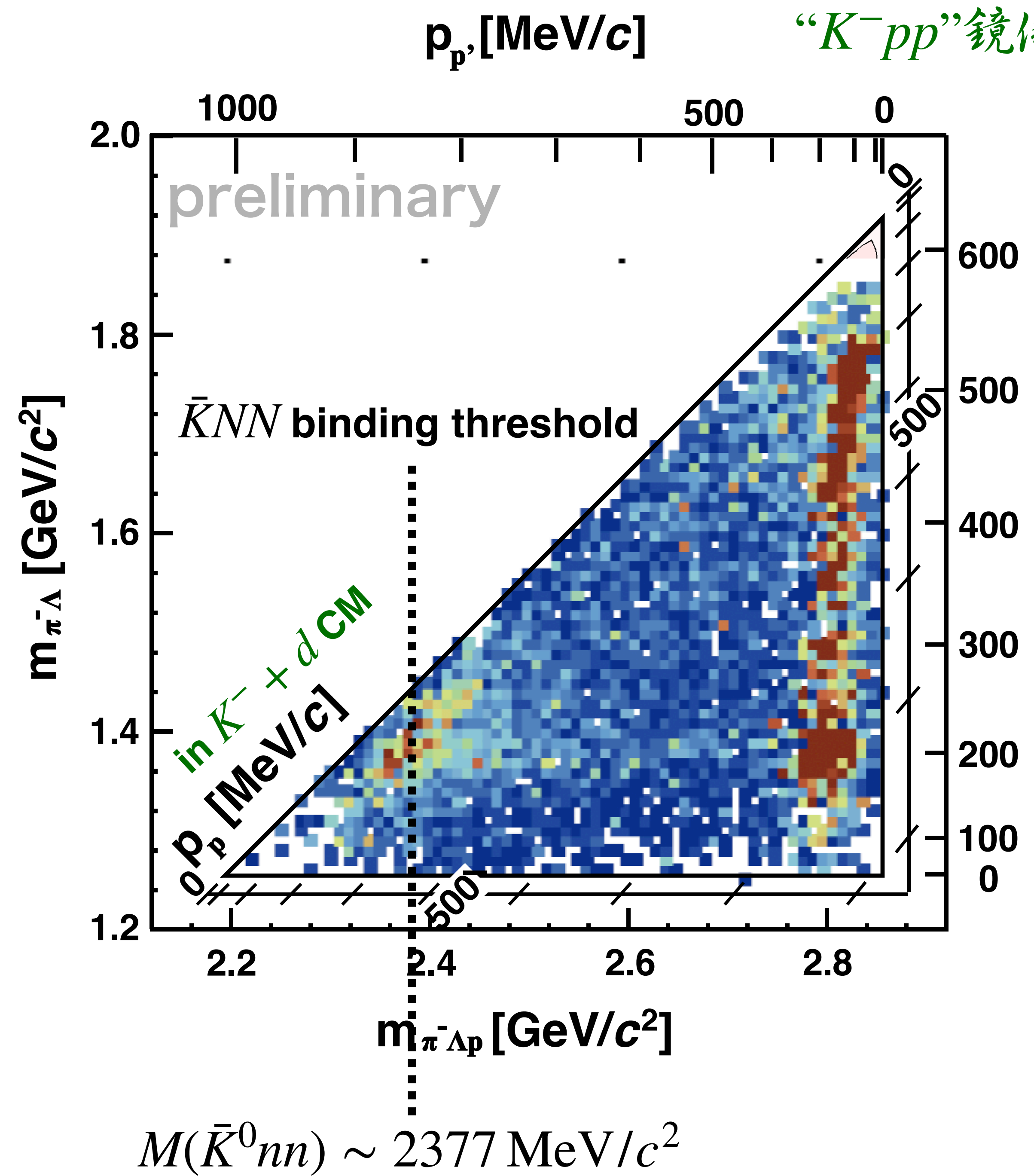

“ K^-pp ”鏡像核“ \bar{K}^0nn ”の存在?

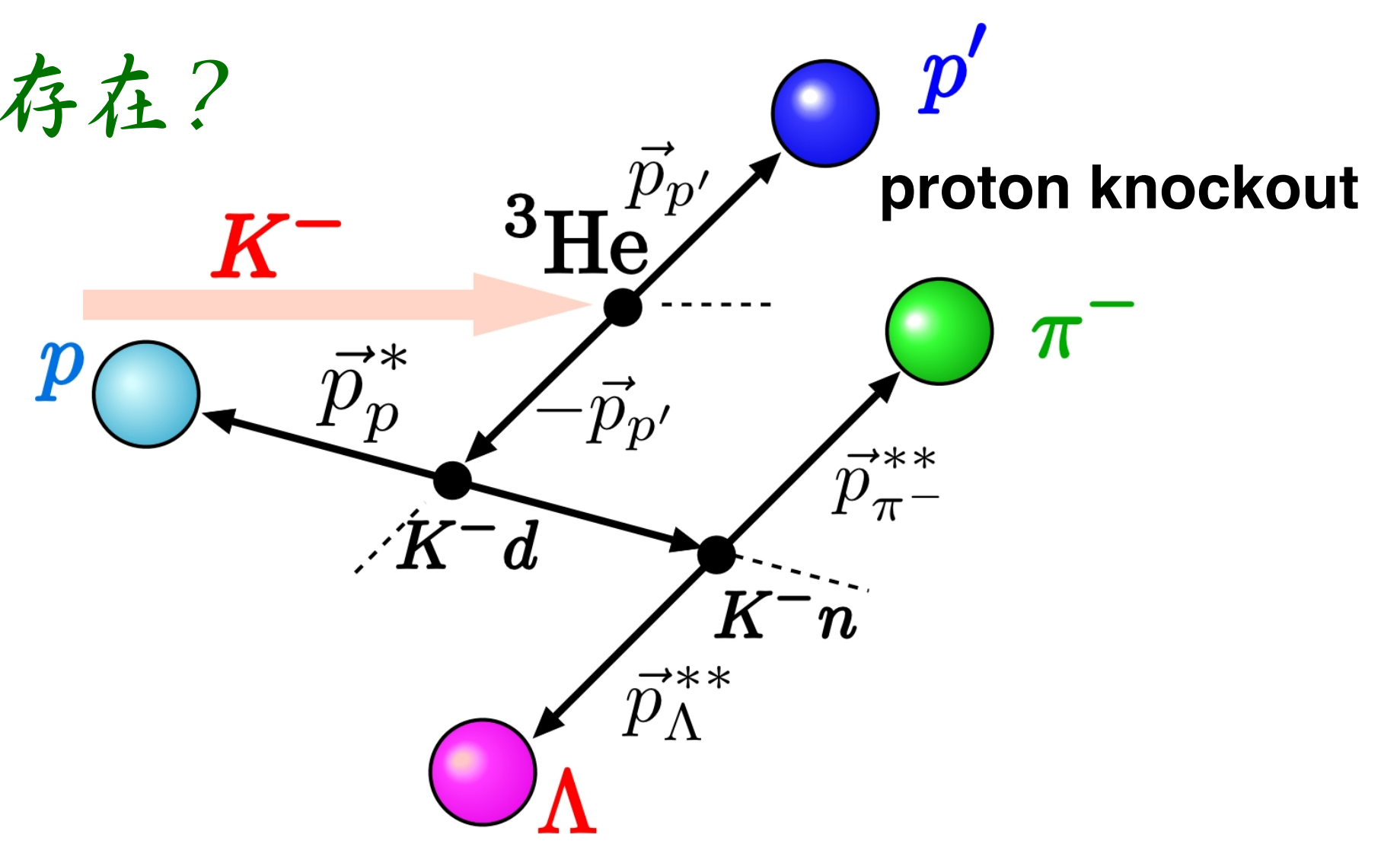
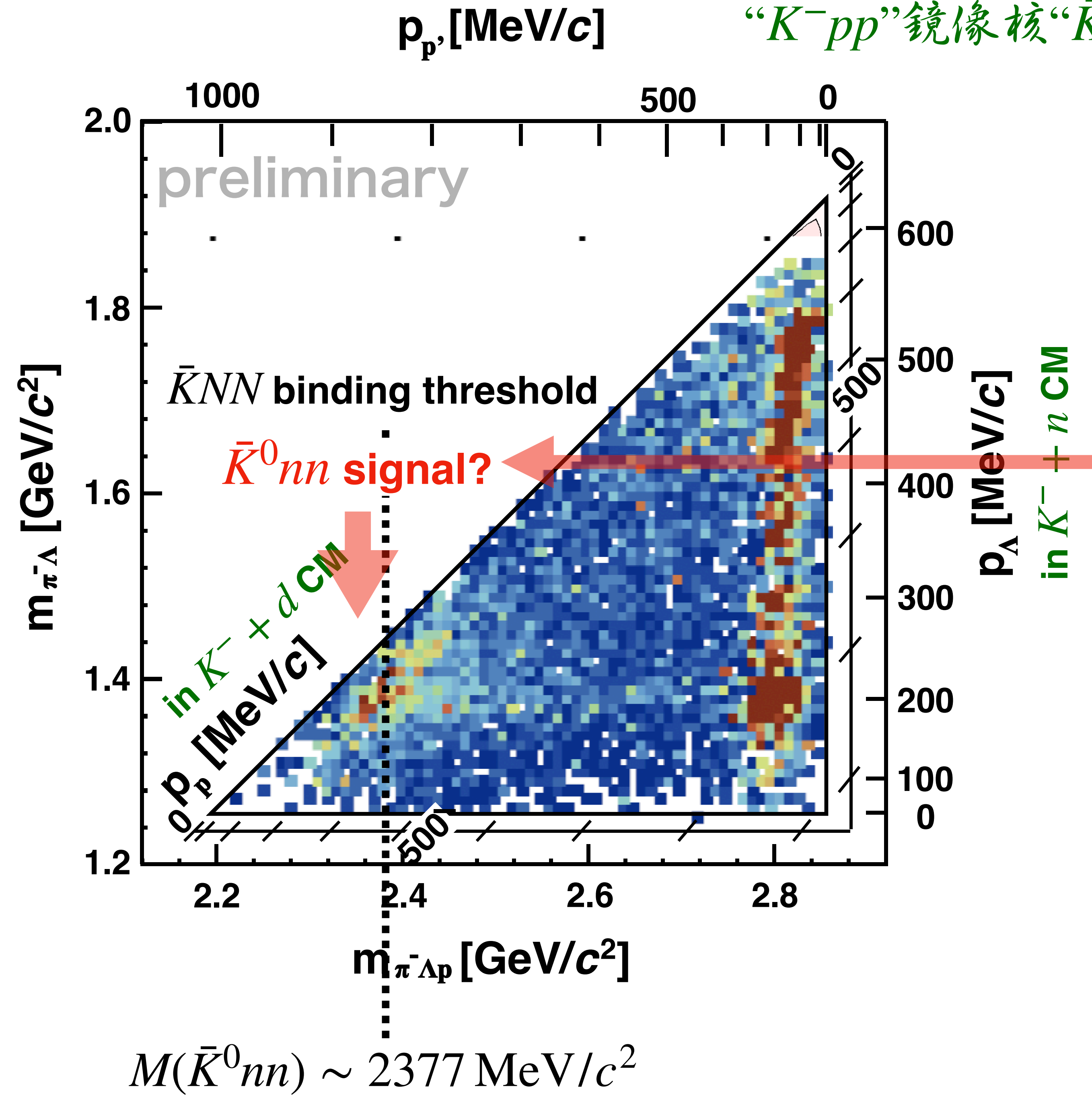

$\bar{K}^0 nn$ signal-like event concentration below \bar{K} -bound threshold is seen?
 — twice more data become available in April —

“ K^-pp ”鏡像核“ \bar{K}^0nn ”の存在?

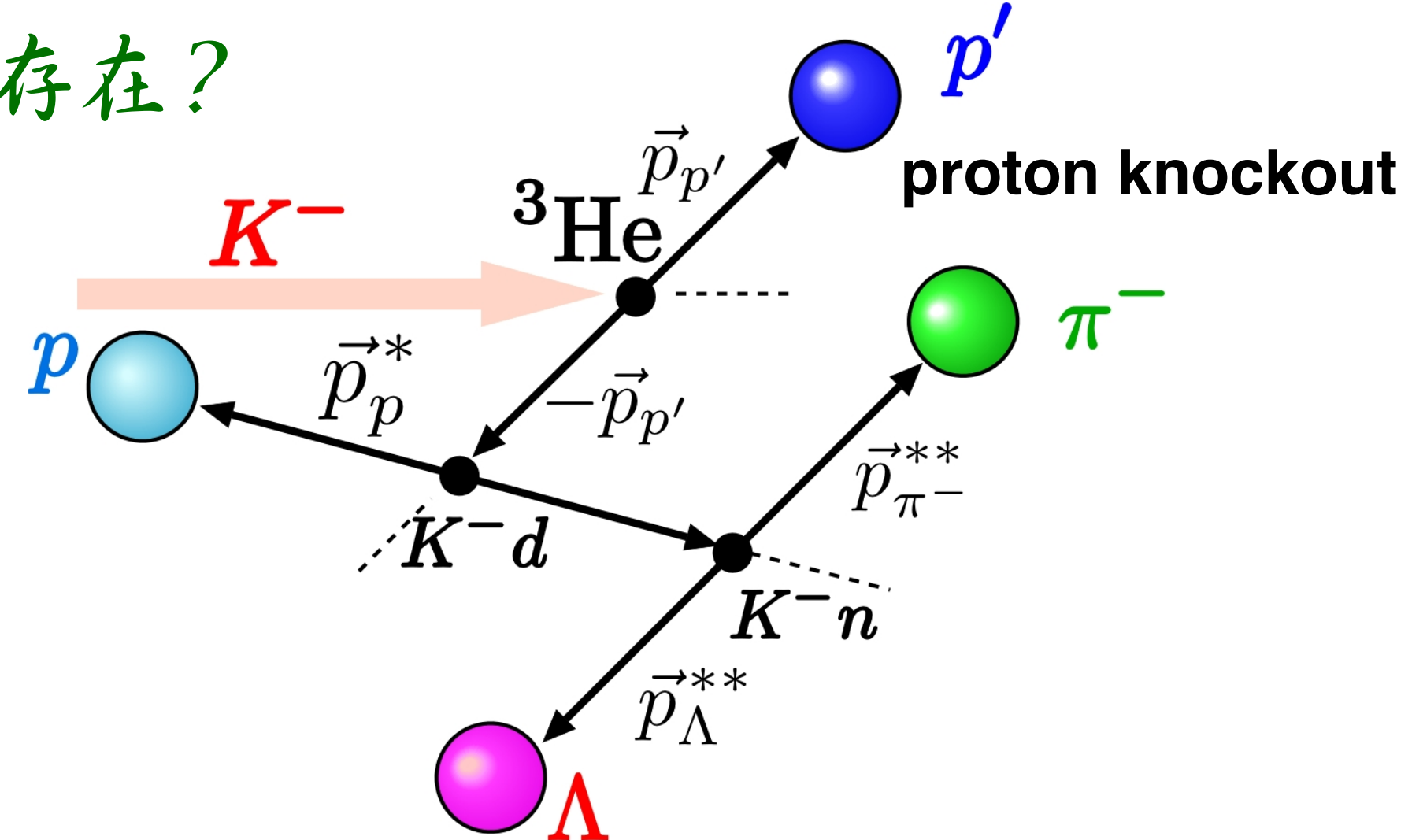
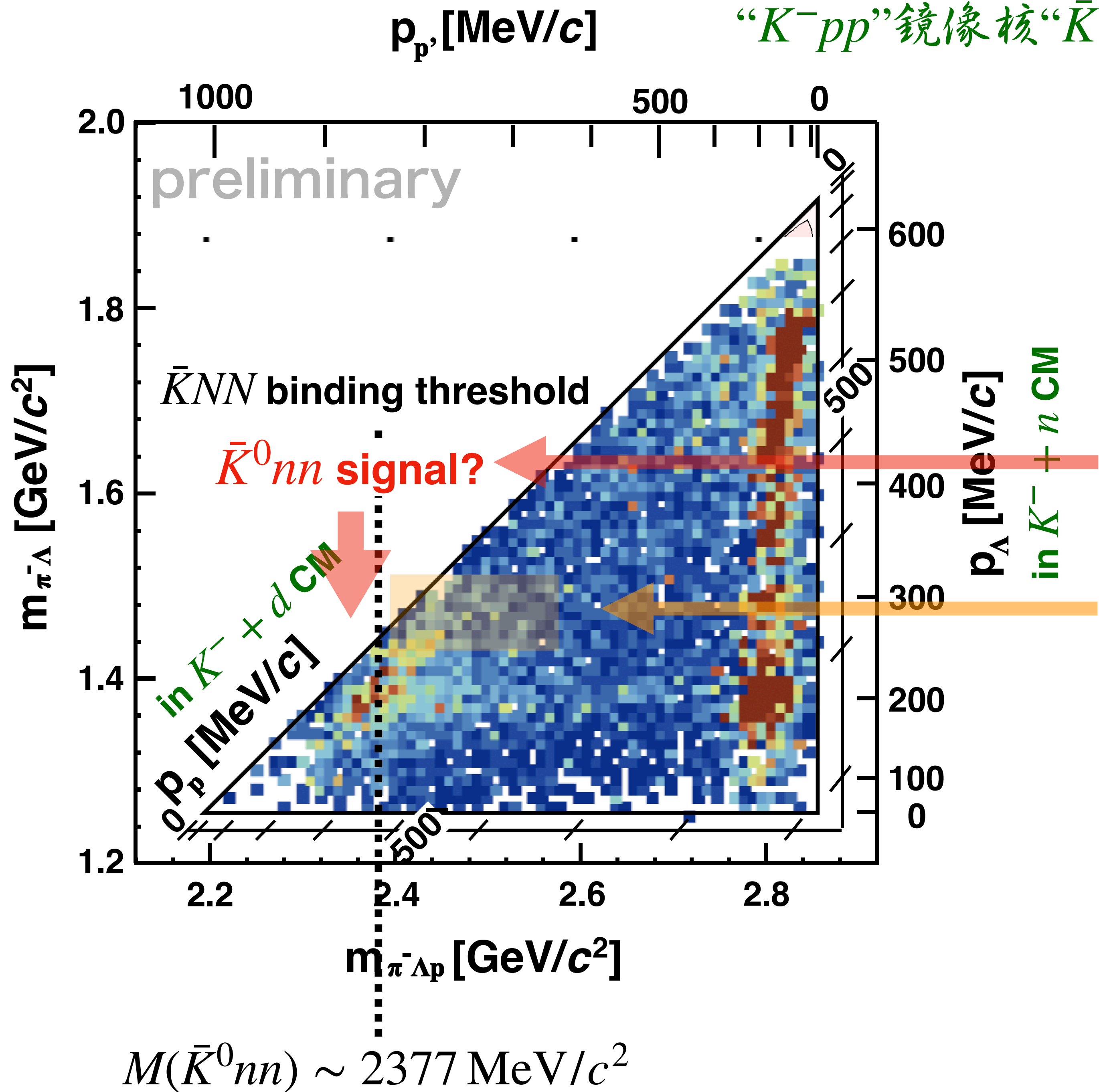

$\bar{K}^0 nn$ signal-like event concentration below \bar{K} -bound threshold is seen?
 — twice more data become available in April —
 QF-K induced reaction?

“ K^-pp ”鏡像核“ \bar{K}^0nn ”の存在?

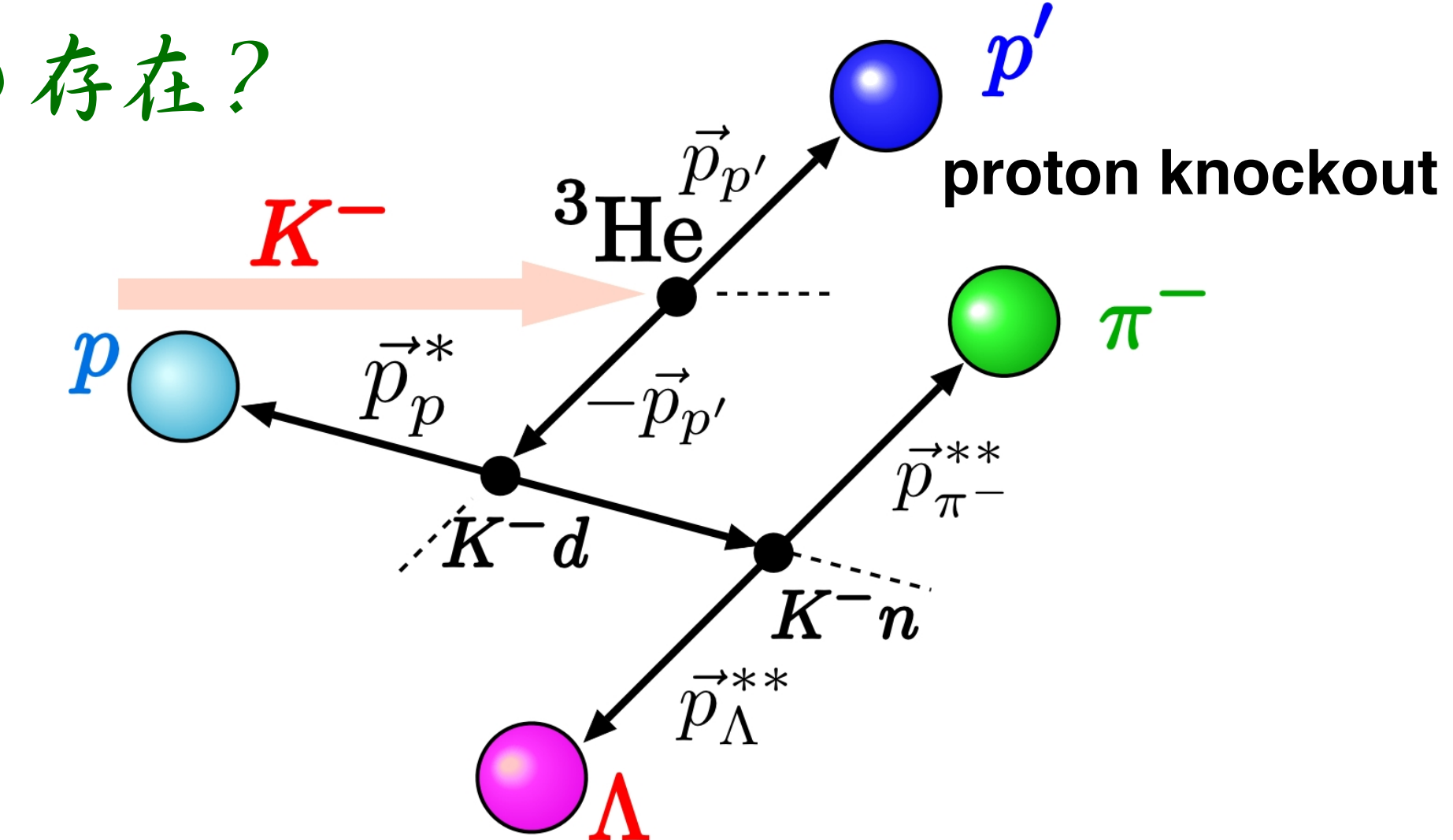
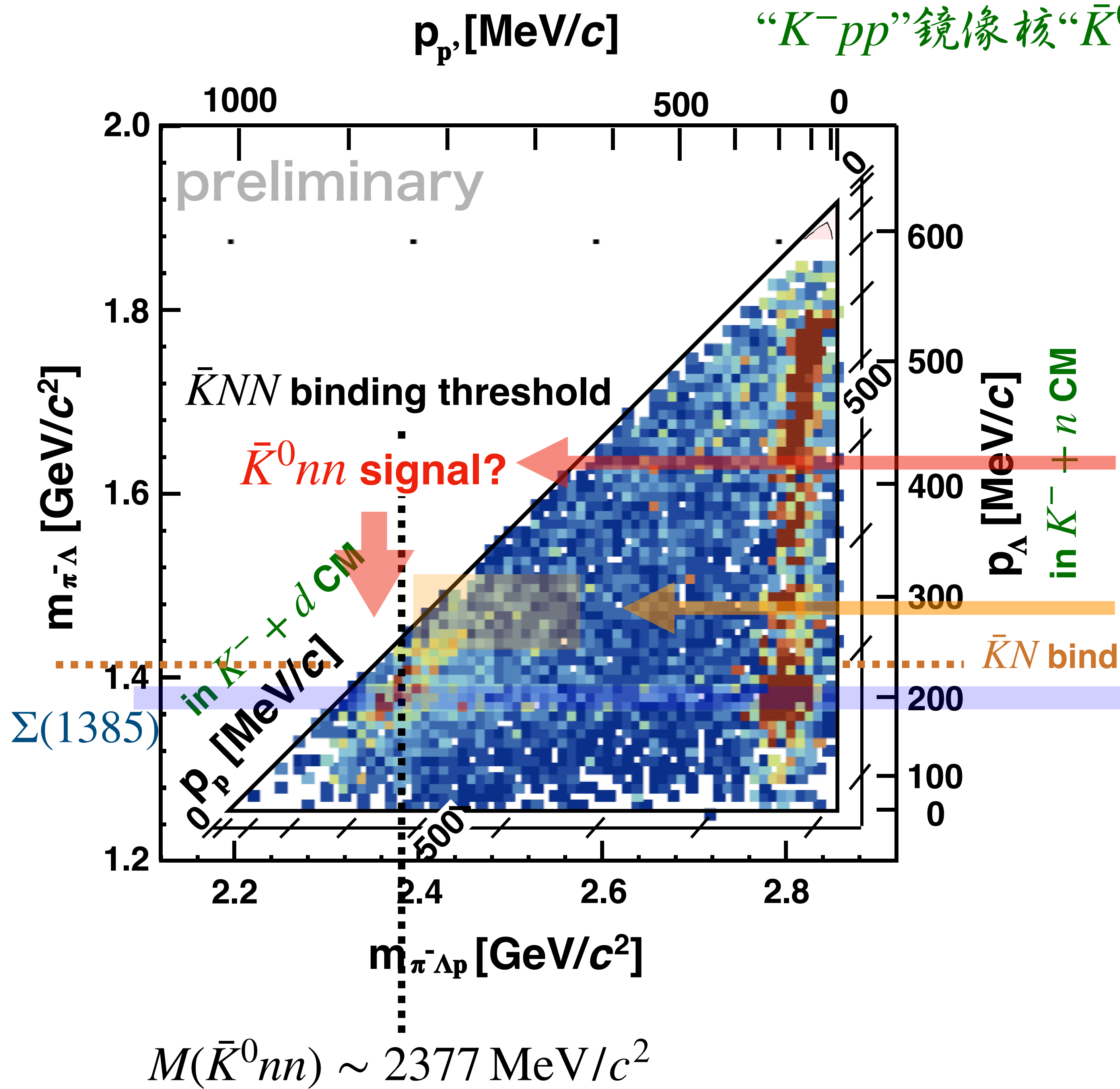

$\bar{K}^0 nn$ signal-like event concentration below \bar{K} -bound threshold is seen?
 — twice more data become available in April —

QF-K induced reaction?

$\bar{K}N$ binding threshold

$\Sigma(1385)$ contribution is not negligible compared to $(\Lambda p) + n$ final state.

“ K^-pp ”鏡像核“ \bar{K}^0nn ”の存在?

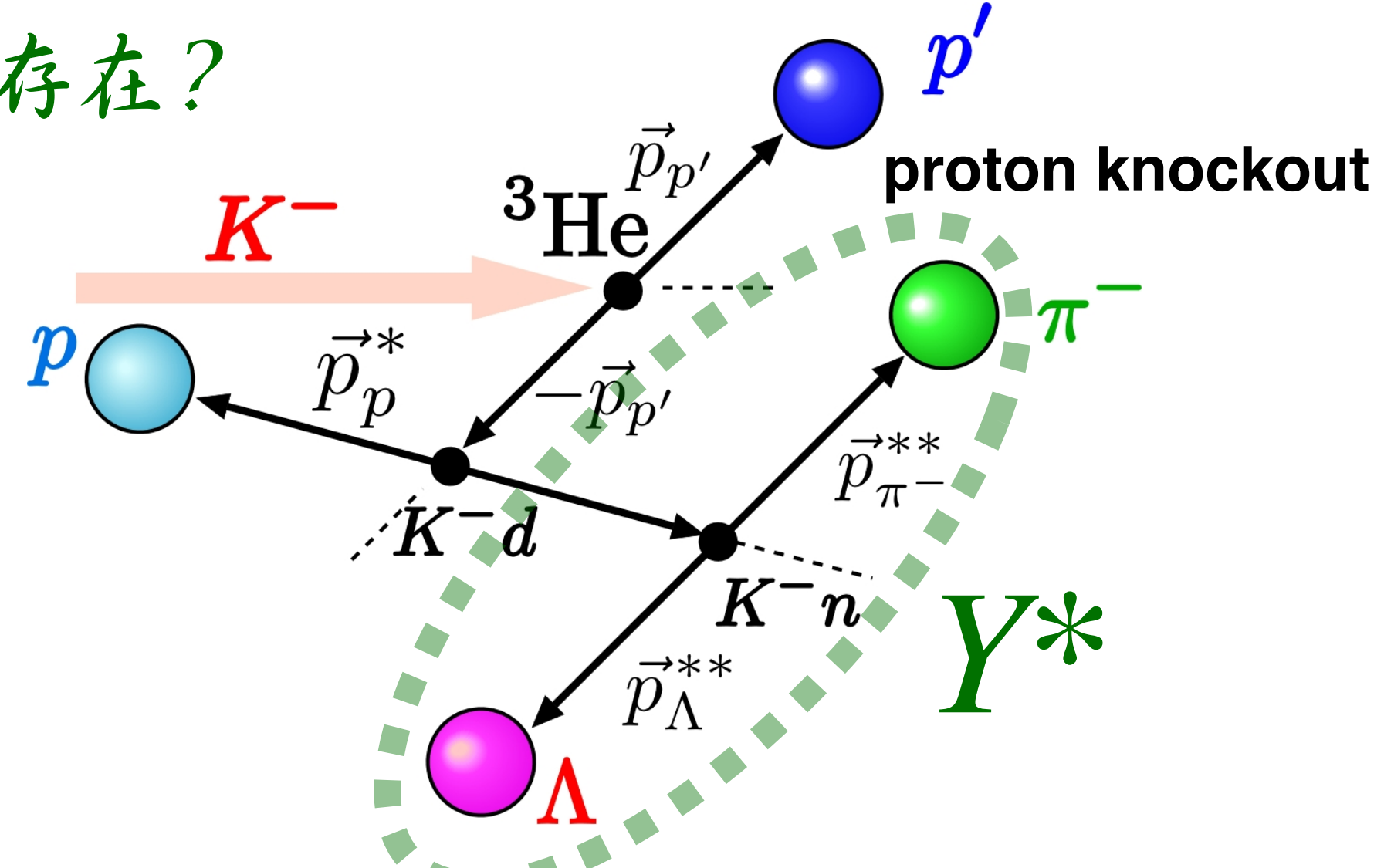
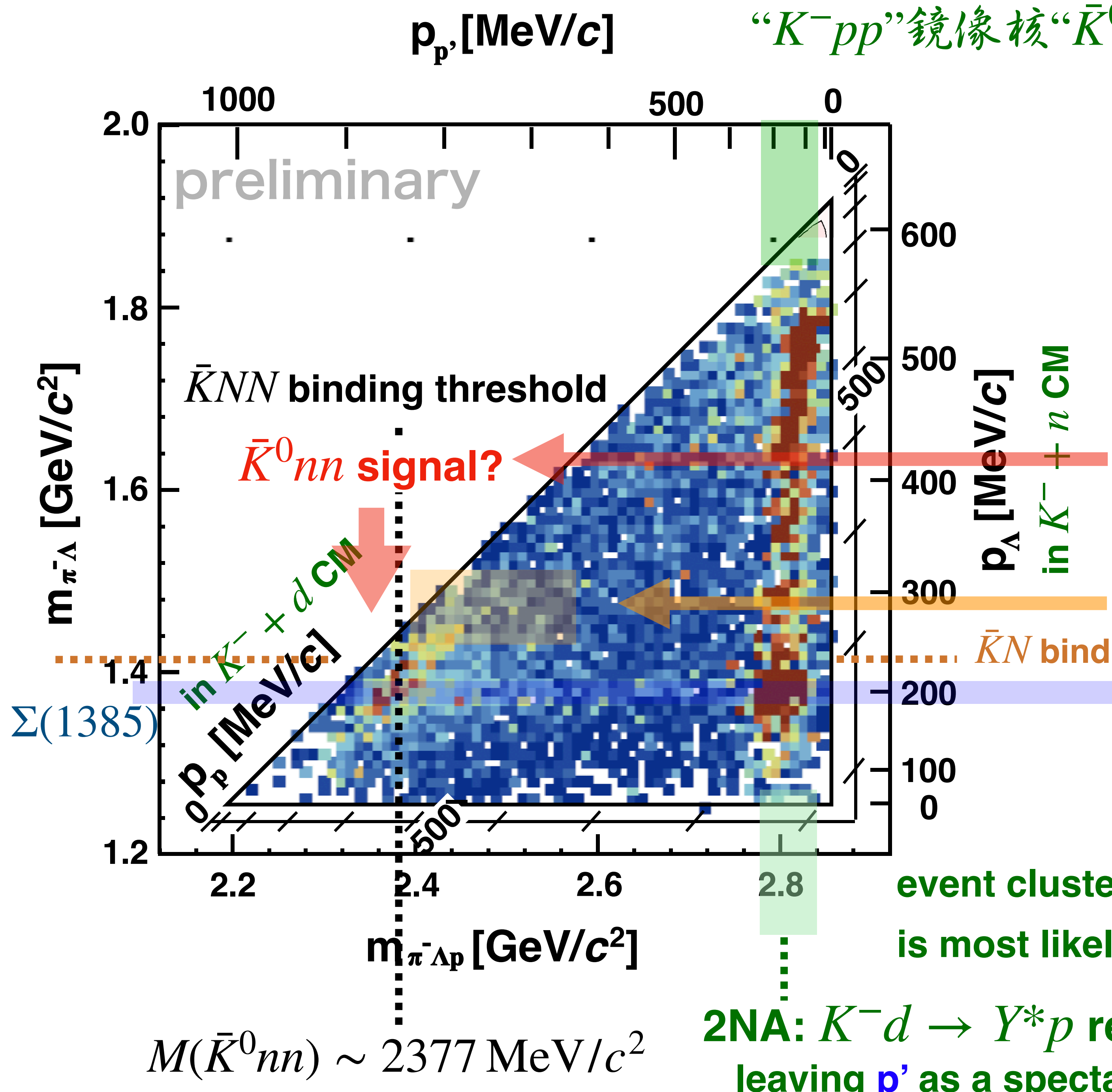

\bar{K}^0nn signal-like event concentration below \bar{K} -bound threshold is seen?
 — twice more data become available in April —

QF-K induced reaction?
 $\Sigma(1385)$ contribution is not negligible compared to $(\Lambda p) + n$ final state.

event cluster at $m_{\pi-\Lambda p} \sim \sqrt{s_{K-d}} \approx 2.83 \text{ GeV}$

is most likely ... 核内クラスター構造の存在?

— K^- seems to be sensitive to the deuteron cluster in ${}^3\text{He}$ —

2NA: $K^-d \rightarrow Y^*p$ reaction leaving p' as a spectator

What we learned for kaonic nuclear bound state:

K束縛核についてわかったこと

- K^-pp $\left(I(J^P) = \frac{1}{2}(0^- \text{ or } 1^-?) \right)$ identified in $\bar{K}NN \rightarrow \Lambda p$ analysis (2N_{KA})

Phys. Lett. B789, 620-625 (2019)

Phys. Rev. C102, 044002 (2020)

“ K^-pp ” $\rightarrow \Lambda p$ decay requires
the isospin to be $I_{\bar{K}NN} = 1/2$.

- $\bar{K}NN \rightarrow \pi Y p$ decay dominance (1N_{KA} \gg 2N_{KA}) $Br_{\pi Y p} > 10 \times Br_{\Lambda p}$

- K^-pp isospin partner, \bar{K}^0nn , would be identified in $\pi^- \Lambda p$ decay

$\bar{K}N$ interaction is also strong in $I_{\bar{K}N} = 1$, at least for absorption

<https://arxiv.org/abs/2404.01773> ... T. Yamaga



- $\bar{K}NNN$ $\left(I(J^P) = 0 \left(\frac{1}{2}^- \right) \right)$ identified in $K^-ppn \rightarrow \Lambda d$ *one more data available in April*
Spin-Parity automatically FIXED!

Preliminary analysis \rightarrow Three nucleon bound state!

Higher statistics is needed to be conclusive... T. Hashimoto

Budget Profile and Objective of the Project

予算の現状分析と
今後の研究計画

Budget profile

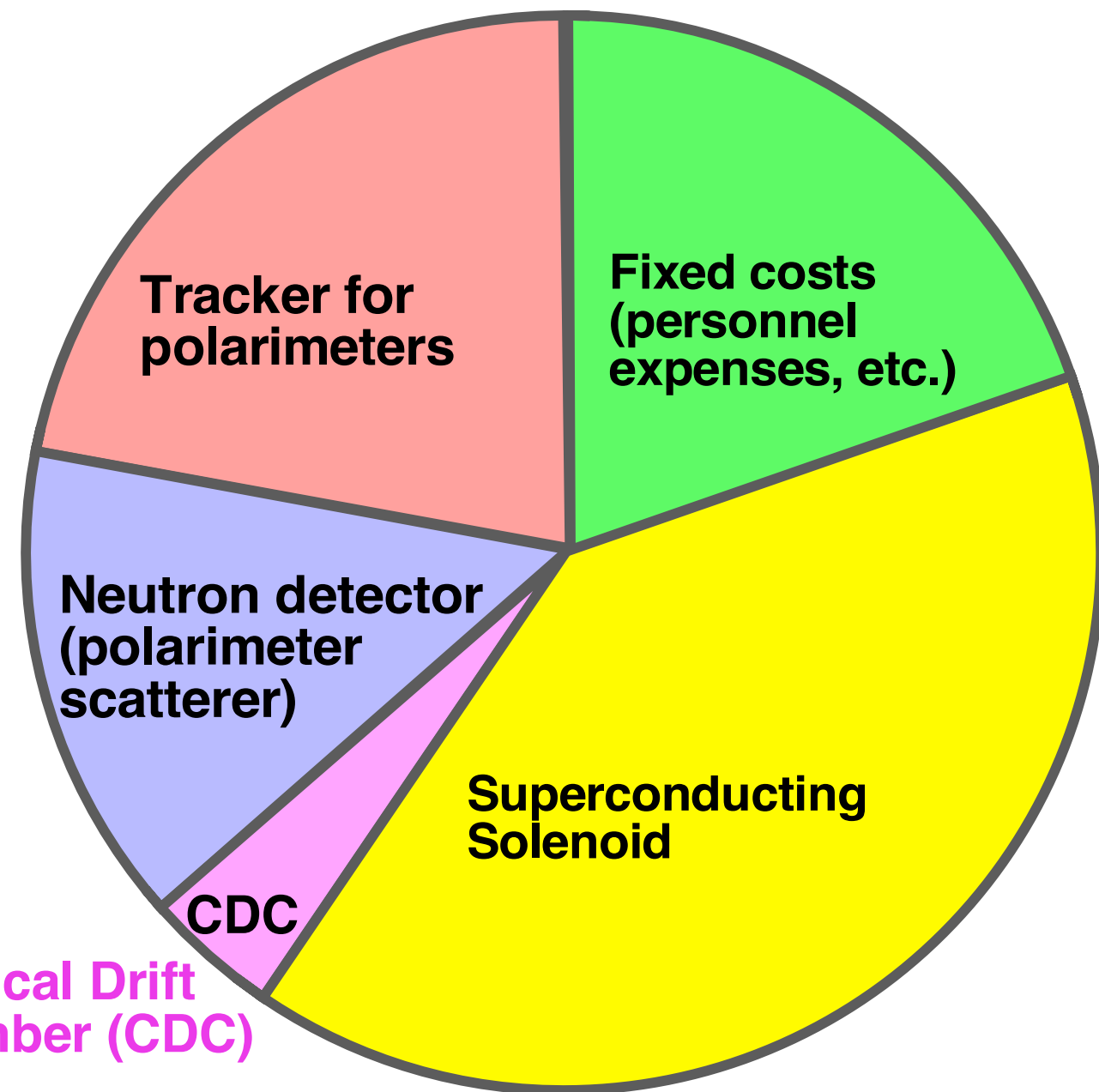

Allocated Budget

Approximately 500 million yen per lap.

Budget Profile and Objective of the Project

予算の現状分析と
今後の研究計画

Budget profile

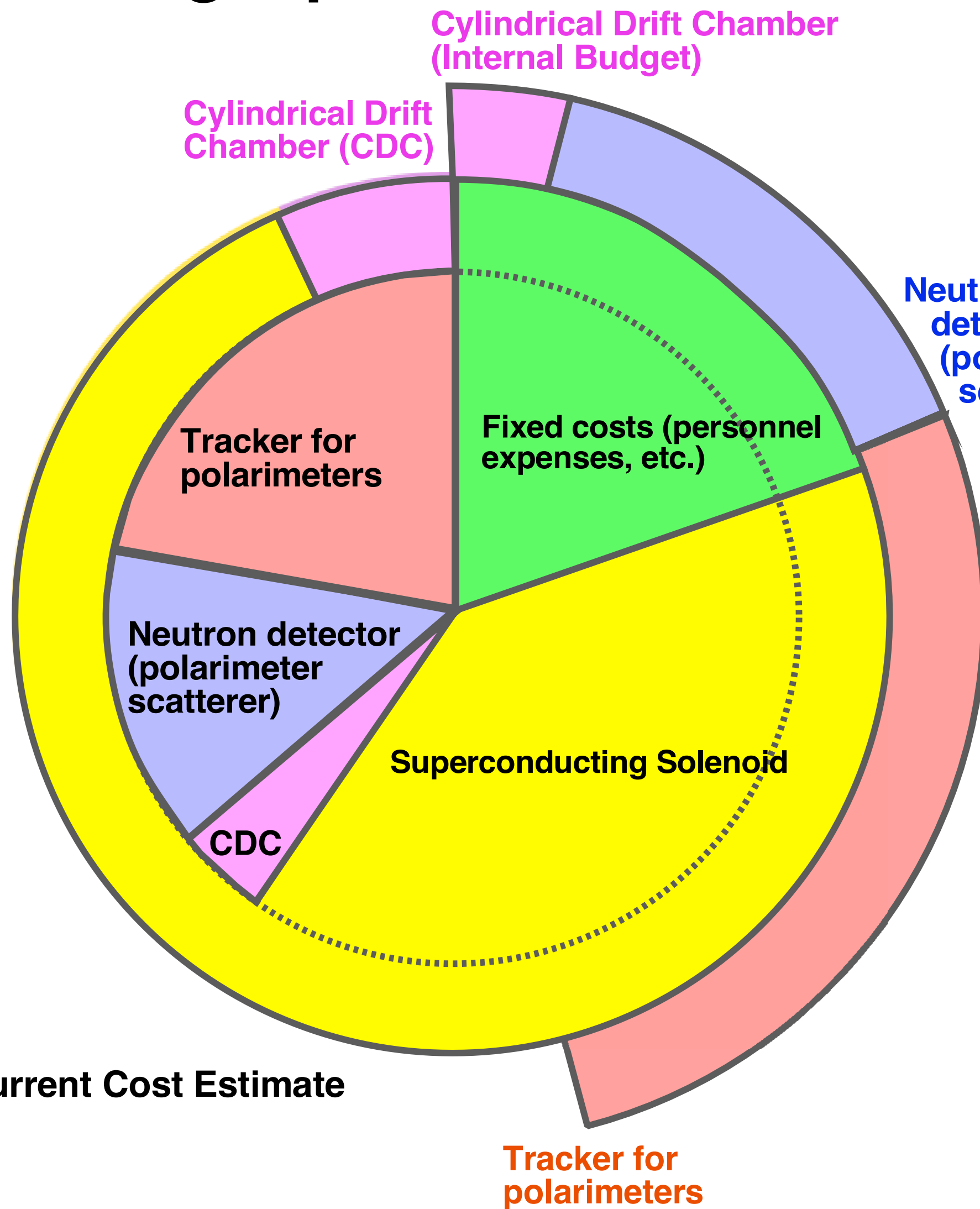

The rise in prices and transportation costs linked to the COVID-19 pandemic, the conflict in Ukraine, and rapid exchange rate fluctuations.

Withdrawal of a Japanese company from bidding for superconducting wire materials just before the deadline.

Budget Profile and Objective of the Project

予算の現状分析と
今後の研究計画

Budget profile

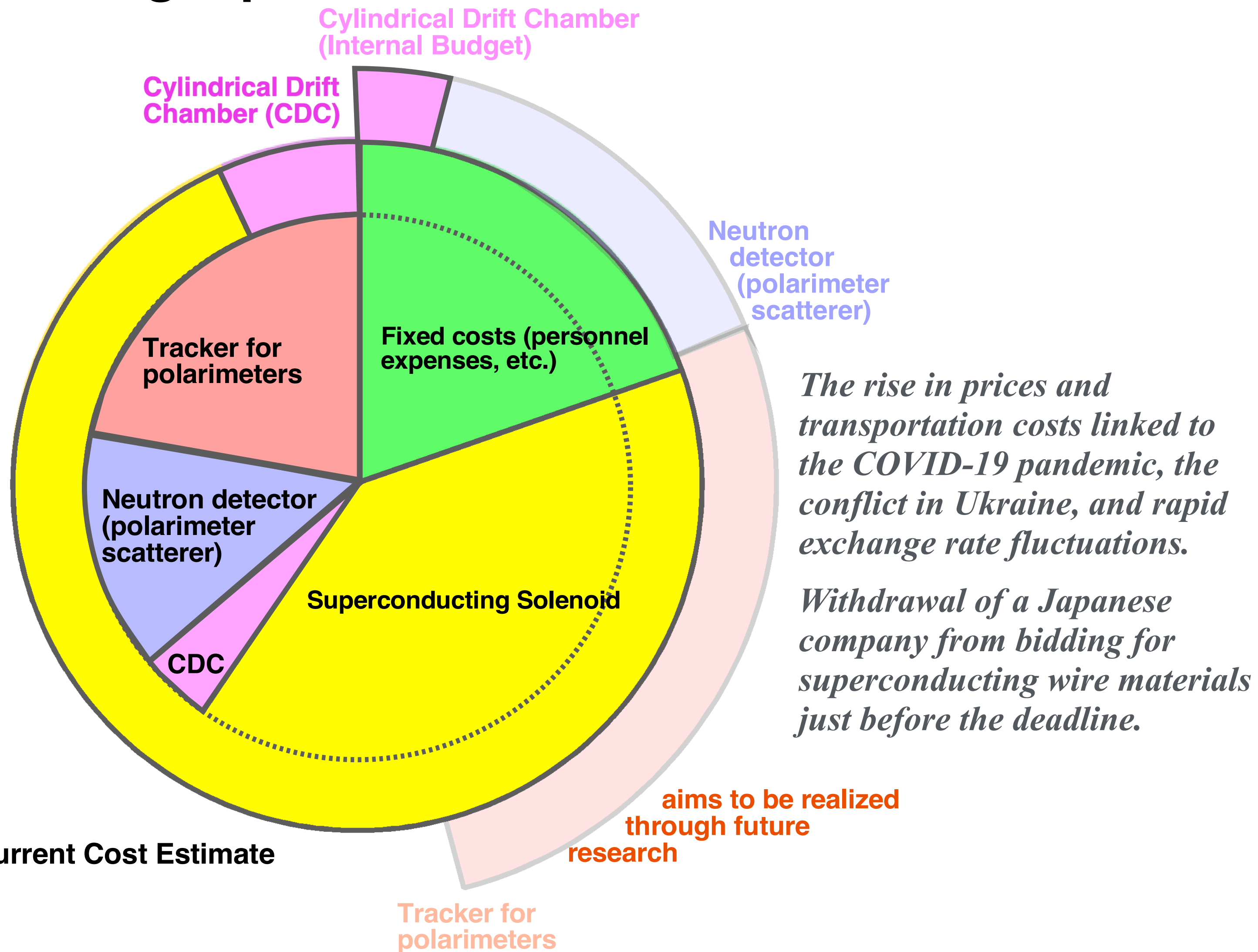

Budget Profile and Objective of the Project

予算の現状分析と
今後の研究計画

Budget profile

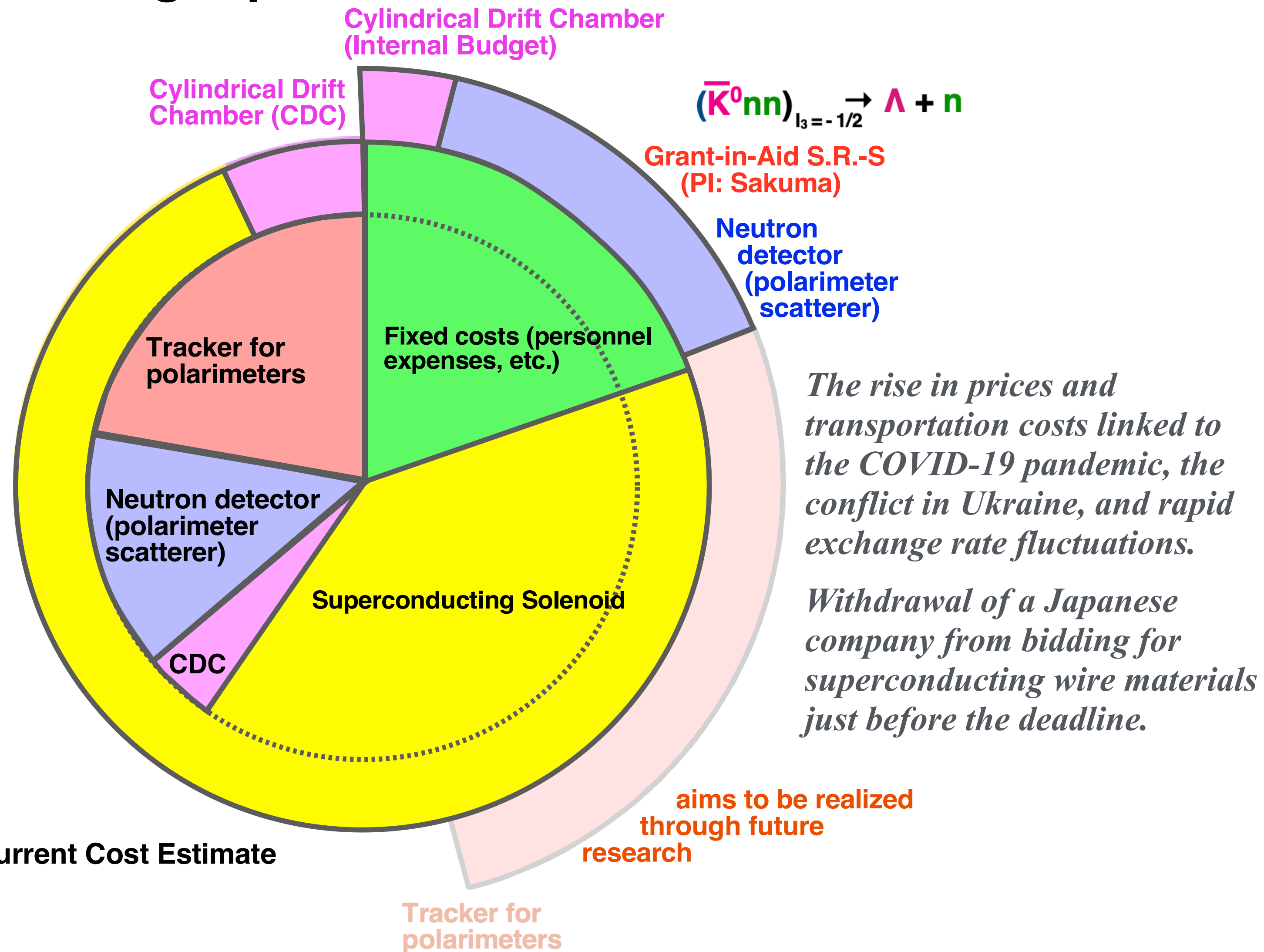

Budget Profile and Objective of the Project

予算の現状分析と
今後の研究計画

Budget profile

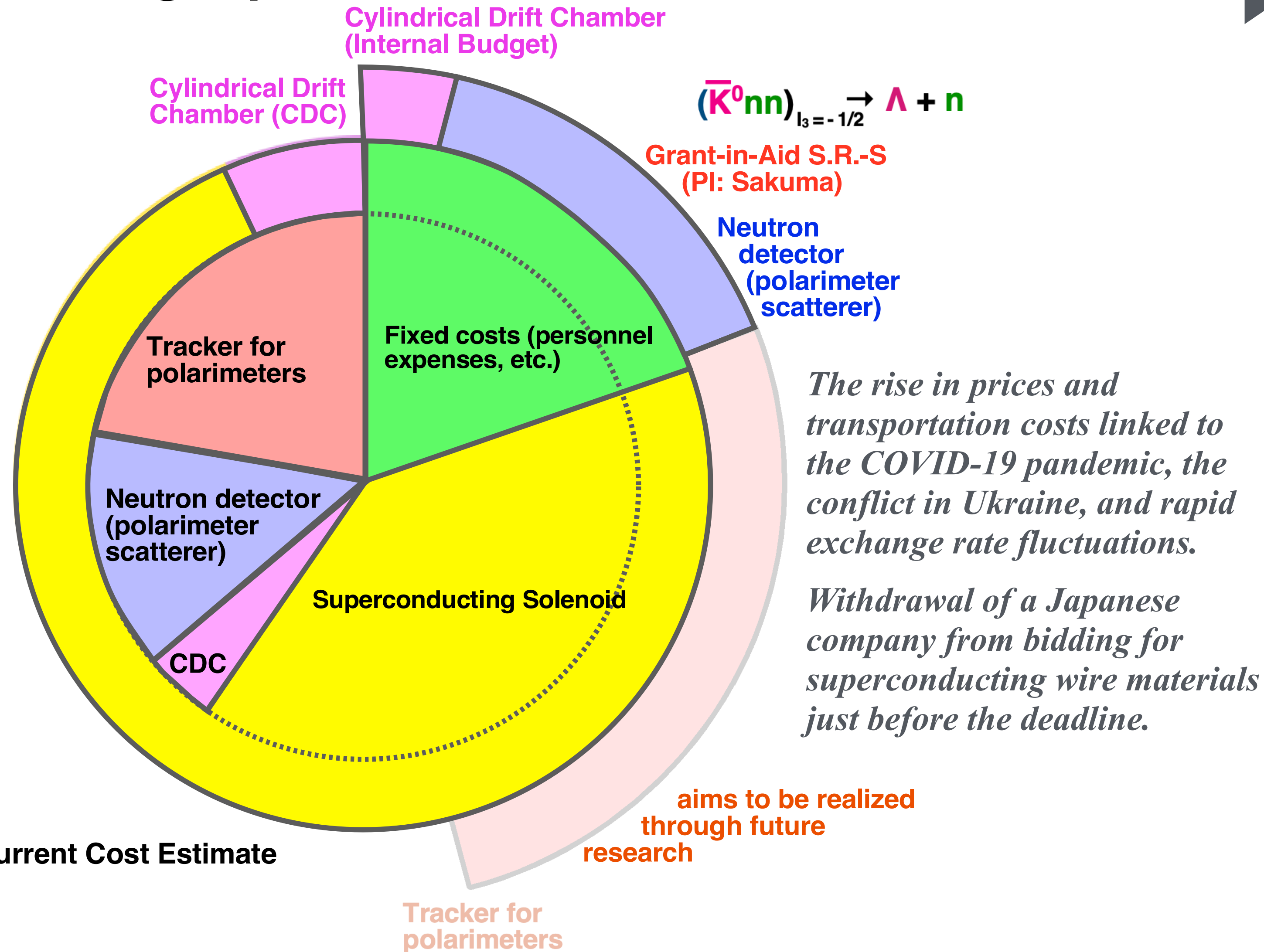

➔ Revising the Initial Objective

Initial Objective

- 1) Establish " $\bar{K}^0 nn$ " as a charge mirror state of " $K^- pp$ "
- 2) Identification of the spin and parity of " $K^- pp$ "
- 3) Developing structure and reaction calculations based on chiral dynamics by theoretically bridging QCD from the hadronic phase using lattice QCD for interactions.

revising 2)

2') Dedicative study on " $K^- ppn$ " via ^4He target

Concurrently with 1) and 3), by prioritizing research on the spatial size of the " $K^- ppn$ " ($I(J^P) = 0(1/2^-)$) state in 2').

The spin parity study on " $K^- pp$ " is crucial to completely remove concerns that " $K^- pp$ " could be an exotic composite state of " $\Sigma(1385)N$ " (or " $\Sigma(1385)NN$ " for " $K^- ppn$ "), and is essential for establishing it as a genuine K mesonic nuclear state.